

IP Paging Horn for SIP Endpoint Paging or Multicast Paging / Background Music, and Making Standard or Emergency SIP Calls

The **300TB-IP** Paging Horn with Talk-Back can be used for: standard one-way SIP endpoint paging, two-way conversations via SIP endpoint paging, one-way multicast paging, and making standard or emergency two-way SIP calls initiated from the optional auxiliary switch input. The microphone enables talk-back and also monitors room noise to automatically increase the speaker volume when necessary.

An optional auxiliary switch input allows a hard wired button or switch to initiate a SIP call. The button can be mounted on the wall or concealed under a desk, etc. A momentary button press will initiate a standard call, while holding the button for 3 or more seconds will initiate an emergency call.

The **300TB-IP** features a high efficiency 6 Watt class D amplifier capable of driving the horn at up to 113 dB SPL at 1 meter.

The **300TB-IP-EWP** shares all of the features of the **300TB-IP** in addition to Enhanced Weather Protection (EWP) for outdoor installations where the unit is exposed to precipitation or condensation. EWP products are designed to meet IP66 standards. For more information on EWP, see **DOD 859**.

⚠ Installation requires a Network Administrator / IT Technician



Features

- Large 10-inch diameter horn
- Fully adjustable mounting hardware included
- Quick and easy installation
- SIP compliant, see page two for more information
- PoE powered (class 3, <13 Watts)
- Paging prioritization
- Plays audio from standard multicast sources
- SIP endpoint or multicast group member
- Red call status LED indicator
- Automatic Noise Canceling (ANC) feature for operation in noisy environments
- Model **300TB-IP-EWP** comes with Enhanced Weather Protection (EWP), and is designed to meet IP66 Ingress Protection Rating when mounted with horn pointing downward at least 45 degrees from horizontal. For more info on Enhanced Weather Protection (EWP), see **DOD 859**.
- Proprietary VOX switching eliminates the need for "Push to Talk" mode
- Selectable auto-answer feature for monitoring
- Compatible with Polycom multicast paging
- Built-in high-efficiency 6 Watt class D amplifier
- SIP/Multicast: SIP page, SIP page and zoned multicast receive
- Support for access code to prevent unwanted SIP calls
- Hangs up on: busy signal, time-out, or touch tone command
- Network remote speaker volume control
- Automatic Gain Control (AGC) to automatically increase ring volume to compensate for ambient noise
- Diagnostics for testing microphone and horn driver
- Programmable pre-page alert tone

Applications

- Amplified SIP endpoint or multicast IP paging for: Schools, Hospitals, Retail Stores, Office Spaces, etc.
- Provide background music and sound masking
- Make standard and/or emergency SIP phone calls via handsfree talk-back speaker
- Background music and emergency calls for: commercial buildings, distribution centers, service/shop areas, gas stations, indoor/outdoor recreation and sports facilities, transport terminals, etc.

Information: 715-386-8861
www.VikingElectronics.com

Specifications

Power: PoE class 3 (<13 Watts)
Dimensions: 10.0" (23.4 cm) diameter, 11.5" (29.2 cm) long
Shipping Weight: 4.1 lbs (1.86 kg)
Operating Temperature: -40° F to 140° F (-40° C to 60° C)
Humidity - Standard Product: 5% to 95% non-condensing
Humidity - EWP Product: Up to 100%
SIP Audio Codecs: G711u, G722 and G711a
Multicast Audio Codecs: G711u and G722
Network Compliance: IEEE 802.3 af PoE, SIP 2.0 RFC3261, 100BASE-TX with auto cross-over
Regulatory Compliance: CE, FCC Part 15 and Canada ICES-003 Class A
Maximum Output Level: 113 dB SPL @ 1M
Amplifier: 6 Watt class D
Connections: (1) RJ45 10/100 Base-T, (2) butt connectors

VoIP SIP System Compatibility

For compatibility and vendor specific detailed configuration instructions, see the **Viking VoIP SIP System Compatibility List**, DOD 944. To open and download this PDF file:

Scan the QR code below to open and download the **Viking VoIP SIP System Compatibility List**



- OR -

1. Go to **www.vikingelectronics.com** and enter **944** in the search box
2. Click **Application Note (DOD 944)** to open and download the PDF

Important: Exclusion from this list means only that compatibility has not been verified, ***it does not mean incompatibility.*** If you have questions, please call Viking Electronics at 715-386-8861.

Definitions

Client: A computer or device that makes use of a server. As an example, the client might request a particular file from the server.

DHCP: Dynamic Host Configuration Protocol. In this procedure the network server or router takes note of a client's MAC address and assigns an IP address to allow the client to communicate with other devices on the network.

DNS Server: A DNS (Domain Name System) server translates domain names (ie: www.vikingelectronics.com) into an IP address.

Ethernet: Ethernet is the most commonly used LAN technology. An Ethernet Local Area Network typically uses twisted pair wires to achieve transmission speeds up to 1Gbps.

Host: A computer or device connected to a network.

Host Name: A host name is a label assigned to a device connected to a computer network that is used to identify the device in various forms of network communication.

Hosts File: A file stored in a computer that lists host names and their corresponding IP addresses with the purpose of mapping addresses to hosts or vice versa.

Internet: A worldwide system of computer networks running on IP protocol which can be accessed by individual computers or networks.

IP: Internet Protocol is the set of communications conventions that govern the way computers communicate on networks and on the Internet.

IP Address: This is the address that uniquely identifies a host on a network.

LAN: Local Area Network. A LAN is a network connecting computers and other devices within an office or building.

Lease: The amount of time a DHCP server reserves an address it has assigned. If the address isn't used by the host for a period of time, the lease can expire and the address can be assigned to another host.

MAC Address: MAC stands for Media Access Control. A MAC address, also called a hardware address or physical address, is a unique address assigned to a device at the factory. It resides in the device's memory and is used by routers to send network traffic to the correct IP address. You can find the MAC address of your **300TB-IP** speaker printed on a white label on the side of the chassis (see page 4).

Router: A device that forwards data from one network to another. In order to send information to the right location, routers look at IP Address, MAC Address and Subnet Mask.

RTP: Real-Time Transport Protocol is an Internet protocol standard that specifies a way for programs to manage the real-time transmission of multimedia data over either unicast or multicast network services.

Server: A computer or device that fulfills requests from a client. This could involve the server sending a particular file requested by the client.

Session Initiation Protocol (SIP): Is a signaling communications protocol, widely used for controlling multimedia communication sessions such as voice and video calls over Internet Protocol (IP) networks. The protocol defines the messages that are sent between endpoints, which govern establishment, termination and other essential elements of a call.

Static IP Address: A static IP Address has been assigned manually and is permanent until it is manually removed. It is not subject to the Lease limitations of a Dynamic IP Address assigned by the DHCP Server. The default static IP Address is: **192.168.154.1**

Subnet: A portion of a network that shares a common address component. On TCP/IP networks, subnets are defined as all devices whose IP addresses have the same prefix. For example, all devices with IP addresses that start with 100.100.100. would be part of the same subnet. Dividing a network into subnets is useful for both security and performance reasons. IP networks are divided using a subnet mask.

TCP/IP: Transmission Control Protocol/Internet Protocol is the suite of communications protocols used to connect hosts on the Internet. TCP/IP uses several protocols, the two main ones being TCP and IP. TCP/IP is built into the UNIX operating system and is used by the Internet, making it the de facto standard for transmitting data over networks.

TISP: Telephone Internet Service Provider

WAN: Wide Area Network. A WAN is a network comprising a large geographical area like a state or country. The largest WAN is the Internet.

Wireless Access Point (AP): A device that allows wireless devices to connect to a wired network using Wi-Fi, or related standards. The AP usually connects to a router (via a wired network) as a standalone device, but it can also be an integral component of the router itself.

Wireless Repeater (Wireless Range Extender): takes an existing signal from a wireless router or access point and rebroadcasts it to create a second network. When two or more hosts have to be connected with one another over the IEEE 802.11 protocol and the distance is too long for a direct connection to be established, a wireless repeater is used to bridge the gap.

Features Overview

Front View



Back View



Microphone:
Built-in omni-directional microphone for talk-back paging and automatic volume control.

Red Call/Status LED:
Flashes when unit is not registered, during manual reset and during dialing, lights steady when answered.

MAC Address Label:
The MAC address is a unique 12 digit number used by routers to send network traffic to the correct IP address.

Waterproof RJ45 Connector:
Protects the connections from outside elements. Open to expose Cat5 jack. Route Cat5 or greater wire through cover. Terminate wires per T568A or T568B, then tighten cover to create a seal around the Cat5 wire.

PoE LAN Port 10/100, PoE Class 3 (<13 Watts):
Connect to your LAN via RJ45 plug and CAT5 or greater twisted pair wire.

Optional Trigger Input / Reset Wires:
Open the waterproof RJ45 connector and remove black wires. Connect to an optional momentary switch (not included) to initiate outbound calls or answer inbound ringing SIP calls. Short wires during power up to reset security code or network parameters to factory default, see page 9 section E.

* Gel-filled butt connectors (included)

* **NOTE:** The gel-filled (water-tight) butt connectors are designed for insulation displacement on 19-26 gauge wire with a maximum insulation of 0.082 inches. Cut off bare wire ends prior to terminating.

Mounting

Step 1.	Attach the round mounting plate base to wall, ceiling, post, etc. with appropriate fasteners (not included) (Diagram A).
Step 2.	Loosely attach the two side collars to the paging horn using the Phillips head bolt, two washers, locking washer, and wing nut (Diagram B).
Step 3.	Slide this assembly onto the mounting plate base (Diagram C). Loosely secure with remaining carriage bolt, washer, locking washer, and wing nut (Diagram D).
Step 4.	With both wing nuts loose, rotate and angle the horn into position, then tighten both wing nuts to secure.

Diagram A

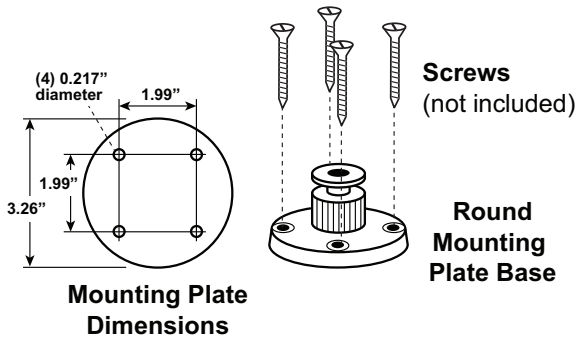

Diagram B

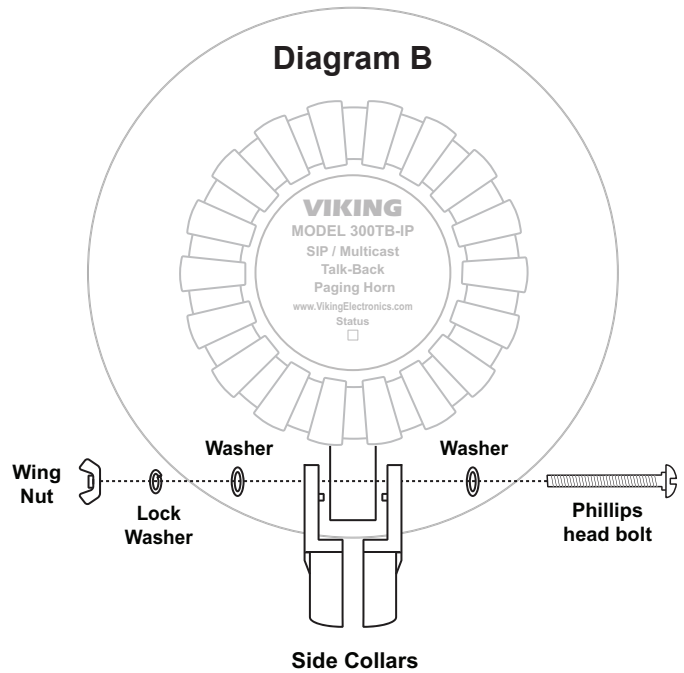

Diagram C

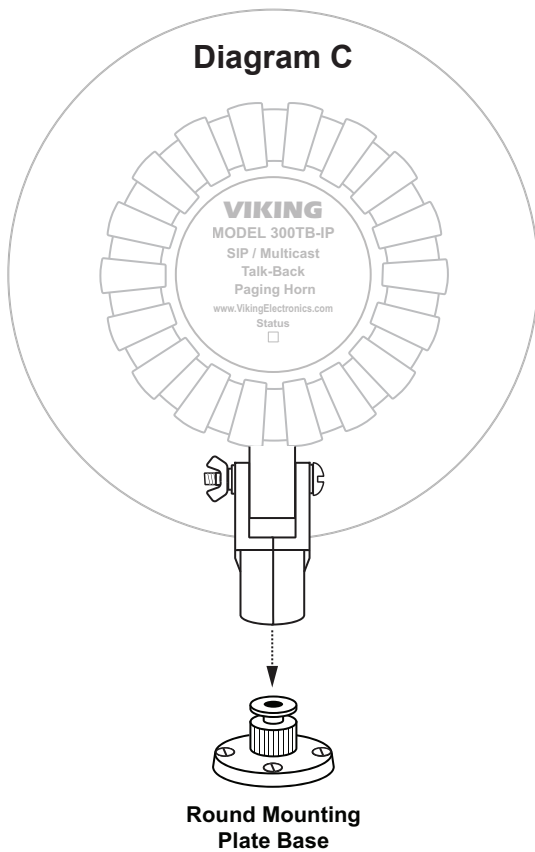
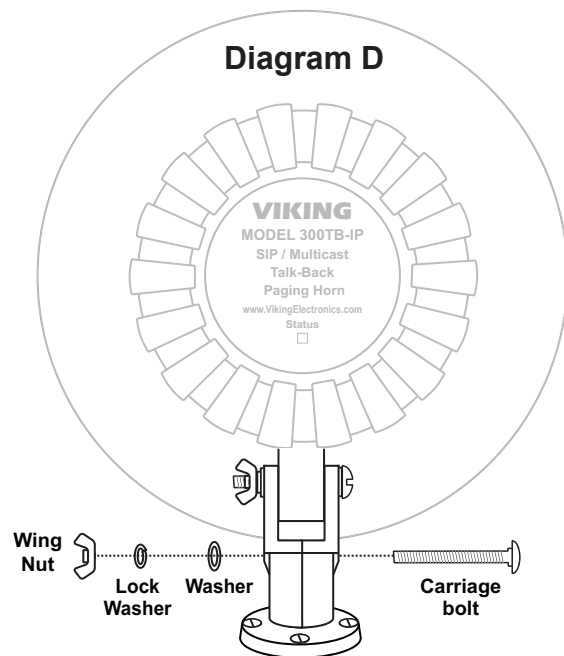
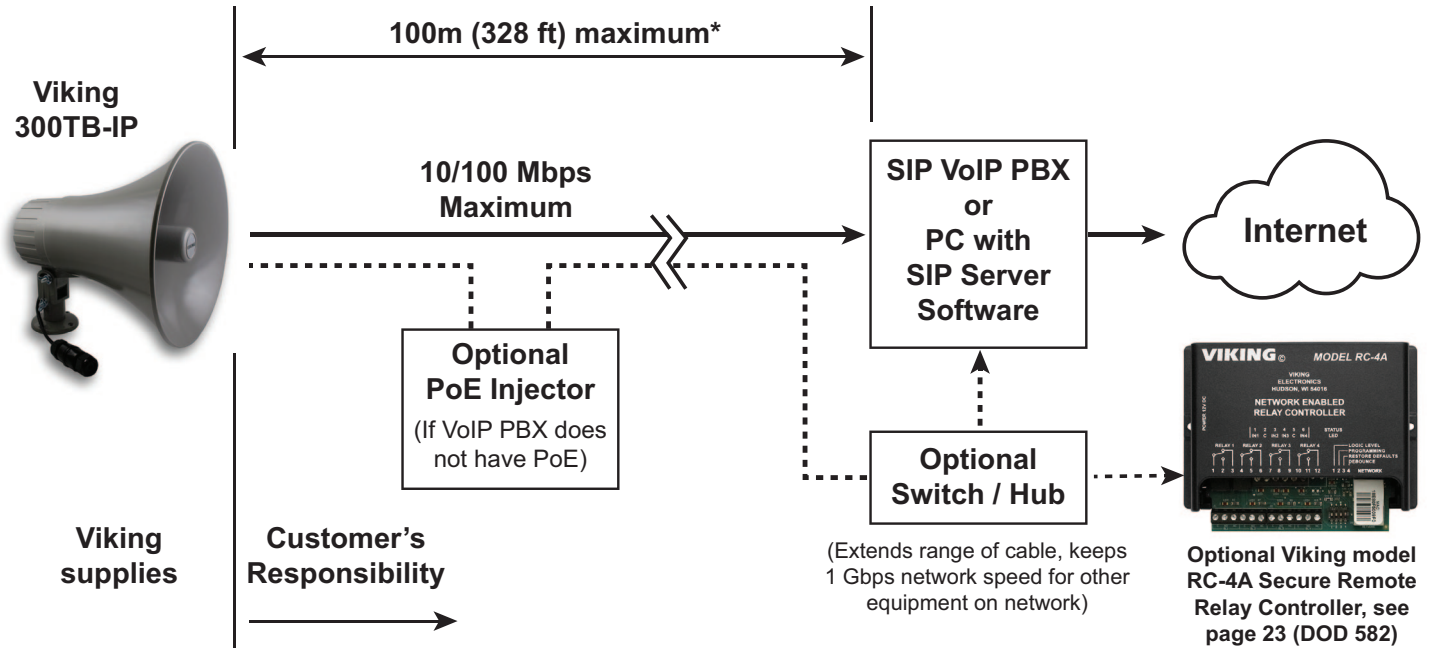

Diagram D



Typical Installation on SIP Based VoIP Phone System



* **Note:** A PoE extender can be used for an additional 100 meters per extender. For longer runs (up to 2 km / 1.2 miles) a ethernet to fiber media converter can be used.

PC Requirements

- IBM compatible personal computer with: Windows 7, 8, 10 or 11
- Adobe Acrobat Reader 8 or higher
- Available LAN with PoE (class 3, <13 Watts)
- Ethernet cable (CAT5 minimum)
- 1 MB minimum free hard drive space for installation
- 16MB of free physical RAM

PC Programming

Download and install the programming software

1. Go to www.vikingelectronics.com and enter **300TB-IP** in the search box
2. Click **300TB-IP** in the search results
3. Scroll down the page to Downloads, click **IP Programming Software**
4. Install the programming software by saving or opening the file and then clicking on **setup Viking IP Programming.exe**
5. Follow the prompts on your screen to complete software installation
6. To start the Viking IP Programming application, click on the Viking IP Programming icon on your desk top. The main screen will appear, allowing the user to program any **300TB-IP** connected to that LAN.

Note: PC must be connected to the same LAN as the **300TB-IP**.

A. Connect / Disconnect

Open the “Viking IP Programming” software on the PC and the start screen shown below will appear. Any Viking IP speakers that are connected to the network will appear on the list. Simply select the **300TB-IP** on the list and click on the “Connect” button at the bottom or double click the selected speaker. If no username and password have been programmed and the security code of the selected unit is still set to default (845464), the PC software will not require entering a username, password or security code to connect to the **300TB-IP**. If the **300TB-IP** has been programmed with a username and password, a pop up window will ask for the username followed by the password. If the unit’s security code has been changed from “845464”, it will then prompt for the correct security code. **300TB-IP**’s have a default name of “VIKING_MK64_Vik02”, so if many **300TB-IP**’s are connected to the same network and all have the default name, MAC addresses must be used to identify each **300TB-IP**.

When finished programming, click the “Disconnect” button at the bottom. Closing the program will also automatically disconnect the unit.

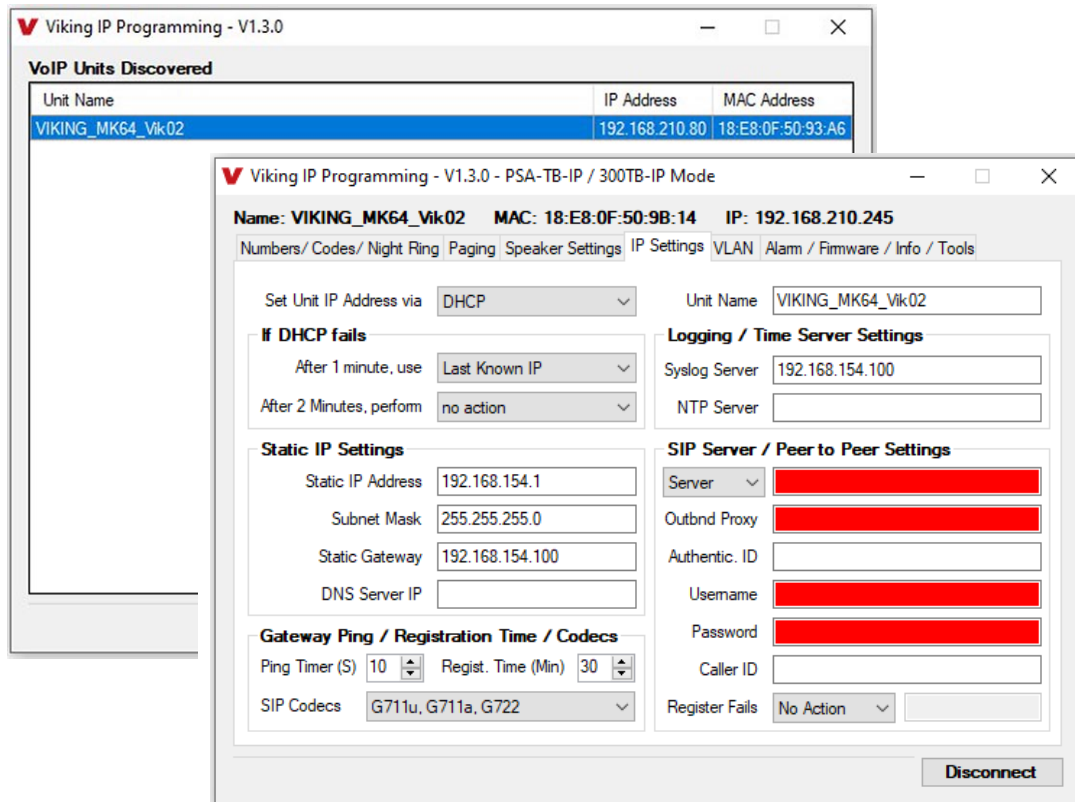

B. Configuring the 300TB-IP Network Settings

Step 1.	Open the “Viking IP Programming” software on a windows PC that is connected to the same LAN as the 300TB-IP speaker to be programmed.
Step 2.	The window in the upper left corner of the menu will show you each 300TB-IP speaker that is connected to that LAN. Select the unit with the same MAC address shown on the label located next to the Ethernet connector on the 300TB-IP speaker.
Step 3.	Click on the “connect” button. A default 300TB-IP has no username or password programmed, the security code is set to “845464” and when configured this way, you are instantly connected to the 300TB-IP . If the 300TB-IP has been programmed with a username and password, a pop up window will ask for the username followed by the password. If the unit’s security code has been changed from “845464”, it will then prompt for the correct security code, then click “retry”.
Step 4.	The program will then read and display the 300TB-IP speaker’s IP and programming settings.
Step 5.	Click on the “IP Settings” tab.
Step 6.	Select the appropriate value Static IP Settings or DHCP for “Set Unit IP Address via”. Note: Changing the IP address will cause you to have to reconnect to the unit. Enter the values for the fields in “if DHCP fails” or “Static IP Settings” as needed.
Step 7.	Set the “Unit Name”, “Logging / Time Server Settings” as needed.
Step 8.	Select Peer-Peer in the “SIP Server / Peer to Peer Settings” to use the unit in Peer to Peer mode or for Multicast paging only. Select Server to register with a SIP registrar server and fill in the “Outbnd Proxy” (SIP Outbound Proxy Server Address, “ip:port”), “Authentic. ID” (SIP Authentication ID), “Username” (SIP Username, <string>), “Password” (SIP Password), and “Caller ID” (SIP Caller ID) with values from your VoIP provider. Required fields will be red when the unit is not registered.

Viking IP Programming - V1.3.0 - PSA-TB-IP / 300TB-IP Mode

Name: VIKING_MK64_Vik02 MAC: 18:E8:0F:50:9B:14 IP: 192.168.210.245

Numbers/ Codes/ Night Ring | Paging | Speaker Settings | IP Settings | **VLAN** | Alarm / Firmware / Info / Tools

Set Unit IP Address via Unit Name

If DHCP fails

After 1 minute, use

After 2 Minutes, perform

Static IP Settings

Static IP Address

Subnet Mask

Static Gateway

DNS Server IP

Logging / Time Server Settings

Syslog Server

NTP Server

SIP Server / Peer to Peer Settings

Server

Outbnd Proxy

Authentic. ID

Username

Password

Caller ID

Register Fails

Gateway Ping / Registration Time / Codecs

Ping Timer (S) Regist. Time (Min)

SIP Codecs

Disconnect

C. Configuring 300TB-IP VLAN Settings

Step 1.	Click on the "VLAN" tab.
Step 2.	Disable or enable VLAN tagging by setting the value of "VLAN Tagging".
Step 3.	Set the VLAN tag ID by selecting an integer (1 to PSA-94) in "ID for all packets".
Step 4.	Set the Priority Code Point (PCP) value for all not SIP and RTP packets in the "PCP for all packets" input (0 is default, priorities are from low to high: 0, 1, 2, 3, 4, 5, 6, 7). Set the "PCP for SIP packets" (3 is default). Set the "PCP for RTP packets" (5 is default).

Viking IP Programming - V1.3.0 - PSA-TB-IP / 300TB-IP Mode

Name: VIKING_MK64_Vik02 MAC: 18:E8:0F:50:9B:14 IP: 192.168.210.245

Numbers/ Codes/ Night Ring | Paging | Speaker Settings | IP Settings | **VLAN** | Alarm / Firmware / Info / Tools

VLAN Tagging

Please exercise caution when setting VLAN tags, as an incorrect setting can disable the ability to connect to the unit until it is manually reset to factory defaults.

VLAN Tagging

ID for all packets

PCP for all packets

PCP for SIP packets

PCP for RTP packets

Disconnect

D. Manually Resetting the Security Code to Enter Programming

Note: This procedure will not erase a username and password used to access the **300TB-IP** program mode. Only the security code is set to default.

Step 1.	Power down the 300TB-IP speaker by disconnecting the LAN Cable (RJ45 plug).
Step 2.	Provide a short across the “Trig In” wires, then reconnect the LAN Cable (RJ45 plug).
Step 3.	Keep the short across the “Trig In” wires until you hear a single beep, silence and then 2 beeps (approximately 11 seconds). Then remove the short across the “Trig In” wires. The Status LED will remain off for 5 seconds, light steady for 3 seconds, flash slowly for 3 seconds then fast flash, (after the 2 beeps), indicating when to remove the short across the “Trig In” wires.
Step 4.	The security code is now reset to 845464 (factory default).
Step 5.	You can now enter programming by following the steps in section A .

E. Manually Resetting All Network Parameters to Factory Default

Note: This procedure will erase a username and password that are used to access the **300TB-IP** program mode.

Step 1.	Power down the 300TB-IP speaker by disconnecting the LAN Cable (RJ45 plug).
Step 2.	Provide a short across the “Trig In” wires, then reconnect the LAN Cable (RJ45 plug).
Step 3.	Keep the short across the “Trig In” wires until you hear a single beep, silence and then 2 beeps (approximately 11 seconds). Continue with the short across the “Trig In” wires until you hear 4 more beeps (approximately 6 seconds later), then remove the short across the “Trig In” wires. The Status LED will remain off for 5 seconds, light steady for 3 seconds, flash slowly for 3 seconds (2 beeps) flash fast for 6 seconds, (4 beeps), then light steady indicating when to remove the short across the “Trig In” wires.
Step 4.	You can now enter programming by following the steps in section A .

Programming Features Index

DESCRIPTION	Section	Page
Connect / Disconnect	A	7
VLAN Settings	C	8
Unit Name	1	10
SIP Server	2	10
Peer to Peer Settings	3	11
Outbound Proxy	4	11
Authentication ID	5	11
Register Fails (Re-Resolve or Alternate Server)	6	11
Pre Page Tone	7	12
Multicast Page Type	8	12
Multicast Page Time Out (1 - 255 seconds, factory set to 180 seconds)	9	12
SIP Page / Call Priority VS Multicast	10	13
Multicast Paging (Standard or Polycom, factory set to Standard)	11	13
Multicast Paging Volume (0 - 19, factory set to 1)	12	14
Emergency Phone Number and Non-Emergency Phone Number	13	14
Security Code (factory set to 845464)	14	14
ID Number	15	14
Access Code (1 - 6 digits, blank = Disabled, factory set to 123456)	16	15
Night Ring Timed Operation	17	15
Time Zone Settings / Daylight Saving Time	18	15
External Relay (factory set to Disabled)	19	15
Ext Relay Mode (Door Strike, Outbound Call, Phone or Paging, Doorbell, Ring, Ring Flash, factory set to Door Strike)	20	16
Ext Relay Activation Command (1 or 2 digits, factory set to **) NOTE: Relay Mode must be set to Door Strike.	21	16

Programming Features Index

DESCRIPTION	Section	Page
Ext Relay Activation Time (0.5 - 99 seconds, factory set to 5 seconds)	22	16
Ext Relay Buzz Volume (1 - 3 or Disabled, factory set to 3)	23	16
Ext Relay Latch Commands (Enabled or Disabled, factory set to Enabled) NOTE: <i>Relay Mode must be set to Door Strike</i>	24	16
Panic Button mode (Enabled or Disabled, factory set to Disabled)	25	16
Speaker Mode (ON, OFF / Silent Monitor, or OFF until Answered, factory set to ON)	26	17
SIP Paging Volume (0 - 19, factory set to 1)	27	17
Ring Volume (0 - 19, factory set to 5)	28	17
Microphone Volume (0 - 9, 0 = Auto, factory set to 5)	29	17
Talk/Listen Delay (VOX) (0.1 - 0.9 seconds, factory set to 0.5 seconds)	30	17
In-Band Audio Call Progress (Enabled or Disabled, factory set to Enabled)	31	17
In-Band Audio Detect Sensitivity (1 - 9, 1 = minimum, 9 = maximum, factory set to 5, power cycle unit after setting)	32	17
Redial Count (1 - 9 or Disabled, factory set to Disabled)	33	17
SIP Page / Call Length Time Out (Disabled or 1 - 9 minutes, factory set to 3 minutes)	34	18
Inbound Call Mode (Disabled, Auto Answer, Auto Answer-Secure, Ring, or Ring with AGC, factory set to Auto Answer)	35	18
Ring Cadence (factory set to Normal Ring = 2 seconds ON, 4 seconds OFF)	36	18
Redial on Ring No Answer (Disabled or 1-9 rings, factory set to 7)	37	18
Redial on Busy (Disabled or Enabled, factory set to Enabled)	38	18
Mute Current / Next Alarm	39	19
Permanent Alarm Mute	40	19
Programming Username and Password	41	19
IP Firmware	42	19
Unit Firmware	43	20
Import / Export	44	20
Clear Speaker Settings	45	20
Clear IP Settings	46	20
Diagnostics (used to check microphone, speaker, and external relay operation)	47	20

Programming Features

1. Unit Name

Up to a 30 character unit name can be assigned to the **300TB-IP** being programmed.

2. SIP Server

Enter the IP address or URL of your SIP server or service provider in this field. The SIP server IP address is limited to 74 characters. **Note:** *If an alternate SIP server IP address is programmed, the IP address for the SIP server and alternate SIP server will be limited to 31 characters.* **Note:** *If outbound proxy is not required, enter the SIP server IP address into the Outbnd Proxy field.*

3. Peer to Peer Settings

When set to the Peer to Peer mode, a SIP server is not used. The **300TB-IP** will register to itself. Applications for the Peer to Peer mode are very limited, as the **300TB-IP** is only able to call other IP phones or SIP devices that are on the same LAN. The **40TB-IP** can not call analog extensions, digital phone extensions, telephone numbers that are outside the phone system or another handsfree Viking IP device in this mode (see note below). To use the unit in the Peer to Peer mode, change the drop-down in the “SIP Server / Peer to Peer Settings” from “Server” to “Peer to Peer”, a Username must be assigned (can be any alpha/numeric string up to 31 characters) and the unit should be programmed with a static IP address. Here is an example to show how the calling process works:

	300TB-IP	Destination IP Phone
IP Address	192.168.210.1	192.168.210.3
Extension Number	N/A	200
Username	Viking1	N/A

300TB-IP calling the IP phone – you populate the first phone number field with 200@192.168.210.3 (the extension number you are trying to call + @ + the IP address of the extension you are calling).

The IP phone calling the **300TB-IP** – a button on the IP phone is configured to dial Viking1@192.168.210.1 (the Username assigned in the **300TB-IP** + @ + the IP address of the **300TB-IP**).

- Notes:**
1. A Viking handsfree IP Device calling another Viking handsfree IP Device is not recommended.
 2. Peer to Peer mode does not affect multicast paging.

4. Outbound Proxy

If your SIP provider requires an outbound proxy IP address enter it in the “Outbound Proxy” field. If outbound proxy is not required enter the SIP server IP address into the “Outbound Proxy” field. **NOTE:** If not required, this field must match your SIP server IP address.

5. Authentication ID

If your SIP provider requires Authentication ID, enter it in the “Authentic. ID” field. If Authentication ID is not required, leave this field blank.

6. Register Fails (Re-Resolve or Alternate Server)

When registered to a SIP server in the event that registration is lost you can program the unit to re-resolve using the current SIP server IP address or route pages through an alternate SIP server. With Alternate Server selected enter the IP address of the alternate SIP server in the field next to the Register Fails drop down box. **Note:** With an alternate SIP server IP address programmed, the IP address for the SIP server and alternate SIP server will be limited to 31 characters.

Standard

The screenshot shows the 'Viking IP Programming - V1.3.0 - PSA-TB-IP / 300TB-IP Mode' window. At the top, it displays the device name 'VIKING_MK64_Vik02', MAC address '18:E8:0F:50:9B:14', and IP address '192.168.210.245'. Below this are navigation tabs: 'Numbers/Codes/ Night Ring', 'Paging', 'Speaker Settings', 'IP Settings', 'VLAN', 'Alarm / Firmware / Info / Tools'. The 'Paging' tab is active, showing settings for 'Pre Page Tone' (Enabled), 'Multicast Page Type' (Standard), and 'Multicast Page Length Time Out' (180 sec). A section titled 'SIP Page / Call Priority vs Multicast' contains two dropdown menus: 'Incoming SIP call priority' and 'Outgoing SIP call priority', both set to 'Above Group 0 (Highest)'. The 'Paging Sources (Multicast IP and Port) - Volume Level - Timeout Enable/Disable' section contains a table with 10 rows (0-9). Each row has a text input field for IP, a dropdown for port (all set to 1), a 'Vol' dropdown (all set to 1), and a 'TO' checkbox (all checked). A 'Disconnect' button is located at the bottom right of the window.

7. Pre Page Tone

When enabled, a short beep will be heard prior to SIP or Standard Multicast paging audio. The volume of the Pre Page Alert Tone will match the volume setting of the SIP or Standard Multicast page. **Factory Setting:** Enabled

8. Multicast Page Type

Select Standard or Polycom as the source of multicast paging. If Polycom is selected as the source, the screen will change to show its options (see below). For Details see #11 on Page 13.

Factory Setting: Standard (shown on Page 11)

9. Multicast Page Timeout

The Multicast Page Length Timeout can be programmed from 1 - 255 seconds in one second increments. The Time Out can be disabled, allowing any length of page or continuous background music. Only one timeout time can be programmed for all multicast paging groups. When using standard Multicast Paging, a timeout checkbox can be selected for each paging group. When using Polycom Multicast Paging, the timeout checkbox enables the timeout globally on groups 1 through 24. There is no timeout for a page to the emergency group 25.

Factory Setting: 180 seconds

Polycom Multicast Paging Tab

The screenshot shows the 'Paging' tab of the 'Viking IP Programming - V1.3.0 - PSA-TB-IP / 300TB-IP Mode' window. The device name is 'VIKING_MK64_Vik02', MAC is '18:E8:0F:50:9B:14', and IP is '192.168.210.245'. The 'Pre Page Tone' is set to 'Enabled'. The 'Multicast Page Type' is set to 'Polycom'. The 'Multicast Page Length Time Out' is set to '180 sec'. Under the 'SIP Page / Call Priority vs Multicast' section, 'SIP In Above' and 'SIP Out Above' are both set to 'Polycom'. The 'Polycom Paging Source and Group Subscriptions' section includes fields for 'IP Address', 'Port' (set to 1), 'Volume' (set to 1), and a checked 'Timeout' checkbox. Below these fields, a grid of checkboxes allows selecting groups 01 through 24 for subscription, with all checkboxes currently checked.

Group	Subscription
Grp 01	<input checked="" type="checkbox"/>
Grp 02	<input checked="" type="checkbox"/>
Grp 03	<input checked="" type="checkbox"/>
Grp 04	<input checked="" type="checkbox"/>
Grp 05	<input checked="" type="checkbox"/>
Grp 06	<input checked="" type="checkbox"/>
Grp 07	<input checked="" type="checkbox"/>
Grp 08	<input checked="" type="checkbox"/>
Grp 09	<input checked="" type="checkbox"/>
Grp 10	<input checked="" type="checkbox"/>
Grp 11	<input checked="" type="checkbox"/>
Grp 12	<input checked="" type="checkbox"/>
Grp 13	<input checked="" type="checkbox"/>
Grp 14	<input checked="" type="checkbox"/>
Grp 15	<input checked="" type="checkbox"/>
Grp 16	<input checked="" type="checkbox"/>
Grp 17	<input checked="" type="checkbox"/>
Grp 18	<input checked="" type="checkbox"/>
Grp 19	<input checked="" type="checkbox"/>
Grp 20	<input checked="" type="checkbox"/>
Grp 21	<input checked="" type="checkbox"/>
Grp 22	<input checked="" type="checkbox"/>
Grp 23	<input checked="" type="checkbox"/>
Grp 24	<input checked="" type="checkbox"/>

10. SIP Page / Call Priority vs Multicast

Incoming and outgoing non-emergency SIP call audio streams can be programmed to have priority over any of the 10 standard multicast paging groups. Use the “SIP In Above” and “SIP Out Above” drop down menus to select which multicast groups you want SIP calls to have priority over. “SIP In Above” is to set the priority of incoming SIP pages and “SIP Out Above” is to set the priority of outgoing non-emergency SIP calls. Regardless of the priorities selected, outgoing SIP emergency calls have the highest priority and will interrupt any multicast source.

Factory Setting for both: 0 (SIP is highest priority)

When Polycom is selected as the Multicast Page Type, the “SIP In Above” and “SIP Out Above” priorities can be set to “Poly” or “None”. See the following tables for the order of priorities with each setting. As shown, outgoing SIP emergency calls have the highest priority and Polycom Group 25 multicast has the second highest priority. The priority options allow you to determine the priorities for Polycom Groups 1 through 24 multicast signals, SIP paging and non-emergency outbound SIP calls. **Factory Setting for both:** Poly

Paging Priorities (SIP In Above and SIP Out Above both set to “Poly”)	Paging Priorities (SIP In Above and SIP Out Above both set to “None”)
Emergency Outbound SIP Calls	Emergency Outbound SIP Calls
Polycom Group 25	Polycom Group 25
Non-emergency Outbound SIP Calls and SIP paging	Polycom Groups 1-24
Polycom Groups 1-24	Non-emergency Outbound SIP Calls and SIP paging

Paging Priorities (SIP In Above set to “None” and SIP Out Above set to “Poly”)	Paging Priorities (SIP In Above set to “Poly” and SIP Out Above set to “None”)
Emergency Outbound SIP Calls	Emergency Outbound SIP Calls
Polycom Group 25	Polycom Group 25
Non-emergency Outbound SIP Calls	SIP Paging
Polycom Groups 1-24	Polycom Groups 1-24
SIP Paging	Non-emergency Outbound SIP Calls

11. Standard or Polycom Multicast Paging

Standard

When using standard Multicast Paging, up to 10 multicast paging groups can be programmed into each **300TB-IP** speaker. Each multicast group is defined by a multicast address and port number. Each multicast group is assigned a priority, allowing simultaneously arriving pages to be serviced based on importance. A timeout check box can be selected for each paging group. See Multicast Page Timeout under Paging Settings to adjust the timeout from 1 - 255 seconds. Only one timeout time can be programmed for all groups. The volume for each multicast group can be programmed separately.

Assigning Priority to standard Multicast Paging

The **300TB-IP** will prioritize simultaneous audio streams according to their priority in the Paging Sources list. Group 0 will have the highest priority while group 9 will have the lowest priority. Group 9 is useful for a low priority stream such as background music. Group 0 is useful for high priority streams such as emergency messages.

The multicast paging groups can also be used for up to ten different paging zones for receiving audio streams. A paging zone can consist of one or many **300TB-IP** multicast speakers. There is no limit to how many speakers can be in a given paging zone. Each multicast group is defined by a multicast address and port number. Each multicast group is assigned a priority, allowing simultaneously arriving pages to be serviced based on importance.

Polycom

Polycom IP phones send multicast audio to a specific IP address and port. A total of 25 groups can be used, with group 25 generally reserved for an emergency broadcast. Set the Multicast Page Type to “Polycom”. The Viking IP programming page will then show “Polycom Paging Source and Group Subscriptions”. Polycom phones will default to IP address 224.0.1.116 and port 5001 for multicast. Under “Polycom Paging Source and Group Subscriptions”, enter the IP address and port you chose in the Polycom IP phone as “Multicast IP address” and “port” (Paging/PTT Configuration page). Select the paging groups the **300TB-IP** should subscribe to. Any multicast audio sent to the correct IP address, port number and a subscribed group will be heard from the Speaker terminals. Group 1 is the lowest priority and group 25 is the highest. The Volume and Timeout can be selected globally, although the timeout does not affect group 25. **Factory Setting:** all Groups selected

12. Multicast Paging Volume

The volume of each individual standard multicast page can be adjusted from 0 - 19. When polycom paging is used, the paging volume is set globally for all 25 groups. **Factory Setting:** 1

The screenshot shows the 'Viking IP Programming - V1.3.0 - PSA-TB-IP / 300TB-IP Mode' window. The device information is: Name: VIKING_MK64_Vik02, MAC: 18:E8:0F:50:9B:14, IP: 192.168.210.245. The 'Paging' tab is selected. The interface is divided into four main sections: 1. 'Emergency and Non-Emergency Numbers' with fields for 'Emergency' and 'Non-Emerg.' and explanatory text. 2. 'Night Ring Timed Operation' with a 'Night Ring Time Control' dropdown set to 'Disabled', 'Night Ring Start Time' set to 17:00, 'Night Ring Stop Time' set to 8:00, and 'Time Control Active Days' checkboxes for Su, Mo, Tu, We, Th, Fr, Sa. 3. 'Speaker Codes' with fields for 'Security Code (6 digits)' (845464), 'ID Number (0-6 digits)', and 'Access Code (0-6 digits)' (123456). 4. 'Time Zone Settings' with 'Time Zone' set to '(UTC - 06:00) CST', 'Daylight Saving Time' set to 'Disabled', 'DST Begins' set to '2nd Sunday of March', and 'DST Ends' set to '1st Sunday of November'. A 'Disconnect' button is located at the bottom right.

13. Emergency Phone Number and Non-Emergency Phone Number

Note: Up to 125 digits can be stored in the emergency phone number and non-emergency phone number positions. The phone number called when a hard wired switch is pressed depends on the programming of the “Panic Button Mode” (“Speaker Settings” tab, See Programming section 25.)

Emergency Phone Number

The number programmed in the “Emergency” field is the telephone or extension number that is dialed for an emergency call. The **300TB-IP** will also detect busy and redial the number with “Dial Next Number on Busy” Enabled.

Non-Emergency Number

The number programmed in the “Non-Emerg” field is the telephone or extension number that is dialed for a non-emergency call. The **300TB-IP** will also detect busy and redial the number with “Dial Next Number on Busy” Enabled.

14. Security Code

The security code allows the user/installer to program the **300TB-IP** with a PC and the required ‘Viking IP Programming’ software. If the security code is left as default, the PC software won’t require entering a security code when connecting to the **300TB-IP**. It is recommended that the factory set security code be changed. The security code can be set back to default by holding the Reset button while the **300TB-IP** powers up. See section D on page 9 for details. It can also be defaulted by connecting to the unit with the IP Programming Software and clicking on the “Clear Speaker Settings” button on the “Alarm / Firmware” tab. **Factory Setting:** 845464

NOTE: The security code must be 6 digits and cannot include a * or #.

15. ID Number:

The ID Number (1 - 6 digits) is used by emergency personnel to identify the location of the caller and is given out when the receiving party presses a *. This ID number is transmitted as In-Band DTMF. This can be cleared out by leaving the field blank. **Factory Setting:** (blank)

16. Access Code

The Access Code is primarily used along with the “Auto Answer Secure” Inbound Call Mode to force inbound SIP page callers to dial the Access Code before they can make a SIP page. The Access Code also comes into play when using the relay of the **300TB-IP** to open a door or gate. When you call the **300TB-IP** and the unit automatically answers the call (see Programming section 38), you must dial the Access Code before you are allowed to operate the door strike relays, as extra security on inbound calls. Once a tenant has entered the correct Access Code, 2 beeps are heard and the user can now enter any “Operation Commands” (see Operation section D). The Access Code can be disabled if this basic security is not required. **Factory Setting:** 123456

Note: The Access Code can be 1 - 6 digits in length and cannot include a * or # or match the numbers used for the Security Code.

17. Night Ring Timed Operation

When Night Ring Timed Operation is enabled, if a SIP call is received during the programmed Start and Stop times, the **300TB-IP** will output loud ring on the “Speaker Out” terminals. This is selectable for each day of the week. When outside of the Night Ring timing window, the Inbound Call Mode setting will determine how SIP calls are handled. **NOTE:** For timed Night Ringing the unit must be synced with a time server. If the Night Ringing feature is enabled in the software you will be asked to use Viking Time Server when changes are applied. The address will be entered by the software automatically.

18. Time Zone Settings / Daylight Savings Time

When using the Night Ring Timed Operation the **300TB-IP** must be synced with the network time. Set the Time Zone Settings to match the settings on the network the unit is connected to for proper timed operation.

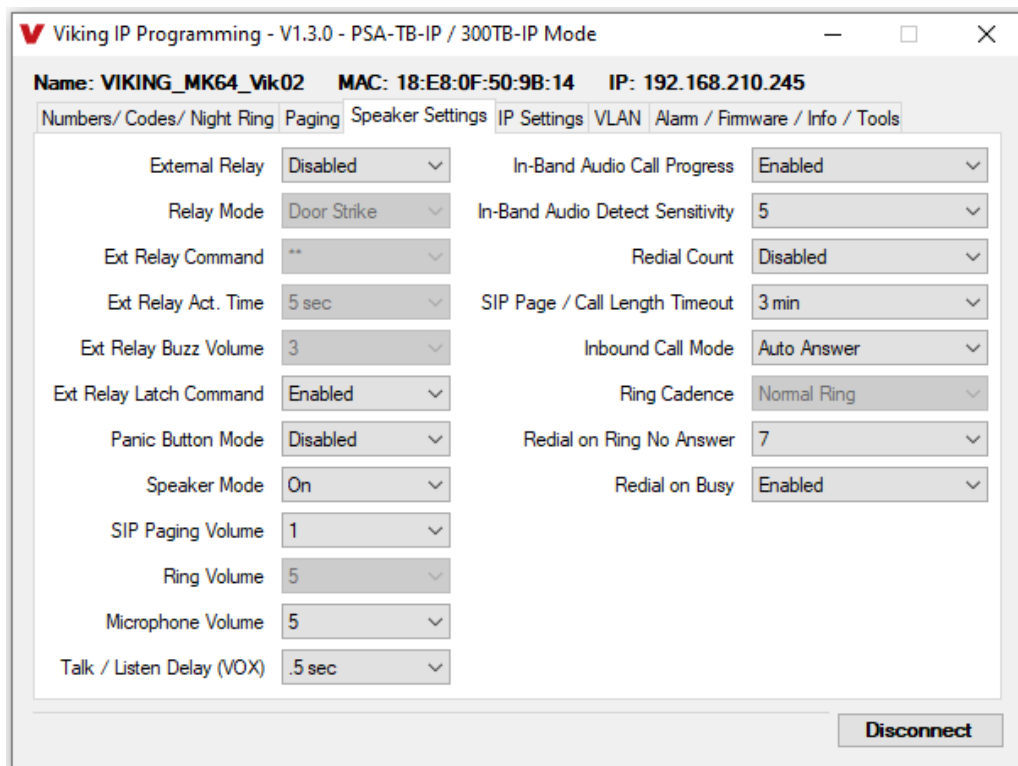

19. External Relay

A Viking remote model **RC-4A** relay controller can be used to activate up to four external relays (see page 23). With the external relay set to “EXT” the **300TB-IP** will activate an optional RC-4A relay controller.

Factory Setting: Disabled

20. Ext Relay Mode

Door Strike Mode: When programmed for Door Strike Mode the relay is intended for door strike, magnetic lock or gate control.

Outbound Call Mode: When programmed for Outbound Call Mode the relay will activate continuously for the duration of any outbound call from the speaker phone.

Phone / Paging Mode: When programmed for Phone/Paging Mode the relay will activate continuously for the duration of any SIP or multicast page or any inbound or outbound call to or from the speaker phone. This mode is useful for triggering paging amplifiers, etc.

Doorbell Mode: When programmed for Doorbell Mode the speaker phone will momentarily activate the relay for the preprogrammed relay activation time on any outbound call from the speaker phone. This mode is useful for activating a door chime, etc. When activating door chimes, a 0.5 - 1 second relay activation time is recommended.

Ring Mode: When programmed for Ring Mode the relay will continuously activate while the ringing extension is called. This mode is useful for activating a Viking model **SL-2** strobe light, etc.

Ring Flash Mode: When programmed for Ring Flash Mode the relay will momentarily turn on and off in a 400 ms on/off cadence while the ringing extension is called. This mode is useful for activating a Viking **LPL-1** Remote Visual Indicator, etc.

21. Ext Relay Activation Command

The one or two digit code stored in the Relay Activation Command is the touch tone command that the person being called must enter on their phone in order to momentarily activate the relay to control a door strike, magnetic lock, gate controller, or other device. The code can contain the characters 0-9, # or *. The code cannot match a relay latching command (*1, *0). The code must be entered while the remote phone is communicating with the speaker phone.

Factory Setting: **.

22. Ext Relay Activation Time

The value stored in the Relay Activation Time is the amount of time the relay will be energized after a correct momentary touch tone command is entered. This number can range from 0.5 - 99 seconds. This also affects timing in Doorbell Mode. **Factory Setting:** 5 seconds

23. Ext Relay Buzz Volume

The relay activation tone is a buzzing sound that is heard from the speaker when the door strike relay is activated. After the called party enters the correct relay activation command, the called party will hear 2 short confirmation beeps and the speaker will output a buzzing sound (relay activation tone) while the door strike relay is activated. The tone (buzz) length will match the relay activation time up to a maximum of 5 seconds. The tone (buzz) can be programmed to three different volume settings 1 = Low, 2 = Medium, 3 = High or it can be disabled. When disabled, the confirmation beeps will not be heard. **Factory Setting:** 3

24. Ext Relay Latch Commands

When set to "Enabled" the Operation Commands (*0 to *1) to Un-Latch or Latch the relay are enabled. These can be entered on an inbound call after the access code is dialed (if programmed).

When set to "Disabled" the Operation Commands (*0 to *1) to Un-Latch or Latch the relay are disabled. Disabling the latch commands can be useful in applications where you want to eliminate the possibility of inadvertently entering a latch command leaving a gate open/closed, etc.

Factory Setting: Enabled

25. Panic Button Mode

Panic Button Mode disabled: Momentarily pressing the hard wired switch will immediately initiate a non-emergency call. Holding the hard wired switch for three or more seconds will initiate an emergency call. Pressing the hard wired switch after a call has been initiated will terminate the call.

Panic Button Mode enabled: The Panic Button mode is intended for emergency applications, therefore non-emergency phone number dialing is disabled. Momentarily pressing the hard wired switch will immediately initiate an emergency call. Pressing the hard wired switch again after the call has been initiated will not terminate the call. The Speaker Mode can be set to one of the OFF modes for the Panic Button Mode.

Factory Setting: Disabled

26. Speaker Mode

The Speaker Mode can be set to one of the following three modes. **Factory Setting:** ON

OFF / Silent Monitoring Mode: In the “OFF” mode the speaker is disabled at all times. However, the speaker can be enabled after communication has been established by entering touch tone command “9#”. The speaker will remain on for the duration of the call.

ON: In the “ON” mode the speaker is enabled during In-bound and Out-bound calls.

OFF Until Answered: In the “OFF Until Answered” mode the speaker will remain silent during dialing and will not turn on until the called party has answered.

27. SIP Paging Volume

The SIP Paging Volume can be set from 0 - 19. 0 = lowest volume setting, 19= highest volume setting. Adjusting this will set the SIP Paging Volume level for SIP Paging and incoming/outgoing phone calls. This setting does not affect multicast volume settings. **Factory Setting:** 1

The SIP Paging Volume can alternatively be set to Auto 0 – 10, 15 or 19. 0 = the lowest automatic volume setting and 10, 15 or 19 = the highest automatic volume setting. With volume set to auto the **300TB-IP** will use its built-in microphone to monitor background room noise and automatically increase or decrease the SIP Paging Volume, incoming/outgoing phone calls and Multicast paging. **Note:** *The minimum volume setting for multicast paging is set separately per multicast IP address and port. See “Paging” menu in Viking IP Programming.*

28. Ring Volume

When the Inbound Call Mode is set to Ring, Ring with AGC or Night Ring timed operation is in effect, the **300TB-IP** will output a loud ring when it is called. The level can be adjusted from 0 - 19. **Factory Setting:** 5

29. Microphone Volume / Automatic Noise Cancelling Mode

The microphone volume can be set from 1 - 9, 1 = lowest volume setting, 9 = the highest volume setting. Alternatively the microphone can be placed in the “Auto” Automatic Noise Cancelling mode. With the mic in the Auto mode, when background noise increases, the mic gain will automatically decrease. When background noise decreases the mic gain will automatically increase. The Auto mode is useful in applications where the background noise level can change drastically. **Factory Setting:** 5

30. Talk / Listen Delay (VOX)

This feature selects switching time between talk and listen modes (VOX switching time). The Talk / Listen Delay can be programmed from 0.1 - 0.9 seconds. **Factory Setting:** 0.5 seconds

31. In-Band Audio Call Progress

The In-Band Audio Call Progress Detection can be set to enabled or disabled. In-Band Audio Call Progress detection should be enabled in applications where you are making an outbound call through your VoIP phone system and are relying on In-Band analog audio for ringback or busy detection. **Factory Setting:** Enabled

32. In-Band Audio Detect Sensitivity

The In-Band Audio Detection level (Sensitivity) can be set from 1 to 9, 1 = minimum setting, 9 = highest setting. Increasing or decreasing the sensitivity may be required in applications where you are making an outbound call through your VoIP phone system and are relying on In-Band analog audio detection. **Factory Setting:** 5

33. Redial Count

With the Redial Count disabled, if the **300TB-IP** speaker is programmed to dial the next number on ring-no-answer and/or busy signal, the **300TB-IP** speaker will continuously call its programmed phone number forever until the call is answered.

The Redial Count is a programmable counter that determines how many times the **300TB-IP** speaker phone will dial its emergency phone number or “Non-Emergency” phone number before it stops the dialing process and hangs up. When the Redial Count has been met, the dialing process stops and the **300TB-IP** speaker phone hangs up.

Factory Setting: Disabled

34. SIP Page / Call Length Timeout

This feature selects the maximum length of time that calls can be connected. Programmable in increments of 1 minute up to a maximum of 9 minutes or disabled. With the call length disabled, the **300TB-IP** speaker must rely on a call ended signal, busy signal, Ring No Answer limit, or touch tone # to hang-up. **Factory Setting:** 3 minutes

35. Inbound Call Mode

The Inbound Call Mode determines how the **300TB-IP** handles incoming SIP calls. One option is to generate a loud ring sound through the speaker. The **300TB-IP** can also auto answer a SIP call to transmit a page, control the relay or listen to transmit audio from the microphone. The last option is the silent monitor mode, which allows callers to listen to the transmit audio from the microphone. The “secure” options for auto answer require the callers to dial the access code in order to transmit a page or activate the optional **RC-4A** relays.

Factory Setting: Auto Answer

Disabled: Inbound SIP calls are not allowed.

Auto Answer: Inbound SIP calls are auto answered on the first ring. This can also be used for Silent Monitoring by changing the speaker mode to “OFF / Silent Monitor”, see page 15. For more security use the Auto Answer Secure Mode.

Auto Answer Secure: Inbound SIP calls are auto answered and the caller must dial the access code in order to listen or talk on the unit.

Ring: In the “Ring” mode the speaker phone will not automatically answer an incoming call but will output a loud ring signal out of the speaker in a factory programmed 2 seconds ON, 4 seconds OFF ring pattern. There are four available ring cadences.

Ring with AGC: In the “Ring with AGC” mode the speaker phone will not automatically answer an incoming call but will output a loud ring signal out of the speaker in a 2 seconds ON, 4 seconds OFF ring pattern. The speaker will automatically increase or decrease the ring volume based on background ambient noise. The call can then be answered by momentarily pressing the “Trig In” button.

36. Ring Cadence

The Ring Cadence can be programmed to one of four different cadences. **Factory Setting:** Normal Ring

Normal Ring (single ring: 2 seconds ON, 4 seconds OFF)

Double Ring (double ring: 1 second ON, 0.5 second OFF, 1 second ON, 3.5 seconds OFF)

Short-Short-Long (triple ring: 0.5 second ON, 0.5 second OFF, 0.5 second ON, 0.5 second OFF, 1 second ON, 3 seconds OFF)

Short-Long-Short (triple ring: 0.5 second ON, 0.5 second OFF, 1 second ON, 0.5 second OFF, 0.5 second ON, 3 seconds OFF)

37. Redial on Ring No Answer

If enabled and a ring-no-answer is detected, the speaker phone will dial the next programmed Emergency phone number or Non-Emergency phone number. A momentary press of the “Trig In” button will dial the Non-Emergency programmed phone number. Pressing and holding the “Trig In” button for 3 or more seconds will dial the Emergency Phone number. **Factory Setting:** 7 (will redial after 7 rings)

38. Redial on Busy

If enabled and a busy is detected, the speaker phone will dial the Emergency phone number. A momentary press of the “Trig In” button will dial the programmed Non-Emergency phone number. Pressing and holding the “Trig In” button for 3 or more seconds will dial the Emergency Phone number. **Factory Setting:** Enabled

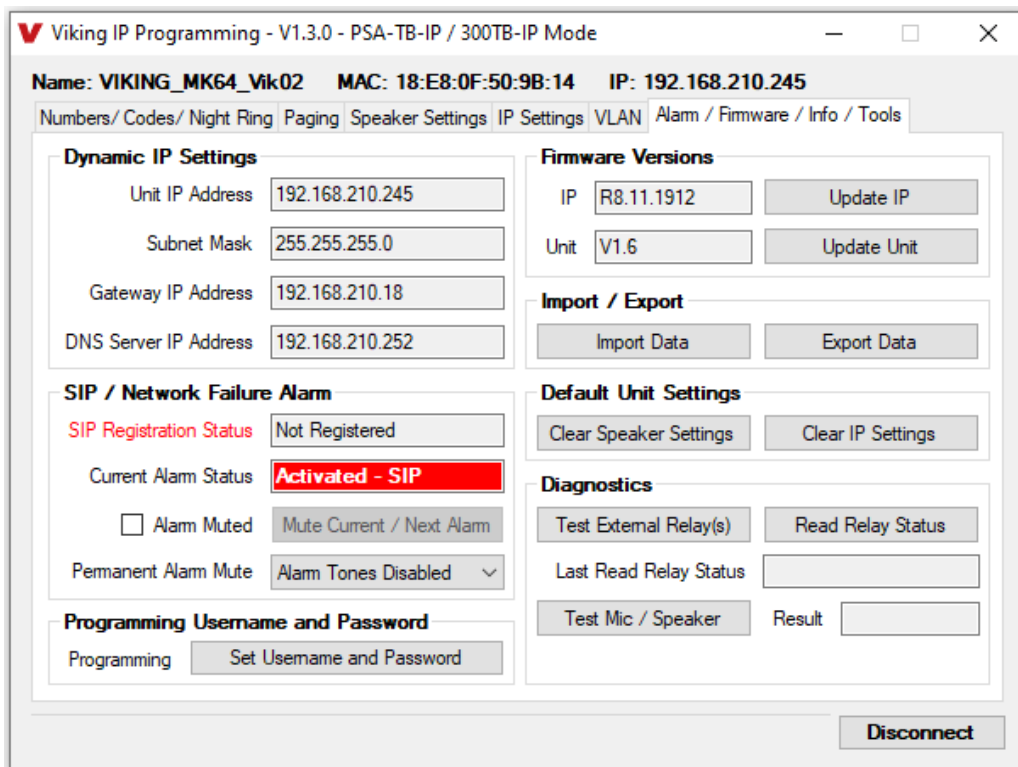

39. Mute Current / Next Alarm

A network failure alarm will be indicated by providing 3 beeps over the speaker every 30 seconds but only when Permanent Alarm Mute is set to Alarm Tones Enabled (Permanent Alarm Mute is set to Alarm Tones Disabled by default). A network failure indicates the unit is not registered to the SIP server or there is a communication failure with the gateway. The three beeps can be muted by clicking on “Mute Current / Next Alarm” button in the IP Programming software or provide a short across the “Trig In” wires for five seconds. The Status LED will continue to flash to assist troubleshooting. The alarm beeps can also be permanently disabled. See Permanent Alarm Mute below. **Factory Setting:** Disabled

40. Permanent Alarm Mute

Permanent Alarm Mute is set to Alarm Tones Disabled by default, so network failure alarms will not be indicated over the speaker. Only the status LED will flash to indicate the network failure. To enable alarm tones over the speaker, select Alarm Tones Enabled.

41. Programming Username and Password to Restrict Access to Programming

To increase security, a username and password can be programmed to limit access to the **300TB-IP** using Viking IP Programming software. When no username and password are programmed and the security code is still set to default (845464), the PC software will not require a username, password or security code when connecting to the **300TB-IP**. If the **300TB-IP** has been programmed with a username and password, a pop up window will ask for the username followed by the password. If the unit’s security code has been changed from default (845464), it will then prompt for the correct security code.

If the username and password are unknown, they can only be erased by resetting all network parameters to default with the reset button (see section E on page 9). If the username and password are known but you wish to erase them, that can be accomplished by exporting the data from the **300TB-IP** (“Alarm / Firmware” tab of Viking IP Programming), resetting all network parameters to default with the reset button (see section E on page 9) and then importing the data back into the speaker.

42. IP Firmware

Update IP is currently not available. The ability to update IP firmware will be made available in a later release of Viking IP Programming software. If an IP firmware update is needed, Viking Technical Support will assist in updating the IP firmware.

43. Unit Firmware

If new **300TB-IP** firmware is available, after opening the programming software a pop up window will ask if you would like to update firmware. Another way to update is accomplished by clicking the speaker firmware “Update Unit” button. You can then browse to the folder that contains the HEX file for updating the unit’s firmware. This method is typically only used when Viking Technical Support has sent you updated firmware.

44. Import / Export

The Import / Export feature is useful for backing up all the **300TB-IP’s** programming or for importing programming when installing multiple units with a majority of the same programming.

45. Clear Speaker Settings

Clicking on the “Clear Speaker Settings” button in programming will reset all of the Programming Features back to their factory default settings. **NOTE:** *This command will not change or reset your IP settings.*

46. Clear IP Settings

Clicking on the “Clear IP Settings” will reset all of the IP settings back to their factory default settings. This also clears paging Group settings and Addresses. **NOTE:** *This will not affect any speaker or paging settings.*

47. Diagnostics

The Diagnostics section in the Viking IP Programming can be used to test the functionality of the mic, speaker and the optional **RC-4A** relays.

A. Outbound SIP Calls

When the hard wired switch connected to the “Trig In” wires is pressed, the **300TB-IP** speaker phone dials a pre-programmed telephone or extension number. When the Panic Button Mode is enabled (see Programming section 25), only emergency calls are possible. When the Panic Button Mode is disabled, the type of call (non-emergency or emergency) depends on the length of time the button or switch is pressed. Momentarily pressing the button or switch will initiate a non-emergency call. Holding the button or switch for 3 seconds or longer will initiate an emergency call. The Call / Status LED will momentarily flash during dialing.

In the event the telephone or extension number is busy or there is ring-no-answer, the unit can be programmed to redial the phone number. The unit then redials pre-programmed number until the call is answered or the programmed Redial Count is met. When the call is answered, the **300TB-IP**'s will automatically light the “Status” LED to show that handsfree communication to personnel is established. When the call has been answered and the Relay Mode is set to Door Strike (see Programming section 20), any of the Operation Commands (see Operation section D) can be entered or the # key can be dialed to force the speaker to hang up.

B. Inbound SIP Calls

How inbound SIP calls are handled depends on the Inbound Call Mode selected (see Programming section 35), the current programming for Night Ring Timed Operation if enabled (see Programming section 17), the current time of day and day of week. If Night Ring Timed Operation is disabled and the Inbound Call Mode is set to Auto Answer, the **300TB-IP** will automatically answer inbound calls, provides a Pre Page Alert Tone if enabled and allows paging and talkback through the unit. When the Inbound Call Mode is set to Auto Answer – Secure, the **300TB-IP** auto answers inbound calls but the party must dial the Access Code before they are allowed to page or receive talkback from the unit. The Inbound Call Mode also has options that allow the unit to output a loud ring on any inbound SIP calls. The Ring option outputs a fixed volume ring and is adjustable (see Programming section 28). The Ring with AGC option makes the **300TB-IP** vary the volume of the loud ring based on the background noise around the unit. If Night Ring Timed Operation is enabled and an inbound SIP call is received between the programmed start and stop times and the current day is a programmed active day, the unit will automatically output a loud ring instead of following the Inbound Call Mode programming. This allows for loud ring at certain times of the day/days of the week and paging with talkback all other times/days of the week.

C. Multicast

The **300TB-IP** can be set to one of two modes for multicasting, Standard or Polycom. Polycom is only used when Polycom IP phones are used. To change to Polycom multicast, go to the “Paging” tab and change the “Multicast Page Type” to Polycom.

Standard Multicast Paging (Factory Setting)

Up to 10 multicast paging groups can be programmed into each unit and each group is assigned a priority level allowing simultaneous arriving multicast pages to be handled based on importance. Low priority groups are often used for low priority streams like background music and high priority groups are used for high priority streams such as emergency messages. Group 0 is the highest priority, and Group 9 is the lowest. A timeout limit can be set and either enabled or disabled for each multicast group. The volume of each group can be programmed and non-emergency SIP calls can be assigned either higher or lower priority than all or some of the multicast groups (see Programming section 10).

Polycom Multicast Paging

Polycom phones send multicast audio to a specific IP address and port. A total of 25 groups can be used and groups 1 through 24 can individually be enabled/disabled in each **300TB-IP**. Group 25 is always enabled, as group 25 is generally used for emergency broadcasts. Any multicast page made from a Polycom phone (on the same LAN) to the programmed IP address, port and to an enabled group will play through the **300TB-IP** speaker. The priority of Polycom sources ranges from group 1 (lowest) to group 25 (highest). Non-emergency SIP calls can be assigned either higher or lower priority than Polycom group 1 through 24 multicast paging (see the table in programming section 11 for Polycom paging priorities). Multicast page timeout can be enabled/disabled globally for groups 1 through 24 (there is no timeout for group 25) and the length of the Multicast page timeout is adjustable. The volume for Polycom multicast is set globally for all groups.

D. Operation Commands (Relay Mode must be set to “Door Strike”)

The following commands can be entered after answering an outbound SIP call from the **300TB-IP** or on an inbound SIP call to the unit, when the Inbound Call Mode is set to auto answer. After the unit auto answers the call, one beep will be heard if Pre Page Alert Tone is enabled. If the Access Code has been disabled, you can now enter the Operation Commands listed below. If an Access Code has been programmed, enter the Access Code digits. Once the correct code has been entered, two beeps will be heard and you can now enter the Operation Commands listed below.

Feature	Tone Tone Command	Description
Activate Ext Relay	** or __ __	Momentarily activate ext relay (1 or 2 digits, factory set to **).
Un-Latch Ext Relay	*0	Un-latch* (deactivate) the ext relay.
Latch Ext Relay	*1	Latch* (continuously activate) the ext relay.
Disconnect	#	Disconnects or forces the speaker to hang up.
Send ID	*	Send I.D. number (if programmed).

* **NOTE:** Latching commands must be enabled in programming.

Troubleshooting

If the unit cannot register with the programmed SIP server, the “Status” LED will blink on and off every two seconds until communication is restored. This alerts a potential user of a problem with the device that will prevent an emergency phone call from being made.

Optional Secure Remote Relay Control Using a Viking Model RC-4A

For applications requiring remote relay control for up to 4 relays, a Viking model **RC-4A** Remote Relay Controller can be used. The relay controller is mounted securely inside the building and connected to the same LAN as the **300TB-IP**. The **300TB-IP** will send an encrypted message to the **RC-4A** to activate its relays which control the door strikes / gates.

Up to four **300TB-IP**'s can communicate with one **RC-4A** allowing you to securely control four entrances.

When using an **RC-4A** for remote relay control the **300TB-IP** should be set to "Ext 1,2,3,4" (see Programming section 19).

For more information on the **RC-4A**, see DOD 582.

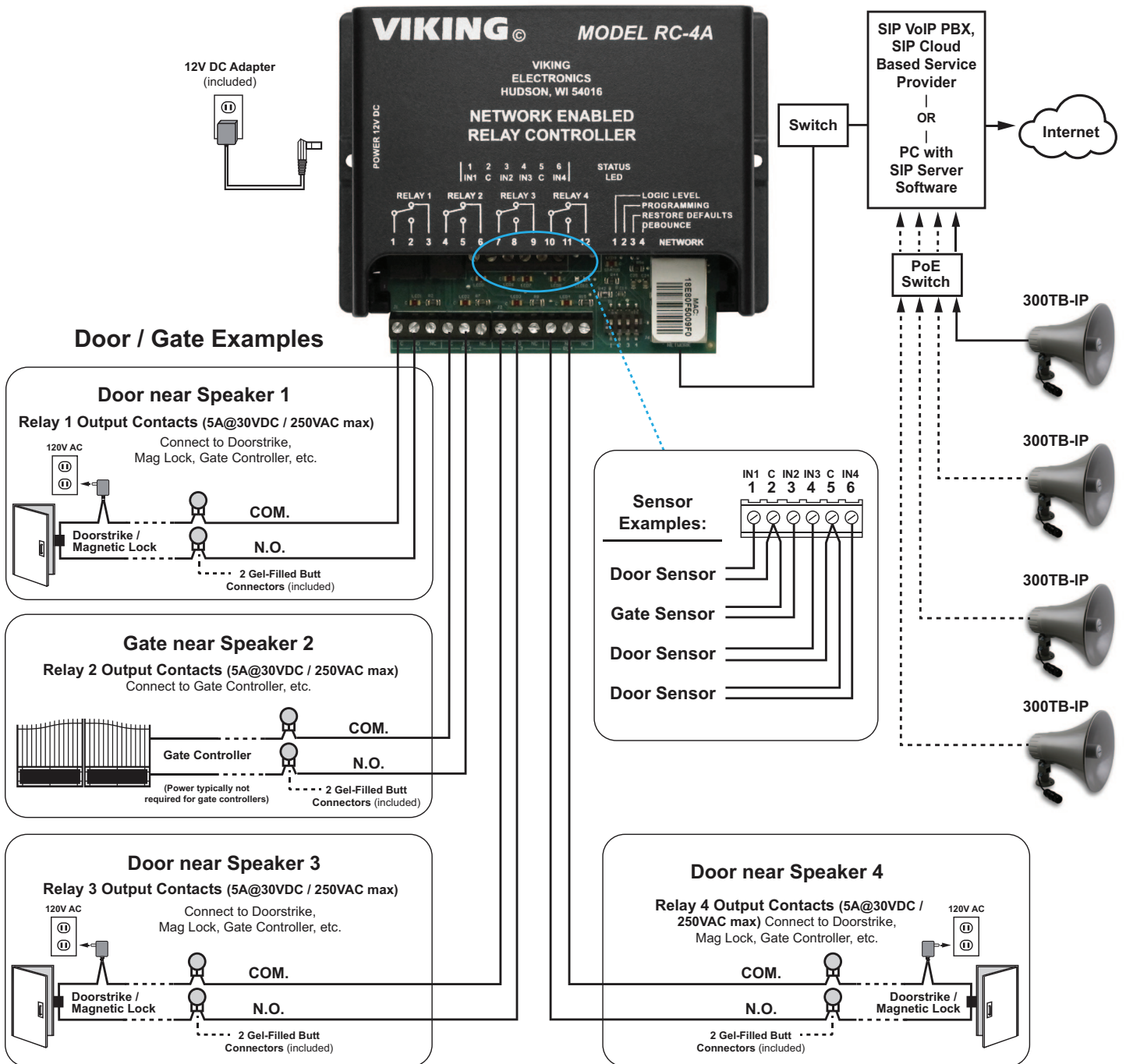

IP Speaker for SIP Endpoint Paging or Multicast Paging / Background Music, and Making Standard or Emergency SIP Calls

The Viking model **40TB-IP** Talk-Back Ceiling/Wall Speaker enables two-way conversations via SIP and also allows for standard paging via multicast. The Line Level Input can be used for background music. The Talk-Back Speaker easily connects with a single CAT5/6 cable from your PoE switch. Its shallow depth allows the speaker to be conveniently mounted in a standard 2" x 4" stud wall or ceiling.

An auxiliary switch input allows a hard wired wall button to initiate a SIP call. A momentary button press will initiate a standard call, and holding the button for 3 or more seconds will initiate an emergency call. The **40TB-IP** LED can be programmed to blink when there is call activity.

The integrated microphone enables talk-back and also monitors room noise to automatically increase the speaker volume when necessary. Line-level audio output connections are provided for connecting to an external amplifier. Speaker output connections are also provided to directly drive additional analog speakers.

A programmable relay output is provided for activating door locks, strobe lights, external amplifiers, etc.

For more info, see **DOD 502**.

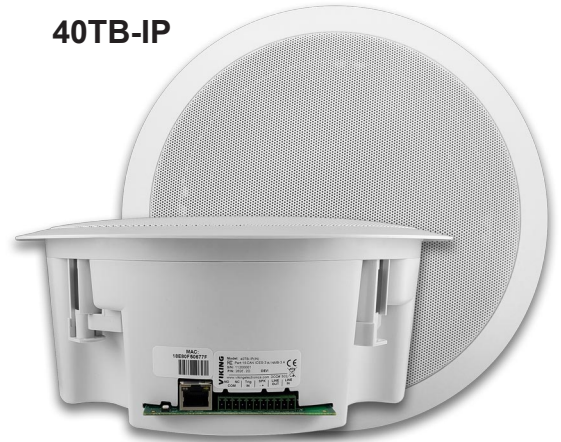

IP Speaker for SIP Endpoint Paging

The Viking model **40-IP** Ceiling/Wall Speaker enables SIP endpoint paging and also allows for standard paging and background music via multicast. The speaker easily connects with a single CAT5/6 cable from your PoE switch. Its shallow depth allows the speaker to be conveniently mounted in a standard 2" x 4" stud wall or ceiling.

Line-level audio output connections are provided for connecting to an external amplifier. Speaker output connections are also provided to directly drive additional analog speakers. The LED on the **40-IP** can be programmed to light during paging.

For more info, see **DOD 503**.



SIP / Multicast Paging Adapter

The Viking model **PA-IP** SIP / Multicast Paging Adapter provides an interface between new VoIP phone systems (hardware or hosted/cloud based) and analog paging systems, eliminating the need for an ATA or FXS port. The **PA-IP** can be used for standard SIP endpoint paging or multicast paging and background music.

The unit easily connects with a single CAT5/6 cable from your PoE switch. The night bell feature is programmable for time of day and day of week to enable loud ringing for after hour incoming calls. Alternatively the night bell feature can be enabled by a contact closure across the trigger input terminals. Line-level audio output connections are provided for connecting to an external amplifier.

A built-in 6 Watt class D amplifier with speaker output connections are also provided to drive up to 6 analog speakers. A programmable relay output is provided for triggering external amplifiers, etc.

For more info, see **DOD 505**.



Related Products

Add High Power Paging, Loud Ringing, and Background Music to SIP Based VoIP Phone Systems or Service Providers

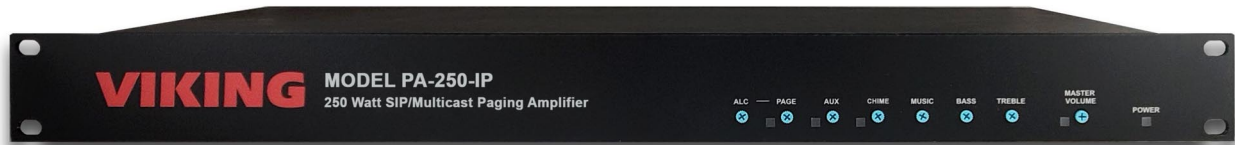

The Viking model **PA-250-IP** SIP/Multicast Paging Amplifier provides up to 250 Watts of loud paging for SIP based VoIP phone systems (hardware or hosted/cloud based service provider). The **PA-250-IP** can be used for standard SIP endpoint paging or multicast paging.

The **PA-250-IP** can drive up to two hundred fifty (250) 70V speakers and/or paging horns (each speaker set to “1 Watt tap”). The small 1U rack size chassis is possible because the **PA-250-IP** uses new amplifier technology that is 3 times more efficient than old designs competitors use. The high efficiency of the **PA-250-IP** means much less heat dissipation, smaller size, higher reliability, and lower cost.

There are many advantages of using a 70V distributed audio paging system, such as being able to put more speakers on a wire run, having longer speaker wire runs, using smaller gauge wire, and being able to set the volume of each speaker independently.

The **PA-250-IP** features individual level controls with LED indicators for each input, automatic peak limiting, multiple amplifier protection modes, an adjustable Automatic Level Control, and Bass & Treble Controls.

The unit easily connects with a single CAT5/6 cable from your network switch. The night ring feature is programmable for time of day and day of week to enable loud ringing for after hour incoming calls.

A 600 Ohm output to allow more paging amplification to be added if needed. The **PA-250-IP** has inputs for Background Music and Aux Input. The Aux Input allows the addition of another audio source such as a clock-controlled tone generator (Viking model **CTG-1A** or **CTG-2A**), or emergency notification system (Viking model **DNA-510**).

For more info, see DOD 501.

2' x 2' Drop-In Ceiling Tile IP Speaker for SIP Endpoint or Multicast Paging and Making Standard and / or Emergency SIP Calls

The Viking model **22TB-IP** Talk-Back 2 x 2 ceiling tile replacement speaker enables two-way conversations and end point paging via SIP, yet also allows for standard paging via multicast. The Line Level Input can be used for background music. The Talk-Back Speaker easily connects with a single CAT5/6 cable from your PoE switch. Its 2' x 2' size, shallow depth and light weight design make for a quick and easy installation in drop/suspended ceilings. The speaker's aesthetically pleasing white grill blends in with existing ceiling tiles and air vents.

An auxiliary switch input allows for a hard wired wall mounted button to initiate a SIP call. A momentary button press will initiate a standard call, and holding the button for 3 or more seconds will initiate an emergency call. The integrated high sensitivity microphone enables talk-back and also monitors room noise to automatically increase the speaker volume when necessary. Line level audio output connections are provided for connecting to an external amplifier. The **22TB-IP** has an integrated 6 watt amplifier allowing its speaker output connections to directly drive up to 5 additional analog speakers. A programmable relay output is provided for activating door locks, strobe lights, external amplifiers, etc. A programmable blue status LED is provided to indicate paging, SIP call and network registration.

For more info, see DOD 508.



22TB-IP

Warranty

IF YOU HAVE A PROBLEM WITH A VIKING PRODUCT, CONTACT VIKING TECHNICAL SUPPORT: 715-386-8666

Our Technical Support Department is available for assistance Monday through Friday 8:00am to 5:00pm central time. So that we can give you better service, before you call please:

1. Know the model number, the serial number and what software version you have (see serial label).
2. Have the Product Manual in front of you.
3. It is best if you are on site.

RETURNING PRODUCT FOR REPAIR

The following procedure is for equipment that needs repair:

1. Customer must contact Viking's Technical Support Department at 715-386-8666 to obtain a Return Authorization (RA) number. The customer MUST have a complete description of the problem, with all pertinent information regarding the defect, such as options set, conditions, symptoms, methods to duplicate problem, frequency of failure, etc.
2. Packing: Return equipment in original box or in proper packing so that damage will not occur while in transit. The original product boxes are not designed for shipping - an overpack box is required to prevent damage in transit. Static sensitive equipment such as a circuit board should be in an anti-static bag, sandwiched between foam and individually boxed. All equipment should be wrapped to avoid packing material lodging in or sticking to the equipment. Include ALL parts of the equipment. C.O.D. or freight collect shipments cannot be accepted. Ship cartons prepaid to:

**VIKING ELECTRONICS
1531 INDUSTRIAL STREET
HUDSON, WI 54016**

3. Return shipping address: Be sure to include your return shipping address inside the box. We cannot ship to a PO Box.
4. RA number on carton: In large printing, write the RA number on the outside of each carton being returned.

RETURNING PRODUCT FOR EXCHANGE

The following procedure is for equipment that has failed out-of-box (within 10 days of purchase):

1. Customer must contact Viking's Technical Support at 715-386-8666 to determine possible causes for the problem. The customer MUST be able to step through recommended tests for diagnosis.
2. If the Technical Support Product Specialist determines that the equipment is defective based on the customer's input and troubleshooting, a Return Authorization (RA) number will be issued. This number is valid for fourteen (14) calendar days from the date of issue.
3. After obtaining the RA number, return the approved equipment to your distributor. Please reference the RA number on the paperwork being shipped back with the unit(s), and also the outside of the shipping box. The original product boxes are not designed for shipping - an overpack box is required to prevent damage in transit. Once your distributor receives the package, they will replace the product over the counter at no charge. The distributor will then return the product to Viking using the same RA number.
4. **The distributor will NOT exchange this product without first obtaining the RA number from you. If you haven't followed the steps listed in 1, 2 and 3, be aware that you will have to pay a restocking charge.**

TWO YEAR LIMITED WARRANTY

Viking warrants its products to be free from defects in the workmanship or materials, under normal use and service, for a period of two years from the date of purchase from any authorized Viking distributor. If at any time during the warranty period, the product is deemed defective or malfunctions, return the product to Viking Electronics, Inc., 1531 Industrial Street, Hudson, WI., 54016. Customer must contact Viking's Technical Support Department at 715-386-8666 to obtain a Return Authorization (R.A.) number.

This warranty does not cover any damage to the product due to lightning, over voltage, under voltage, accident, misuse, abuse, negligence or any damage caused by use of the product by the purchaser or others. This warranty does not cover non-EWP products that have been exposed to wet or corrosive environments. This warranty does not cover stainless steel surfaces that have not been properly maintained.

NO OTHER WARRANTIES. VIKING MAKES NO WARRANTIES RELATING TO ITS PRODUCTS OTHER THAN AS DESCRIBED ABOVE AND DISCLAIMS ANY EXPRESS OR IMPLIED WARRANTIES OR MERCHANTABILITY OR FITNESS FOR ANY PARTICULAR PURPOSE.

EXCLUSION OF CONSEQUENTIAL DAMAGES. VIKING SHALL NOT, UNDER ANY CIRCUMSTANCES, BE LIABLE TO PURCHASER, OR ANY OTHER PARTY, FOR CONSEQUENTIAL, INCIDENTAL, SPECIAL OR EXEMPLARY DAMAGES ARISING OUT OF OR RELATED TO THE SALE OR USE OF THE PRODUCT SOLD HEREUNDER.

EXCLUSIVE REMEDY AND LIMITATION OF LIABILITY. WHETHER IN AN ACTION BASED ON CONTRACT, TORT (INCLUDING NEGLIGENCE OR STRICT LIABILITY) OR ANY OTHER LEGAL THEORY, ANY LIABILITY OF VIKING SHALL BE LIMITED TO REPAIR OR REPLACEMENT OF THE PRODUCT, OR AT VIKING'S OPTION, REFUND OF THE PURCHASE PRICE AS THE EXCLUSIVE REMEDY AND ANY LIABILITY OF VIKING SHALL BE SO LIMITED.

IT IS EXPRESSLY UNDERSTOOD AND AGREED THAT EACH AND EVERY PROVISION OF THIS AGREEMENT WHICH PROVIDES FOR DISCLAIMER OF WARRANTIES, EXCLUSION OF CONSEQUENTIAL DAMAGES, AND EXCLUSIVE REMEDY AND LIMITATION OF LIABILITY, ARE SEVERABLE FROM ANY OTHER PROVISION AND EACH PROVISION IS A SEPARABLE AND INDEPENDENT ELEMENT OF RISK ALLOCATION AND IS INTENDED TO BE ENFORCED AS SUCH.

If trouble is experienced with the **300TB-IP**, for repair or warranty information, please contact:

Viking Electronics, Inc., 1531 Industrial Street, Hudson, WI 54016 Phone: 715-386-8666

WHEN PROGRAMMING EMERGENCY NUMBERS AND (OR) MAKING TEST CALLS TO EMERGENCY NUMBERS:

Remain on the line and briefly explain to the dispatcher the reason for the call. Perform such tests in off-peak hours, such as early morning or late evenings.

PART 15 LIMITATIONS

This equipment has been tested and found to comply with the limits for a Class A digital device, pursuant to Part 15 of the FCC Rules. These limits are designed to provide reasonable protection against harmful interference when the equipment is operated in a commercial environment. This equipment generates, uses, and can radiate radio frequency energy and, if not installed and used in accordance with the instruction manual, may cause harmful interference to radio communications. Operation of this equipment in a residential area is likely to cause harmful interference in which case the user will be required to correct the interference at his own expense.

CANADA

This class A digital apparatus complies with Canadian ICES-003. Cet appareil numérique de la classe A est conforme a la norme NMB-003 du Canada.

Product Support: 715-386-8666

Due to the dynamic nature of the product design, the information contained in this document is subject to change without notice. Viking Electronics, and its affiliates and/or subsidiaries assume no responsibility for errors and omissions contained in this information. Revisions of this document or new editions of it may be issued to incorporate such changes.