

## MediaPack 124 (MP-124)





---

## Table of Contents

---

<b>1</b>	<b>Introduction.....</b>	<b>9</b>
<b>2</b>	<b>Unpacking the Device .....</b>	<b>11</b>
<b>3</b>	<b>Physical Description .....</b>	<b>13</b>
3.1	Physical Dimensions and Operating Environment.....	13
3.2	Front Panel .....	13
3.2.1	Reset Pinhole Button .....	13
3.2.2	LEDs .....	14
3.3	Rear Panel.....	15
3.3.1	Ethernet LED.....	16
<b>4</b>	<b>Mounting the Device .....</b>	<b>17</b>
4.1	Desktop Mounting.....	17
4.2	19-inch Rack Mounting .....	17
<b>5</b>	<b>Cabling the Device .....</b>	<b>19</b>
5.1	Power Surge Protection and Grounding Connections .....	19
5.1.1	Device Connected to MDF through AudioCodes FXS Patch Panel .....	21
5.1.2	Device Connected Directly to MDF .....	22
5.2	Connecting Device to Ethernet Network .....	23
5.3	Connecting Device to FXS Equipment .....	24
5.3.1	Connecting FXS Interfaces using AudioCodes FXS Patch Panel .....	25
5.3.2	Connecting FXS Interfaces Directly to MDF .....	27
5.3.3	Securing Telco Cable to Connector with Velcro Strap.....	29
5.3.4	Connecting FXS Interfaces using a Mini Patch Panel .....	32
5.4	Connecting Device to PC for Serial Communication .....	34
5.5	Connecting Device to Power.....	36
5.5.1	AC Power Supply .....	37
5.5.2	DC Power Supply .....	38

---

## List of Figures

---

Figure 3-1: Front Panel .....	13
Figure 3-2: Rear Panel of AC-Powered Model .....	15
Figure 3-3: Rear Panel of DC-Powered Model .....	15
Figure 4-1: Desktop Mounting .....	17
Figure 4-2: Attached Brackets for Rack Installation .....	17
Figure 5-1: Surge Protection and Grounding using AudioCodes FXS Patch Panel .....	21
Figure 5-2: Surge Protection and Grounding Connected Directly to MDF .....	22
Figure 5-3: RJ-45 Connector Pinouts for Ethernet Interface .....	23
Figure 5-4: Connecting Device to Ethernet Network .....	23
Figure 5-5: 50-pin Telco Connector .....	24
Figure 5-6: Orderable FXS Patch Panel .....	25
Figure 5-7: Connecting Device to FXS Patch Panel .....	26
Figure 5-8: Connecting Analog Equipment to FXS Patch Panel .....	27
Figure 5-9: Connecting Device Directly to MDF for FXS Cabling .....	28
Figure 5-10: 50-Pin Telco Cable Secured to Device's Connector using Orderable Velcro Strap .....	29
Figure 5-11: Removing Bail Locks from Telco Connector .....	29
Figure 5-12: Attaching Bracket over Telco Connector (e.g., Short Screws) .....	30
Figure 5-13: Feeding Velcro Strap through Bracket Slots .....	30
Figure 5-14: Sliding Cable through Velcro Strap .....	30
Figure 5-15: Attaching Cable Connector to Device's Telco Connector .....	30
Figure 5-16: Pulling Velcro Strap to Reduce Slack over Cable .....	31
Figure 5-17: Feeding Velcro Strap through Strap Buckle .....	31
Figure 5-18: Attaching Velcro Strap to Itself .....	31
Figure 5-19: Mini Patch Panel for FXS Interfaces .....	32
Figure 5-20: Connecting FXS Lines using Mini Patch Panel .....	33
Figure 5-21: RJ-45 to DB-9 Serial Cable Adapter .....	34
Figure 5-22: Connecting Device for Serial Communication .....	35
Figure 5-23: Connecting Device to AC Power Supply .....	37
Figure 5-24: Inserting DC Wires into DC Terminal Block .....	38
Figure 5-25: Wired DC Power Terminal Block Attached to Device .....	38

---

## List of Tables

---

Table 3-1: Physical Dimensions and Operating Environment .....	13
Table 3-2: Front-Panel LED Descriptions .....	14
Table 3-3: Rear-Panel Description .....	15
Table 3-4: Rear-Panel Ethernet LED Description .....	16
Table 5-1: 50-pin Telco Connector Pinouts .....	24
Table 5-2: RJ-45 to DB-9 Serial Cable Connector Pinouts .....	34
Table 5-3: Power Specifications .....	36

## Notice

Information contained in this document is believed to be accurate and reliable at the time of printing. However, due to ongoing product improvements and revisions, AudioCodes cannot guarantee accuracy of printed material after the Date Published nor can it accept responsibility for errors or omissions. Updates to this document can be downloaded from <https://www.audiocodes.com/library/technical-documents>.

This document is subject to change without notice.

Date Published: September-05-2022

## WEEE EU Directive

Pursuant to the WEEE EU Directive, electronic and electrical waste must not be disposed of with unsorted waste. Please contact your local recycling authority for disposal of this product.

## Customer Support

Customer technical support and services are provided by AudioCodes or by an authorized AudioCodes Service Partner. For more information on how to buy technical support for AudioCodes products and for contact information, please visit our website at <https://www.audiocodes.com/services-support/maintenance-and-support>.

## Stay in the Loop with AudioCodes



## Abbreviations and Terminology

Each abbreviation, unless widely used, is spelled out in full when first used.

Throughout this manual, unless otherwise specified, the term *device* refers to the MediaPack MP-124 gateway.

## Related Documentation

Document Name
SIP Release Notes
MP-11x & MP-124 SIP User's Manual
MP-124 SIP Analog Gateway Quick Guide

## Notes and Warnings



**Warning:** Read and adhere to all warning statements in this document before installing the device.



**Warning:** The device is intended to be installed only in an **indoor** environment, where the ambience temperature and humidity are controlled.



**Warning: (MP-124 Rev. E Only)** Routing FXS telephony cables outdoors can be done only in conjunction with a three-electrode Gas Discharge Tube (GDT) rated at 350V located at the entry point of the two-wire into the building, and properly grounded. When done correctly, the installation will meet ITU-T K.21 requirements.



**Warning:** The Ethernet port interface cabling must be routed **only** indoors and must **not** exit the building.



### Caution Electrical Shock

Do not open or disassemble this device. The device carries high voltage and contact with internal components may expose you to electrical shock and bodily harm.



**Warning:** The device is supplied as a sealed unit and must only be serviced by qualified service personnel.



**Warning:** Disconnect the device from the mains and Telephone Network Voltage (TNV) before servicing.

## Regulatory Information

The Regulatory Information can be downloaded from AudioCodes [website](#).

## Document Revision Record

LTRT	Description
59815	Updates for Version 6.6.
59840	FXS warning statement added; power surge drawings updated.
59841	MP-124 Rev. E model added.
59842	Velcro hook-and-loop cable tie for Telco connector updated.
59843	Max. power consumptions updated.
59844	Channels LED numbers when SRTP enabled.
59845	AC power cable warning (Japanese); MP-124 Rev. E supported software.
59846	Surge protection note for MP-124 Rev. E.
59847	Logo updated; mini-patch panel.
59848	Circa note
59850	DC power added to MP-124 Rev. E; MP-124 Rev. D removed.
59851	Grounding notes
59852	Channels LED numbers when SRTP enabled.
59853	Ethernet cable type for LAN; trademark; USA address

## Documentation Feedback

AudioCodes continually strives to produce high quality documentation. If you have any comments (suggestions or errors) regarding this document, please fill out the Documentation Feedback form on our website at <https://online.audiocodes.com/documentation-feedback>.



# 1 Introduction

This document provides a hardware description of the MediaPack MP-124 product (hereafter, referred to as *device*) and provides step-by-step instructions on cabling the device.

**Note:**

- MP-124 Rev. E has replaced MP-124 Rev. D.
- MP-124 Rev. E is supported **from** SIP Software Version 6.60A.301.

**This page is intentionally left blank.**

## 2 Unpacking the Device

Follow the procedure below for unpacking the device.

➤ **To unpack MP-124:**

1. Open the shipping carton and carefully remove the packing materials.
2. Remove the MP-124 unit from the carton.
3. Check that there is no equipment damage.
4. Ensure that in addition to the MP-124 unit, the package contains the following items:
  - AC-powered model: AC power cord
  - DC-powered model: unwired DC terminal block with two crimping screws
  - Two short equal-length brackets and bracket-to-device screws for 19-inch rack installation
  - Regulatory Information document
5. Check, retain and process any documents.
6. Notify AudioCodes or your local supplier of any damage or discrepancies.

**This page is intentionally left blank.**

## 3 Physical Description

This chapter provides a physical description of the device.

### 3.1 Physical Dimensions and Operating Environment

The device's physical dimensions and operating environment are listed in the table below:

**Table 3-1: Physical Dimensions and Operating Environment**

Physical Specification	Description
Dimensions (H x W x D)	44 x 445 x 269 mm (1.73 x 17.5 x 10.6 in.)
Weight	1.8 kg (4 lbs.)
Environmental	<ul style="list-style-type: none"> <li>▪ Operational: 5 to 40°C (41 to 104°F)</li> <li>▪ Storage: -25 to 85°C (-13 to 185°F)</li> <li>▪ Humidity: 10 to 90% non-condensing</li> </ul>

### 3.2 Front Panel

The device's front panel is shown in the figure below and described in the subsequent subsections.

**Figure 3-1: Front Panel**

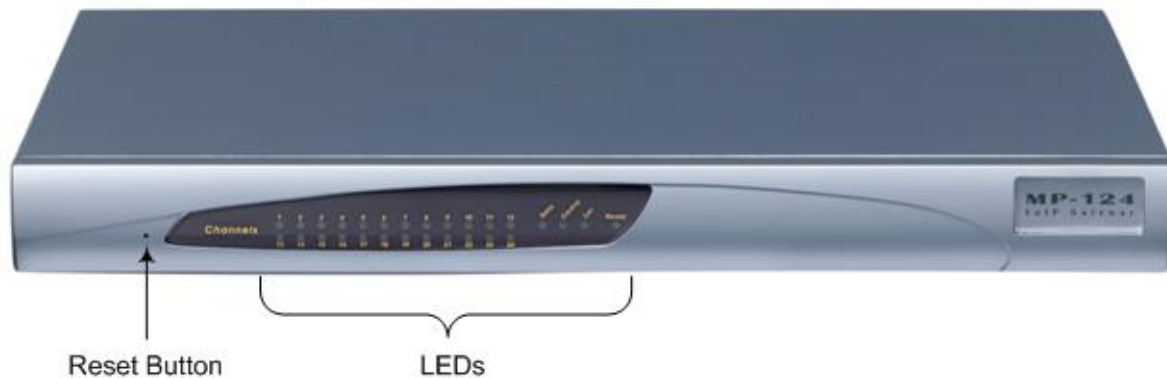

#### 3.2.1 Reset Pinhole Button

The reset pinhole button enables you to reset the device or restore the device to factory default settings. For more information, refer to the *User's Manual*.

### 3.2.2 LEDs

The LEDs on the front panel are described in the table below.

**Table 3-2: Front-Panel LED Descriptions**

Label	Color	State	Function
Ready	Green	On	Device powered on, self-test OK.
	Orange	Blinking	Software loading/initialization.
	Red	On	Malfunction.
LAN	Green	On	Valid 10/100Base-TX Ethernet connection.
	Red	On	Malfunction.
Control	Green	Blinking	Sending and receiving SIP messages.
	-	Off	No traffic.
Data	Green	Blinking	Transmitting RTP packets.
	Red	Blinking	Receiving RTP packets.
	-	Off	No traffic.
Channels 1-24	Green	On	Telephone in off-hook position or ringing.
	Red	On	One of the following: <ul style="list-style-type: none"> <li>▪ Line malfunction.</li> <li>▪ SRTP is enabled and device resources (DSPs) are currently unavailable for calls on these ports (their resources are "borrowed" for SRTP functionality). This LED state applies to <b>Channels 18 to 24</b> LEDs.</li> </ul>
	-	Off	Normal.

### 3.3 Rear Panel

The device's rear panel provides the port interfaces, as shown below and described in the subsequent table for the AC- and DC-powered models.

- **AC-powered model:**

**Figure 3-2: Rear Panel of AC-Powered Model**

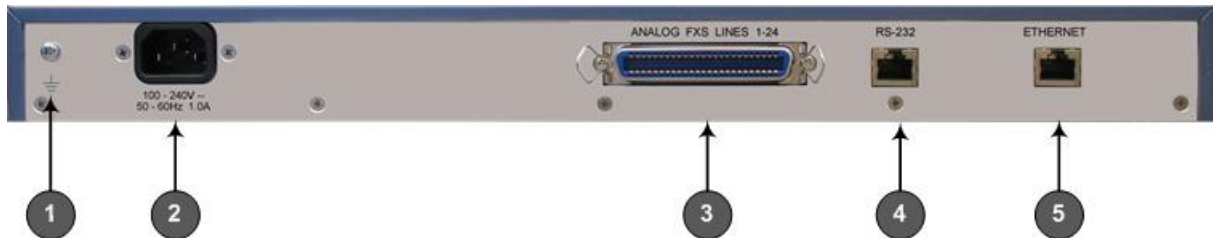

- **DC-powered model:**

**Figure 3-3: Rear Panel of DC-Powered Model**

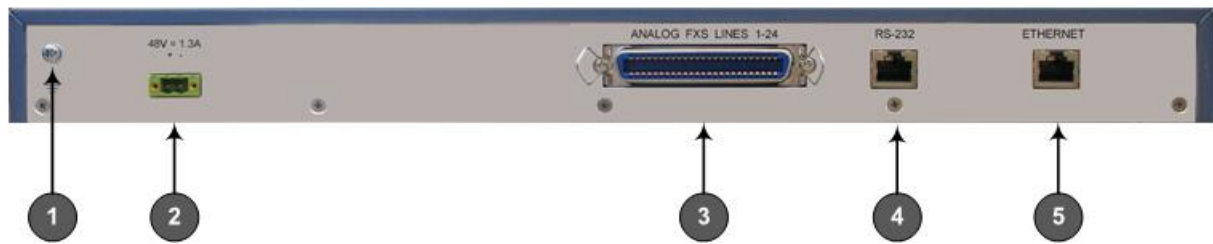

**Table 3-3: Rear-Panel Description**

Item #	Label	Component Description
1		Protective earthing screw (mandatory for all installations). Accepts a 6-32 UNC screw.
2	<b>100-240 V~ 50 - 60Hz 1A</b>	AC power supply socket. <b>Note:</b> Applicable only to the AC-powered model.
	<b>48V 1.3A</b>	DC inlet for a DC terminal block. <b>Note:</b> Applicable only to the DC-powered model.
3	<b>ANALOG FXS LINES 1-24</b>	50-pin Telco connector, providing up to 24 FXS analog lines.
4	<b>RS-232</b>	RJ-45 port for serial (RS-232) communication.
5	<b>ETHERNET</b>	RJ-45 port for 10/100Base-TX Ethernet interface.

### 3.3.1 Ethernet LED

The RJ-45 Ethernet port for Ethernet interface (labeled **ETHERNET**) provides LEDs that indicate Ethernet status, as described in the table below.

**Table 3-4: Rear-Panel Ethernet LED Description**

Label	Color	State	Function
ETHERNET	Green	On	Valid 10/100Base-TX Ethernet connection.
	Red	On	Malfunction.



## 4 Mounting the Device

The device can be mounted in one of the following ways:

- Desktop mounting – see 'Desktop Mounting' on page 17
- Installed in a standard 19-inch rack – see '19-inch Rack Mounting' on page 17

### 4.1 Desktop Mounting

For desktop mounting, no brackets are required. Simply place the device on a desktop in the required position.

**Figure 4-1: Desktop Mounting**



### 4.2 19-inch Rack Mounting

The device can be installed in a standard 19-inch rack, by using two short, equal-length brackets (supplied). The figure below shows the device with the brackets attached on its side panels for rack installation:

**Figure 4-2: Attached Brackets for Rack Installation**





## Rack Mount Safety Instructions

When installing the chassis in a rack, implement the following safety instructions:

- **Elevated Operating Ambient** - If installed in a closed or multi-unit rack assembly, consideration should be given to installing the equipment in an environment compatible with the maximum ambient temperature (T<sub>ma</sub>) of 40°C (104°F).
- **Reduced Air Flow** - Installation of the equipment in a rack should be such that the amount of air flow required for safe operation on the equipment is not compromised. Avoid stacking equipment one on top of the other and make sure to keep the ventilation openings free from cables or any objects to allow free air circulation.
- **Mechanical Loading** - Mounting of the equipment in the rack should be such that a hazardous condition is not **achieved** due to uneven mechanical loading.
- **Circuit Overloading** - Consideration should be given to the connection of the equipment to the supply circuit **and** the effect that overloading of the circuits might have on overcurrent protection and supply wiring. Appropriate consideration of equipment nameplate ratings should be used when addressing this concern.
- **Connection to Protective Earth** - To avoid injury, electrical shock, and damage to the device, reliable earthing of rack-mounted equipment should be maintained. Attention should be given to supply connections other than direct connections to the branch circuit (e.g., use of power strips.)

### ➤ To install mount the device in a 19-inch rack:

1. On one side of the chassis, locate the two mounting screws (nearest to the front panel).
2. Remove the two screws.
3. Insert the peg on one of the brackets into the third air vent down on the column of air vents nearest the front panel.
4. Swivel the bracket until the holes in the bracket align with the two empty screw holes on the chassis.
5. Use the supplied screws to attach the bracket to the side of the chassis.
6. Repeat steps 1 through 5 to attach the second bracket to the other side of the chassis.
7. Position the device in the rack and line up the bracket holes with the rack frame holes.
8. Use four standard rack screws (not supplied) to attach the device to the rack.

## 5 Cabling the Device

This section provides cabling instructions for the device.

### 5.1 Power Surge Protection and Grounding Connections

This section describes grounding and power surge protection.



**Note:** This section is applicable only to MP-124 Rev. E (as it supports outdoor FXS line cabling, unlike the MP-124 Rev. D model).



**Warning:** For the AC powered model, ensure that you connect the device to an electrical socket outlet that provides protective earthing (grounding). Prior to connecting power, refer to the Regulatory Information on AudioCodes website.

- **Finland:** "Laite on liltettava suojavaadoituskoskettimilla varustettuun pistorasiaan."
- **Norway:** "Apparatet rna tilkoples jordet stikkontakt."
- **Sweden:** "Apparaten skall anslutas till jordat uttag."



**Warning:**

- The equipment must be installed only in telecommunication sites/ centers in compliance with ETS 300-253 requirements "Earthing and Bonding of Telecommunication Equipment in Telecommunication Centers".
- Prior to installation, earth loop impedance test must be performed by a certified electrician to ensure grounding suitability at the power outlet intended to feed the unit. It is essential that the impedance will be kept below 0.5 ohms!
- Proper grounding is crucial to ensure the effectiveness of the lightning protection, connect the unit permanently to ground as per the illustration in this section.
- **(MP-124 Rev. E Only)** The device includes an integrated secondary surge protection, but does not include primary telecom protection. To comply with ITU-K.21 requirements when the telephone lines are routed outside the building, it is essential to install additional protection using a three-electrode Gas Discharge Tube (GDT) rated 350V as a primary protection on the MDF, located at the entrance point of telephone wiring to the building. The center pin of the GDT must be connected to ground as per the illustration in this section.
- Failing to install primary surge protectors, and failing to comply with the grounding instructions or any other installation instructions, may cause permanent damage to the device.
- As most of the installation is the responsibility of the customer, AudioCodes can assume responsibility for damage only if the customer can establish that the device does not comply to the standards specified above (and the device is within the hardware warranty period).
- The device complies with protection levels as required by EN 55024/EN 300386. Higher levels of surges may cause damage to the unit.

Lightning is the transient passage of electrical current between a cloud and the surface of the earth. Part of the lightning current can be carried inside a building from electrical lines and analog and/or digital telephone lines located outside. This direct injection of lightning current inside a building can cause considerable damage to electronic circuits and equipment.

The device must be installed in the Telecommunication rack. The device's grounding screw must be connected to the equipotential grounding bus bar located in the Telecommunication rack, using a **wire of 6 mm<sup>2</sup>** surface wire. This line must be connected to the equipotential bus bar of the electrical circuit board located in the Telecommunication room, using a stranded cable with **surface area of 25 mm<sup>2</sup>**. The length of this cable must be as short as possible (**no longer than 3 meters**).

The device chassis is equipped with a protective earthing screw. Ensure that you connect this to the grounding point using a suitable wire. Fasten the cable securely using a 6-32 UNC screw.

The grounding and lightning protection cabling setup for the device depends on whether AudioCodes orderable FXS Patch Panel (see Section 5.1.1) or a third-party MDF (see Section 5.1.2) is used.

### 5.1.1 Device Connected to MDF through AudioCodes FXS Patch Panel

The grounding and lightning protection cabling setup for connecting the device to the MDF through AudioCodes orderable FXS Patch Panel is shown below:

**Figure 5-1: Surge Protection and Grounding using AudioCodes FXS Patch Panel**

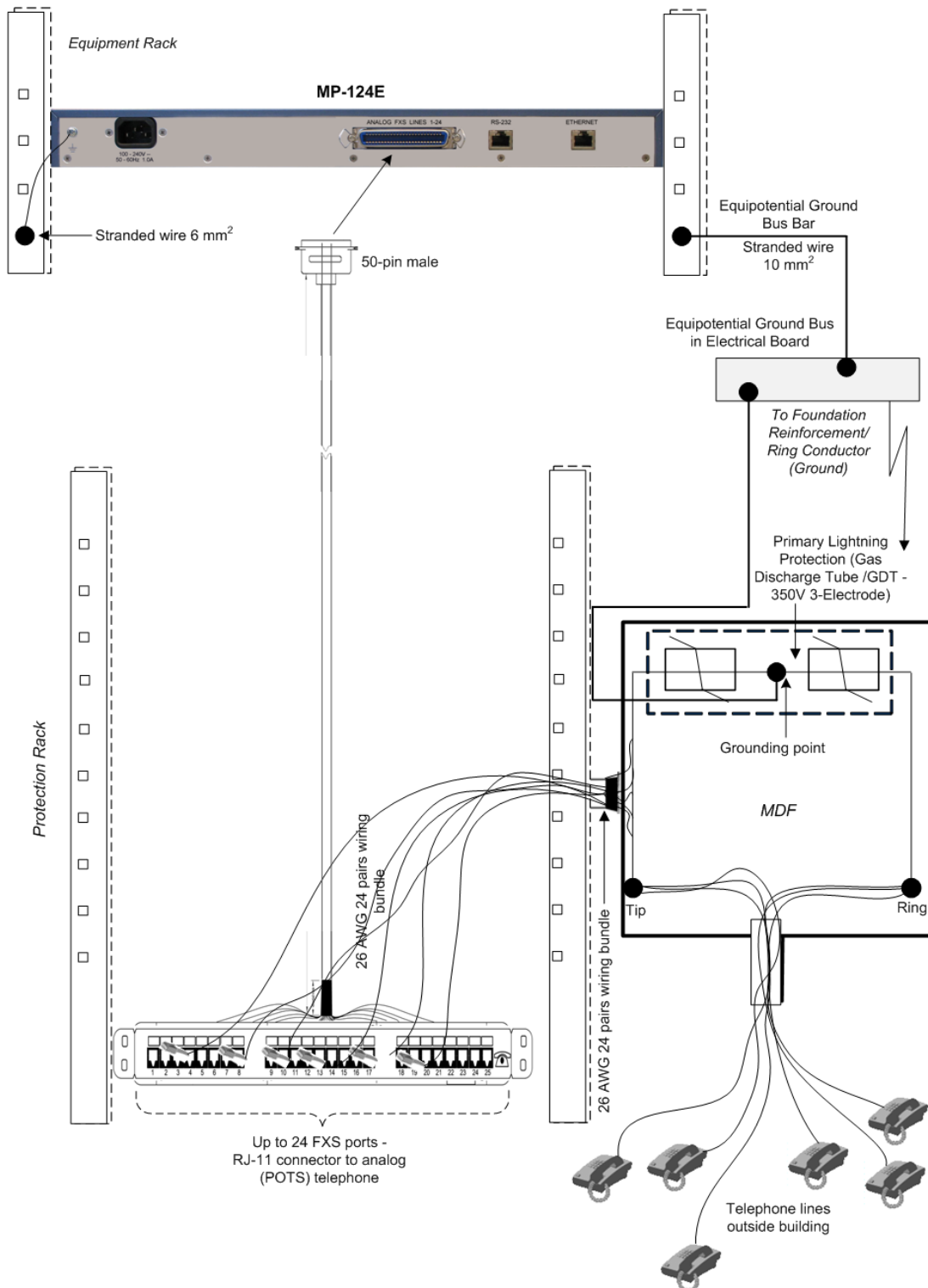

### 5.1.2 Device Connected Directly to MDF

The grounding and lightning protection cabling setup for connecting the device directly to a third-party MDF is shown below:

**Figure 5-2: Surge Protection and Grounding Connected Directly to MDF**

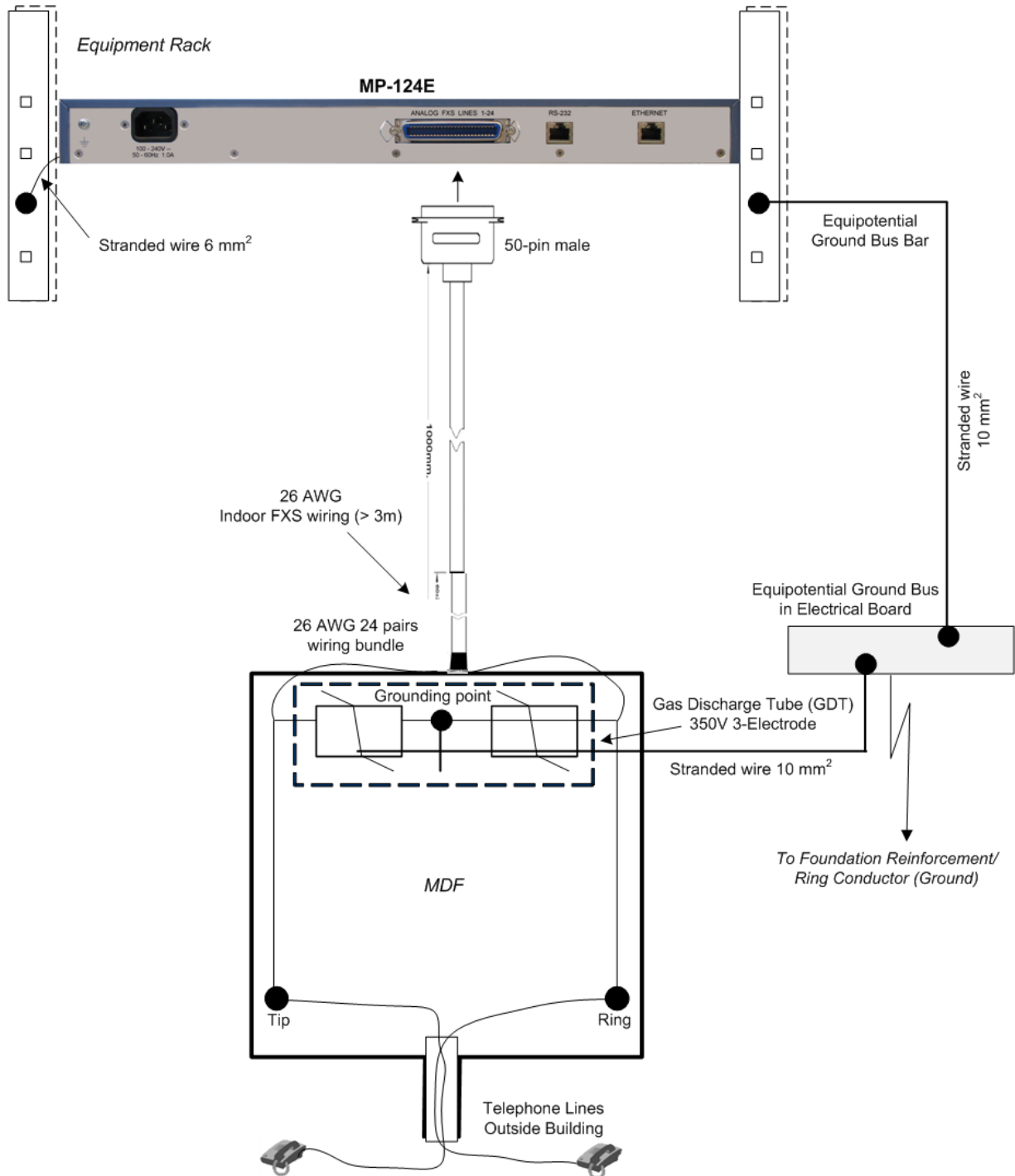

## 5.2 Connecting Device to Ethernet Network

The procedure below describes how to connect the device directly to the Ethernet network.

- **Cable:** Straight-through Ethernet cable
- **Connector:** RJ-45
- **Connector Pinouts:**

**Figure 5-3: RJ-45 Connector Pinouts for Ethernet Interface**

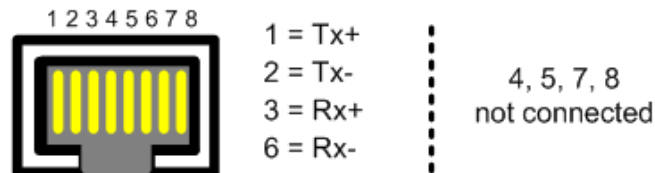

➤ **To connect the device to the Ethernet network:**

1. Connect one end of the RJ-45 Ethernet cable to the Ethernet port (labeled **ETHERNET**).

**Figure 5-4: Connecting Device to Ethernet Network**



2. Connect the other end of the cable to the Ethernet network.

### 5.3 Connecting Device to FXS Equipment

The device interfaces with the FXS analog telephone equipment (e.g., fax machines, modems, or telephones) through its 50-pin Telco connector. To connect to the equipment, you can use your own third-party, MDF connector cable or you can use AudioCodes' MP-124 FXS Patch Panel (ordered separately from AudioCodes).



#### Safety Notice

To protect against electrical shock and fire, use a 26 AWG min. wire to connect analog FXS lines to the 50-pin Telco connector or to the RJ-11 connector.



**Note:** If SRTP is enabled, the device "borrows" resources (DSPs) for this functionality from ports 18 through 24, making these ports unavailable for calls.

- Connector: 50-pin Telco

Figure 5-5: 50-pin Telco Connector

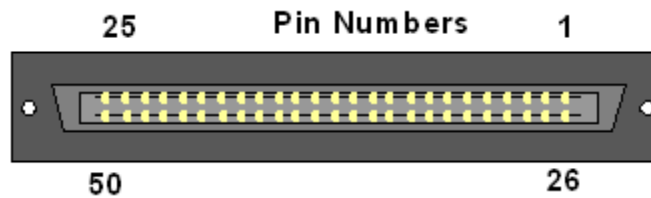

- Connector Pinouts:

Table 5-1: 50-pin Telco Connector Pinouts

Phone Channel	Connector Pins	Phone Channel	Connector Pins
1	1/26	13	13/38
2	2/27	14	14/39
3	3/28	15	15/40
4	4/29	16	16/41
5	5/30	17	17/42
6	6/31	18	18/43
7	7/32	19	19/44
8	8/33	20	20/45
9	9/34	21	21/46
10	10/35	22	22/47
11	11/36	23	23/48
12	12/37	24	24/49



- **Cable:**
  - Third-party, MDF connector
  - AudioCodes MP-124 FXS Patch Panel:

**Figure 5-6: Orderable FXS Patch Panel**

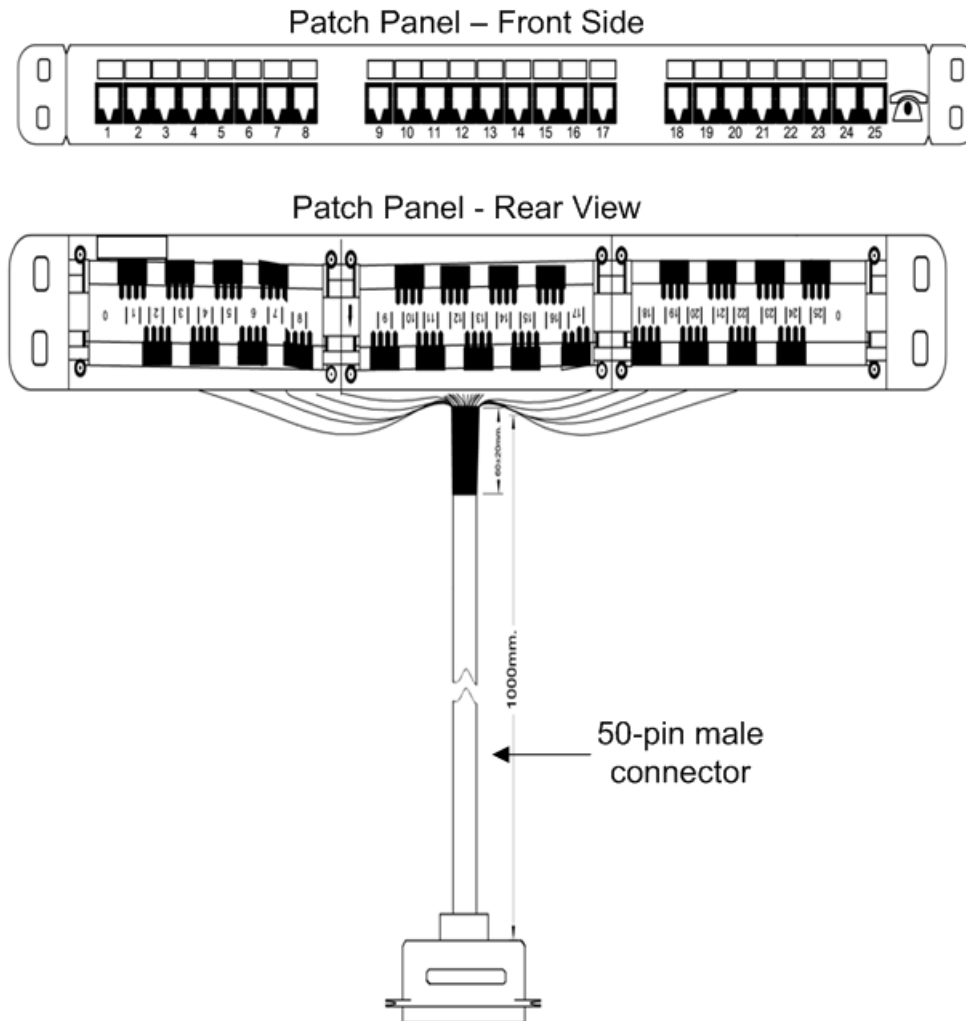

### 5.3.1 Connecting FXS Interfaces using AudioCodes FXS Patch Panel

If you have purchased AudioCodes FXS Patch Panel, follow the instructions below for connecting the FXS analog equipment to the device through the Patch Panel.



**Note:** The LEDs on the FXS Patch Panel front panel are disabled.

- **To connect the device to FXS interfaces using the FXS Patch Panel:**
  1. Mount the Patch Panel in a 19-inch rack, using the integrated mounting brackets on either side of the unit.
  2. Insert and fasten the Patch Panel's 50-pin male connector to the 50-pin female Telco connector on the device's rear panel (labeled **ANALOG FXS LINES 1-24**):



**Note:** The following figure illustrates outdoor FXS cabling installations. For indoor FXS cabling installations, primary lightning protection is not required.

**Figure 5-7: Connecting Device to FXS Patch Panel**

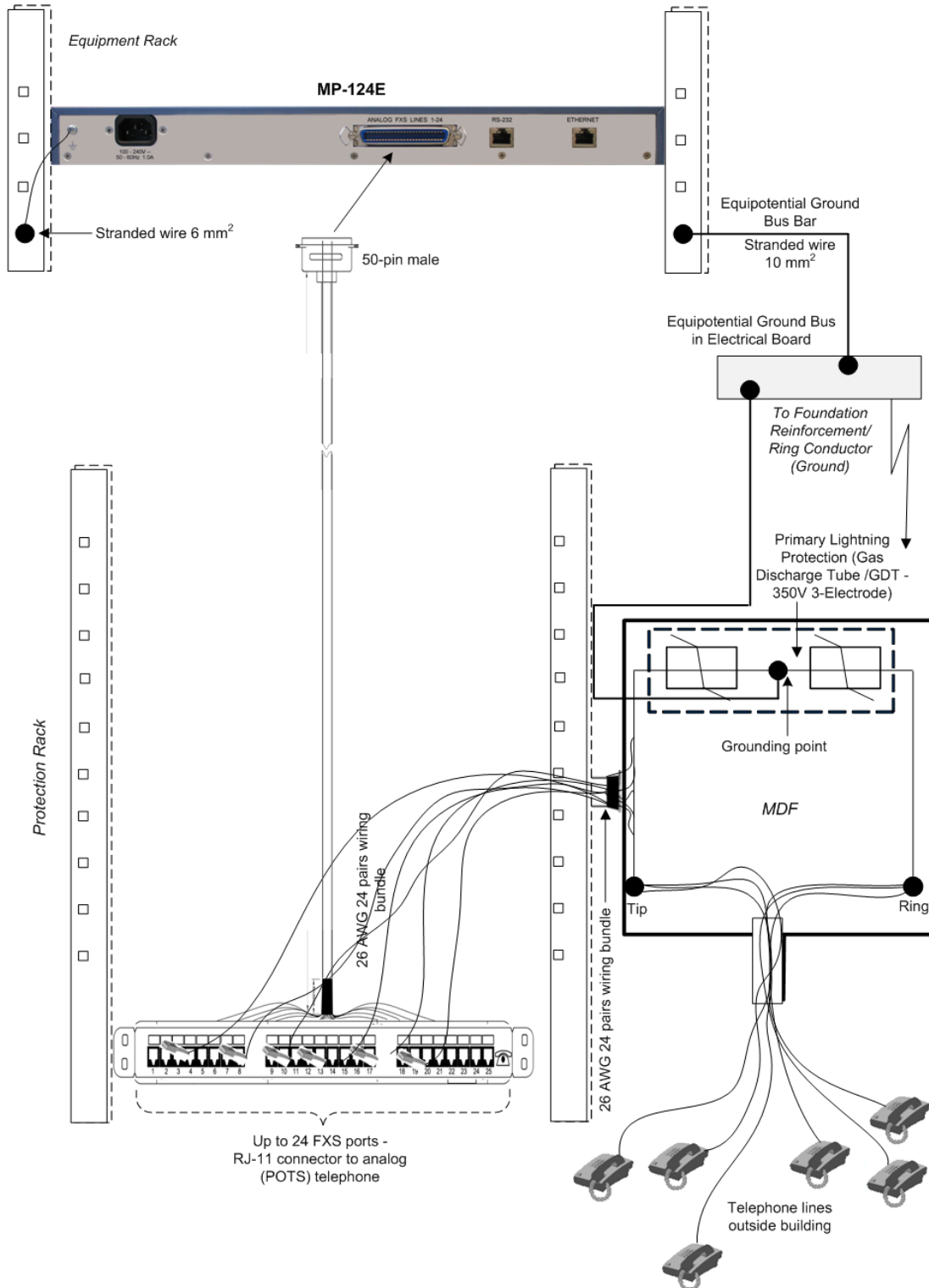

3. Connect your analog equipment to the Patch Panel, by plugging in each RJ-11 connector into the RJ-11 sockets on the Patch Panel's front panel:

**Figure 5-8: Connecting Analog Equipment to FXS Patch Panel**

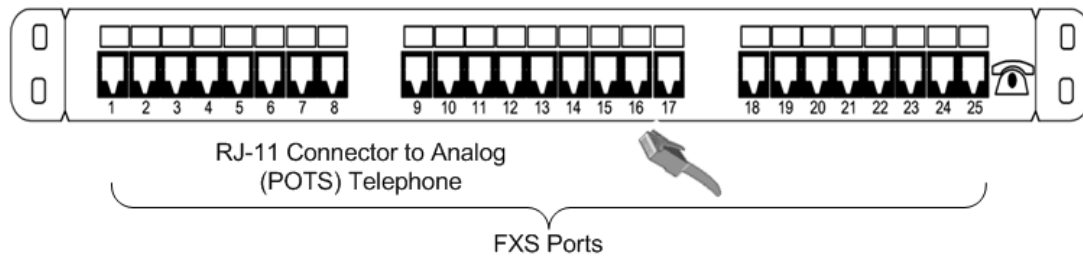

### 5.3.2 Connecting FXS Interfaces Directly to MDF

If you are using your own third-party MDF, follow the instructions below for connecting the FXS analog equipment to the device directly through the MDF.



**Warning:** To reduce noise interference, use a twisted pair Octopus cable that is terminated on a metal-hooded 50-pin Telco connector.

➤ **To connect FXS interfaces directly to the MDF:**

1. Wire the 50-pin Telco connectors according to the pinouts in [Table 5-1](#).
2. Connect the wire-pairs at the other end of the cable to a male 50-pin Telco connector (not supplied).
3. Insert and fasten the male connector to the female 50-pin Telco connector on the device's rear panel (labeled **ANALOG FXS LINES 1-24**).
4. Attach each pair of wires from a 25-pair Octopus cable (not supplied) to its corresponding socket on the MDF.

- 5. Connect the telephone lines from the MDF to the analog equipment, by inserting each RJ-11 connector on the 2-wire line cords to the RJ-11 sockets on the front of the MDF:

**Figure 5-9: Connecting Device Directly to MDF for FXS Cabling**

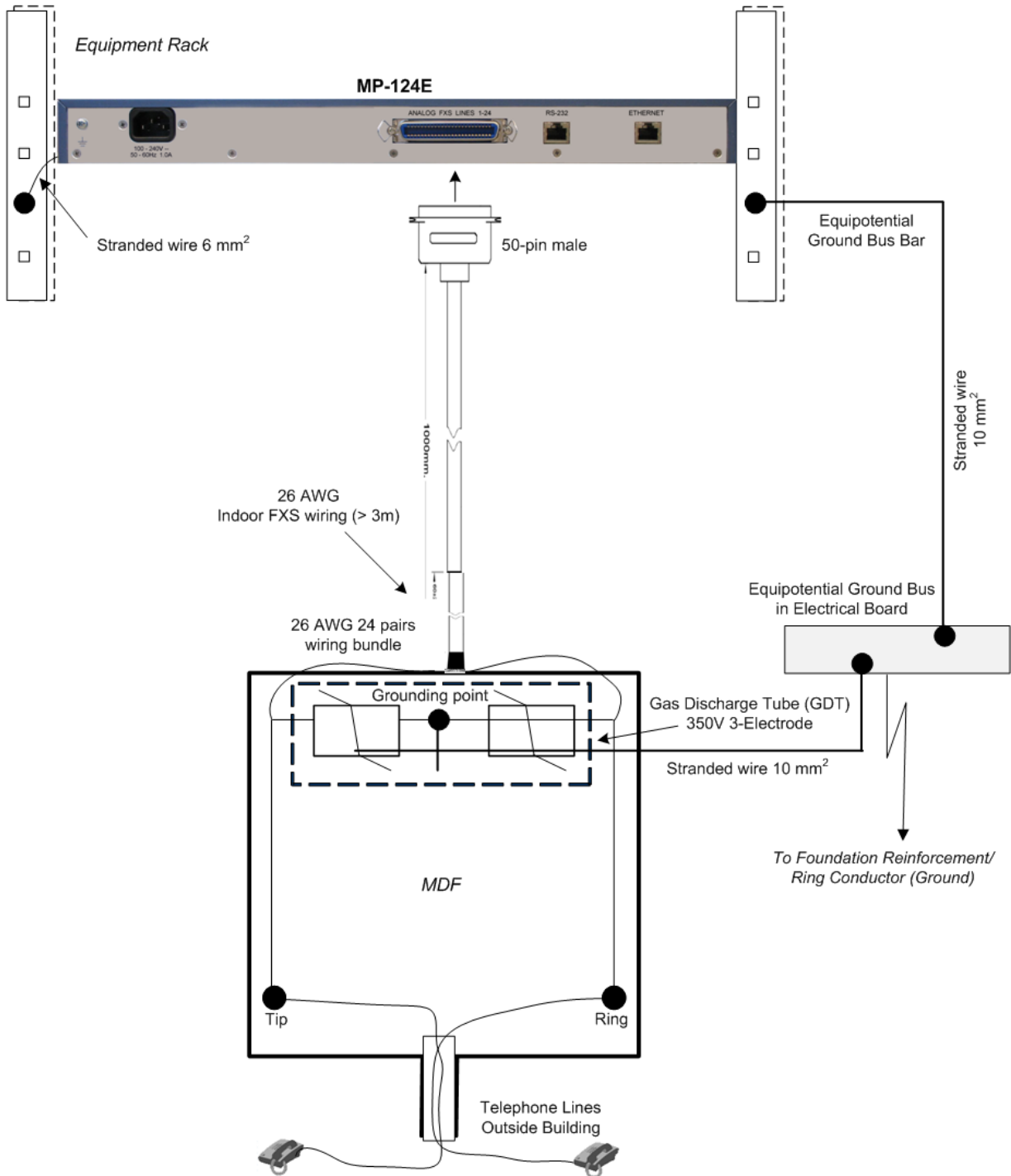

### 5.3.3 Securing Telco Cable to Connector with Velcro Strap

The device interfaces with analog telephone lines by connecting to an MDF using a 50-pin Telco cable, as described in the previous section. If you are using a Centronics cable that is anchored on one side, you can purchase a Velcro Strap Kit from AudioCodes to secure the cable to the device's Telco connector using a Velcro hook-and-loop cable tie (instead of using the connector's bail locks). The kit includes the following items:

- 1 x Bracket
- 1 x Velcro strap
- 2 x Short screws (for DDK cables only)
- 2 x Long screws (all cables except DDK)
- 2 x Hex standoff screws 

The figure below illustrates this Velcro hook-and-loop cable tie:

**Figure 5-10: 50-Pin Telco Cable Secured to Device's Connector using Orderable Velcro Strap**

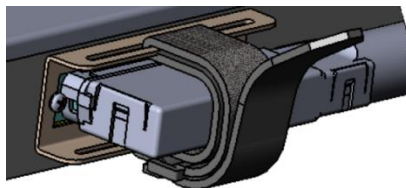

The following procedure describes how to secure Telco cables to the device's Telco connector using a Velcro hook-and-loop cable tie. Before you begin, make sure that you have the following tools:

- Needle-nose pliers
- Philips-head screwdriver
- Flat-head screwdriver
- Hex screwdriver (optional)

➤ **To secure Centronics cable to Telco connector with Velcro hook-and-loop tie:**

1. Using needle-nose pliers, remove the two bail locks located on either side of the device's Telco connector, by squeezing the bail clips together to release it from the connector. Keep the bail locks in a safe place for future use.

**Figure 5-11: Removing Bail Locks from Telco Connector**

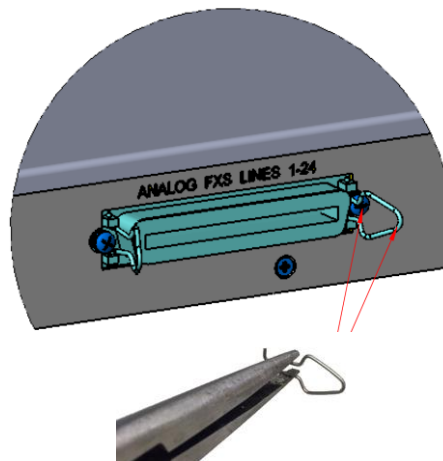

2. Using a Philips-head screwdriver, remove the two screws located on either side of the

connector. Keep the screws in a safe place for future use.

3. Place the supplied bracket over the connector and then fasten it to the chassis using two screws. Depending on your cable connector requirements, use either the Hex. standoff screws, short Philips screws, or long Philips screws.

**Figure 5-12: Attaching Bracket over Telco Connector (e.g., Short Screws)**

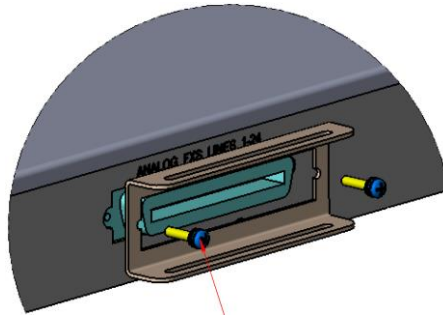

4. Feed the Velcro strap through the two slots of the bracket, from the bottom slot to the top slot, with the Velcro side ("hooks") of the strap facing the chassis. Leave some slack in the strap to allow the Centronics cable connector to slide through it (see next step).

**Figure 5-13: Feeding Velcro Strap through Bracket Slots**

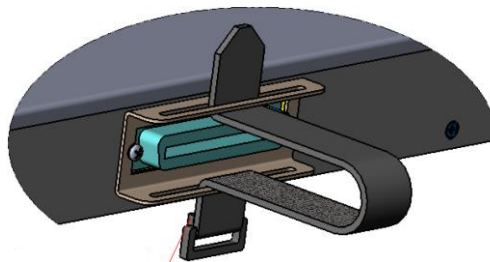

5. Slide the cable connector through the strap, as shown below.

**Figure 5-14: Sliding Cable through Velcro Strap**

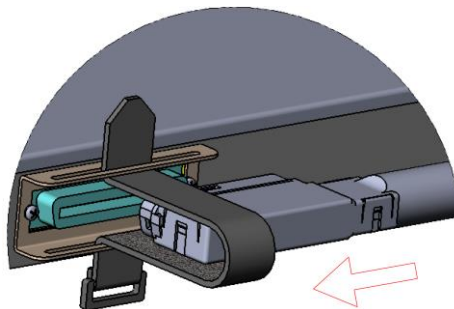

6. Attach the cable connector to the device's Telco connector. A click or snap sound might be heard when the connector is fully seated.

**Figure 5-15: Attaching Cable Connector to Device's Telco Connector**

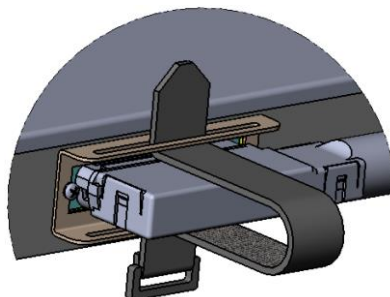

7. Pull the end side (top) of the Velcro strap to eliminate the slack over the cable connector.

**Figure 5-16: Pulling Velcro Strap to Reduce Slack over Cable**

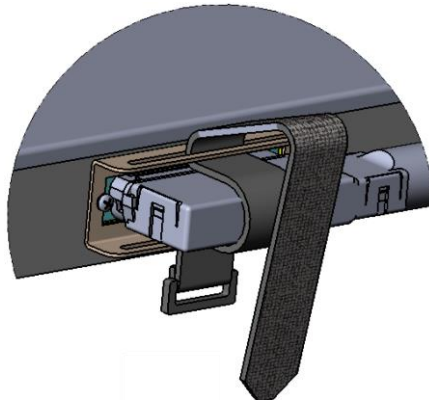

8. Feed the end side of the strap through the strap's buckle.

**Figure 5-17: Feeding Velcro Strap through Strap Buckle**

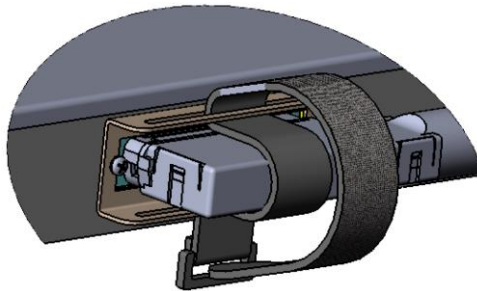

9. Pull the end side of the Velcro strap to eliminate all slack in the strap, and then pull up on the strap and press it firmly on the area of the strap that is already wound around the cable connector so that the strap attaches firmly to itself.

**Figure 5-18: Attaching Velcro Strap to Itself**

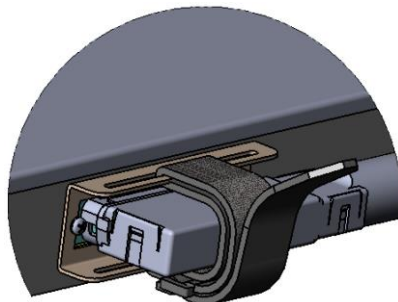

Follow the instructions described in this document to connect AudioCodes Mini Patch Panel to the device, and to the analog FXS lines.

### 5.3.4 Connecting FXS Interfaces using a Mini Patch Panel

You can connect the device's FXS lines to FXS equipment using an AudioCodes orderable Mini Patch Panel.

**Figure 5-19: Mini Patch Panel for FXS Interfaces**



**Safety Notice**

To protect against electrical shock and fire, use 26 AWG minimum wire cabling to connect the Mini Patch Panel and to connect the analog FXS lines.



**Note:**

- The Mini Patch Panel is a separate, customer-ordered item. For more information, contact an AudioCodes sales representative.
- This procedure assumes that the device is securely installed in a 19-inch rack.

➤ **To connect the Mini Patch Panel to the device:**

1. Connect one end of a 25-pair twisted ribbon cable (female) to the female Telco connector on the device's rear panel (labeled **Analog FXS Lines 1-24**), as shown in the figure below.
2. Connect the other end of the 25-pair twisted ribbon cable (female) to the female connector on the Mini Patch Panel (labeled **A**), as shown in the figure below.



3. Connect your analog equipment (for example, fax machines, modems, or telephones) by inserting each RJ-11 connector into the RJ-11 sockets on the front panel of the Mini Patch Panel (as shown in the figure below).

**Figure 5-20: Connecting FXS Lines using Mini Patch Panel**

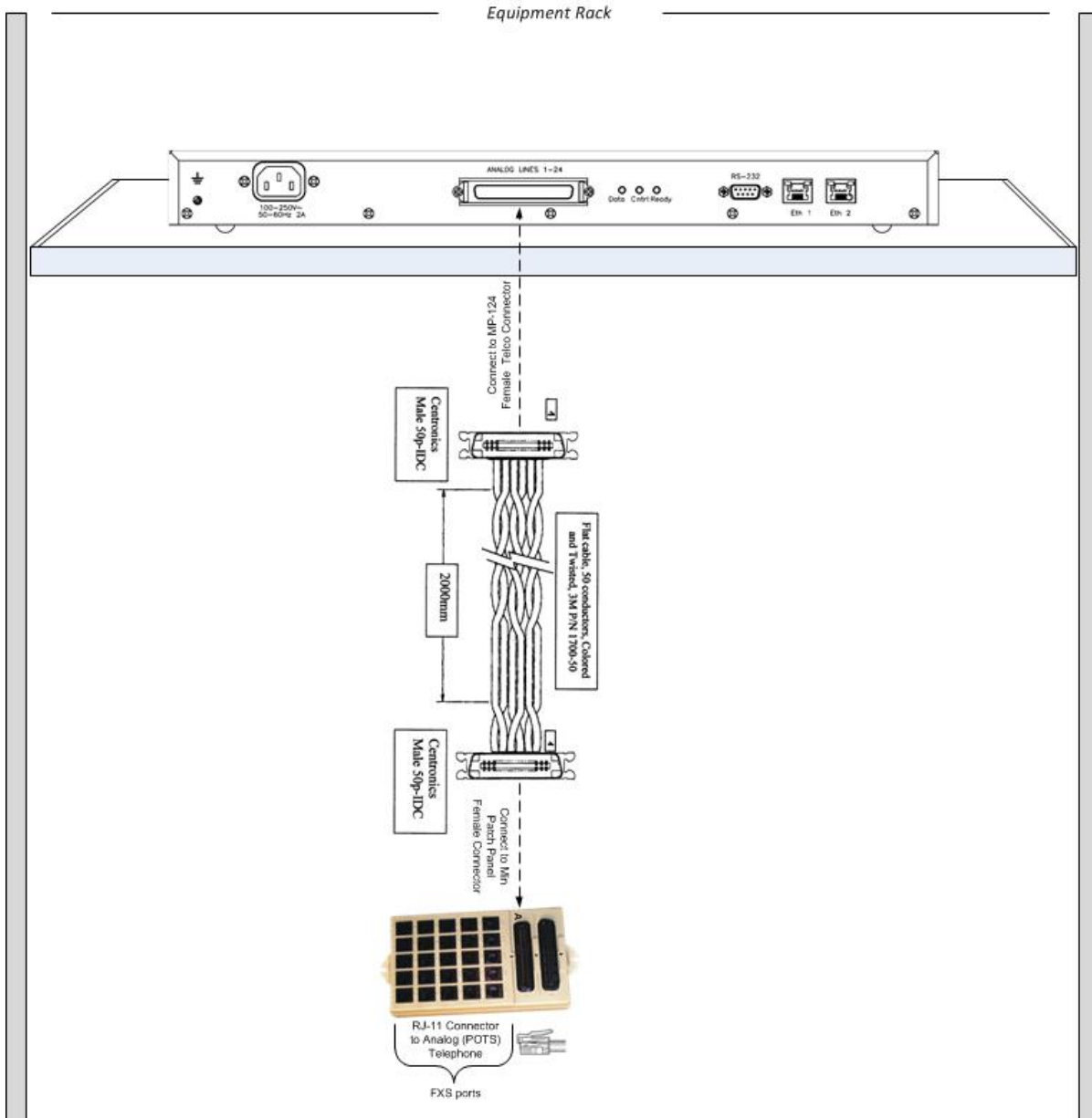

4. Secure the Mini Patch Panel using the provided adhesive stickers or rest it on the rack shelf in a convenient position.

## 5.4 Connecting Device to PC for Serial Communication

The procedure below describes how to connect the device to a computer for serial RS-232 communication. The device provides serial interface through the RJ-45 port located on the rear panel:

- **Cable adapter:** straight-through RJ-45 to DB-9 cable (not supplied)

**Figure 5-21: RJ-45 to DB-9 Serial Cable Adapter**

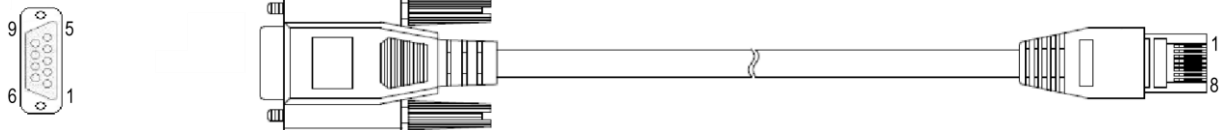

- **Connector pinouts:**

**Table 5-2: RJ-45 to DB-9 Serial Cable Connector Pinouts**

RJ-45	DB-9 Female
1	8
2	6
3	2
4	5
5	5
6	3
7	4
8	7

➤ **To connect the device to a computer for serial communication:**

1. Connect the RJ-45 connector, at one end of the cable adapter, to the device's RJ-45 port labeled **ETHERNET**, located on the rear panel.

**Figure 5-22: Connecting Device for Serial Communication**

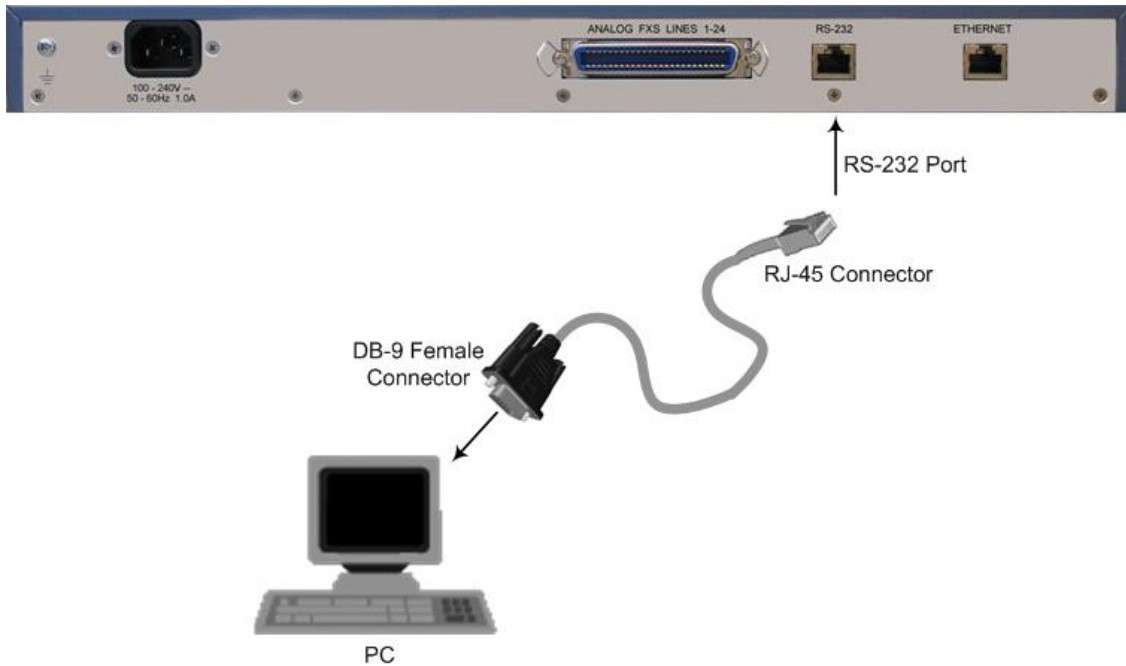

2. Connect the DB-9 connector, at the other end of the cable adapter, to either the COM RS-232 communication port on your computer.

Once you power-up the device, the **Ready** and **LAN** LEDs on the front panel light up green (after a self-testing period of about a minute). Any malfunction in the startup procedure changes the **Ready** LED to red.

## 5.5 Connecting Device to Power

The device can be powered from either a standard AC electrical outlet or a -48V DC power source (depending on ordered model).

**Table 5-3: Power Specifications**

Physical Specification	Description
<b>Power Supply</b>	Single universal power supply
<b>Input Ratings</b>	<ul style="list-style-type: none"> <li>▪ <b>AC:</b> 100-240 VAC, 50-60 Hz, 1A max</li> <li>▪ <b>DC:</b> -48V DC</li> </ul>
<b>Output Ratings</b>	204.7 BTU/hr
<b>Max. Power Consumption</b>	<ul style="list-style-type: none"> <li>▪ 46W: 24 ports @ off-hook long haul</li> <li>▪ 65W: 24 ports @ continuous REN2 ringing</li> </ul>

After powering-up the device, the **Ready** and **Power** LEDs on the front panel light up green (after a self-testing period of about two minutes). Any malfunction in the startup procedure changes the **Fail** LED to red and the **Ready** LED is turned off.

## 5.5.1 AC Power Supply

This section describes how to connect the device to an AC electrical outlet.



### Warnings:

- The device must be connected only by professional service personnel.
- Ensure that the device connects to an electrical socket outlet that provides protective earthing (grounding). Prior to connecting power, refer to the Regulatory Information document supplied with the device.
- Use only a power cord that contains three conductors of 18-AWG minimum wires and that complies and is certified with local electrical code regulation.



### ご注意

本製品に添付の電源ケーブルは、MP-124に専用設計されているため、汎用性はありません。本電源ケーブルを他の機器に使用されないよう、ご注意ください。

### ➤ To connect the device to AC power supply:

1. Connect the line socket of the AC power cord (supplied) to the device's AC power socket, located on the rear panel.

Figure 5-23: Connecting Device to AC Power Supply



2. Connect the plug at the other end of the AC power cord to a standard electrical outlet.

## 5.5.2 DC Power Supply

This section describes how to connect the device to a -48V DC power source.



### DC Safety Notice

When connecting the device to a DC power supply, ensure that you adhere to the following safety guidelines:

- Connection to the -48V mains power must be made only by trained or instructed service personal.
- Connect the device to a safety extra-low voltage (SELV) source that is sufficiently isolated from the mains.
- Connect the device permanently to earth (ground) using the earthing (grounding) stud located on its' rear panel (see 'Power Surge Protection and Grounding Connections' on page 19).

#### ➤ To connect the device to DC power:

1. Insert the two 18-AWG wires into the supplied DC terminal block, ensuring correct polarity (as indicated by the + and - labels located on the rear panel above the DC inlet). Secure the wires by fastening the two integral screws located directly above each wire block.

**Figure 5-24: Inserting DC Wires into DC Terminal Block**

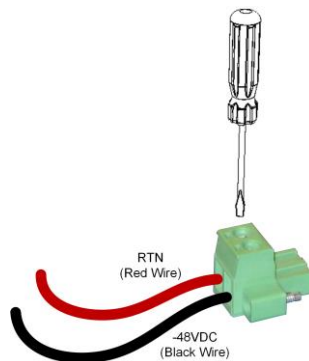

2. Attach the DC terminal block to the DC inlet located on the device's rear panel, and then secure it to the device by fastening the two adaptor-to-panel screws of the terminal block.

**Figure 5-25: Wired DC Power Terminal Block Attached to Device**

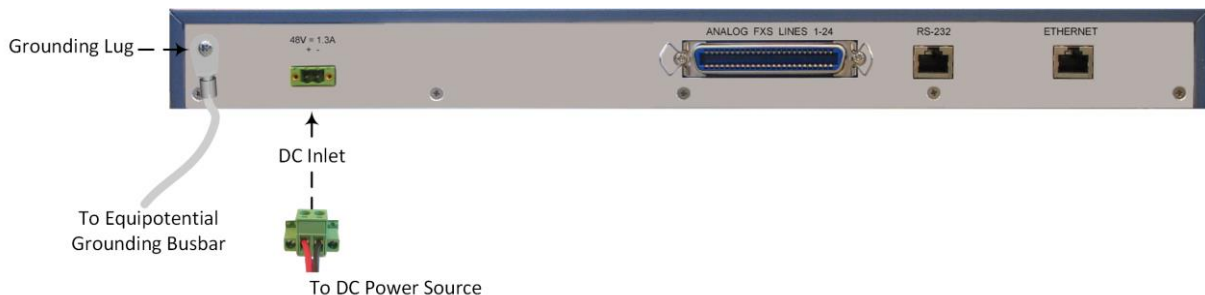

3. Connect the DC power leads to a -48V DC power source. Use a DC rated 5A circuit breaker in series with the -48V wire as a disconnect device.

**This page is intentionally left blank.**

**International Headquarters**

1 Hayarden Street,  
Airport City  
Lod 7019900, Israel  
Tel: +972-3-976-4000  
Fax: +972-3-976-4040

**AudioCodes Inc.**

80 Kingsbridge Rd  
Piscataway, NJ 08854, USA  
Tel: +1-732-469-0880  
Fax: +1-732-469-2298

Contact us: <https://www.audiocodes.com/corporate/offices-worldwide>

Website: <https://www.audiocodes.com>

©2022 AudioCodes Ltd. All rights reserved. AudioCodes, AC, HD VoIP, HD VoIP Sounds Better, IPmedia, Mediant, MediaPack, What's Inside Matters, OSN, SmartTAP, User Management Pack, VMAS, VoIPerfect, VoIPerfectHD, Your Gateway To VoIP, 3GX, VocaNom, AudioCodes One Voice, AudioCodes Meeting Insights, and AudioCodes Room Experience are trademarks or registered trademarks of AudioCodes Limited. All other products or trademarks are property of their respective owners. Product specifications are subject to change without notice.

Document #: LTRT-59853