

## *Provide Switched Relay Contacts when an Analog Phone Line is Down*

The **LVR-1** Line Verification Relay can be used to monitor the service on analog phone lines or extensions. Phone lines can go out of service at any time and without any warning. You could be paying monthly fees for phone lines that are not in service and not realize it. The **LVR-1** can be a real money saver.

The **LVR-1** Line Verification Relay monitors the voltage on an analog phone line. When that voltage goes below 2 volts for a programmable length of time, an onboard relay is activated. When the voltage of the phone line goes above 2 volts for the same programmable length of time, the relay is deactivated. Selectable times are 5, 10, 15 and 20 seconds. By using the timer, the **LVR-1** makes sure that the line is dead before actuating the relay.

The **LVR-1** is powered by an included 12 volt DC power adapter and has either a RJ-11 jack or a terminal block for connection to the phone line.



### Features

- On board 2 pole relay with both NO and NC contacts available
- Phone line connection through a RJ-11 or terminal block
- Power connection through a 2.1 mm plug or terminal block
- Power supply included
- DIP switch selectable delay times of 5, 10, 15, and 20 seconds
- Wall mount housing with (2) #6x3/4 panhead screws included

### Applications

Dead / Disconnected Phone Line Detector for:

- Emergency Phones
- Alarm Systems
- Entry Systems
- Area of Refuge Phones

### Specifications

**Power:** 120V AC/12V DC @ 500mA, UL listed adapter included

**Dimensions:** 4.38" x 2.97" x 1.38" (111mm x 76mm x 36mm)

**Shipping Weight:** 1.06 lbs (.48 kg)

**Environmental:** 32°F to 90°F (0°C to 32°C) with 5% to 95% non-condensing humidity

**Relay Contacts:** 30V DC@1A, 110V DC@0.3A, 125V AC@0.5A

**Trip Point:** 2VDC

**Connections:** (10) cage clamp screw terminals, (1) modular RJ-11 jack

## Features Overview

**!** **IMPORTANT:** Electronic devices are susceptible to lightning and power station electrical surges from both the AC outlet and the telephone line. It is recommended that a surge protector be installed to protect against such surges.

Top View

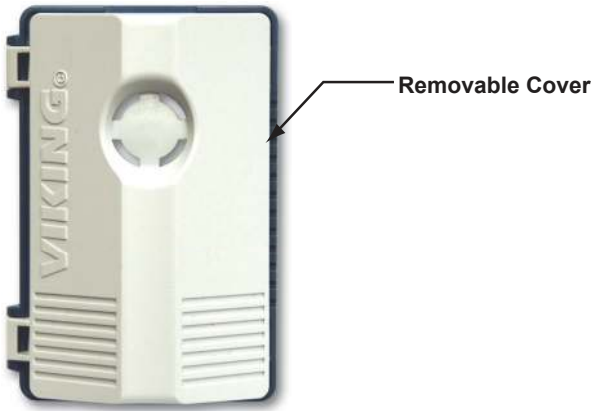

Inside View

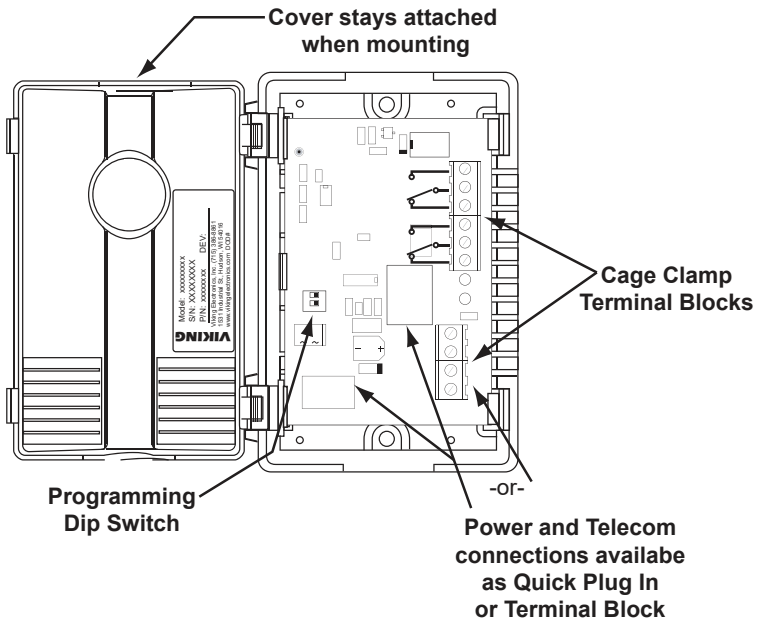

## Installation

The **LVR-1** is designed to mount on a wall using the two #6 screws included with the unit. Below is a diagram showing the two methods that can be used for making connections to the LVR-1. The phone line and power connections are available on either the convenient RJ-11 and 2.1 mm jacks, or the four position terminal block. Relay contact connections are made through a six position terminal block.



**IMPORTANT:** Electronic devices are susceptible to lightning and power station electrical surges from both the AC outlet and the telephone line. It is recommended that a surge protector be installed to protect against such surges.

### Modular Installation

Internal View of the LVR-1

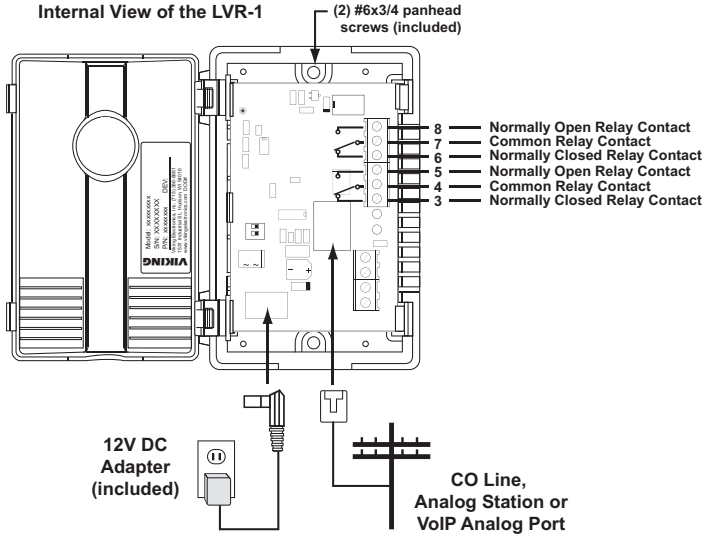

### Hard Wire Installation

Internal View of the LVR-1

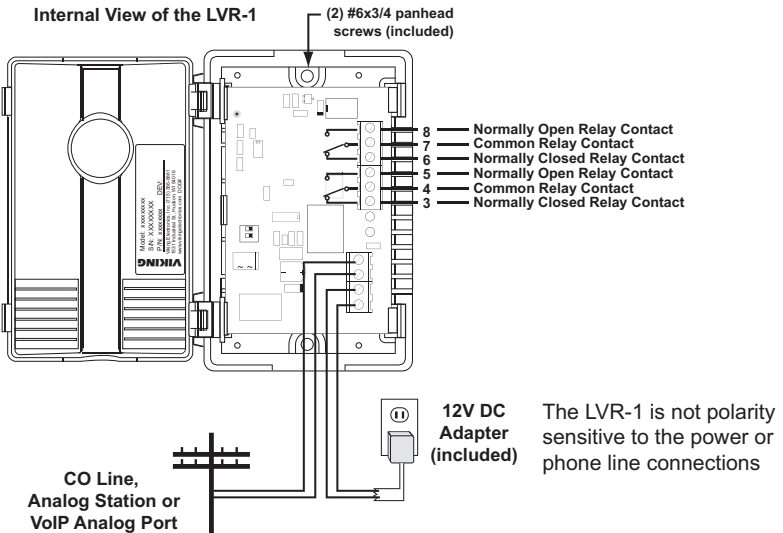

## A. Priority Phone / Entry Device with Backup Phone Line

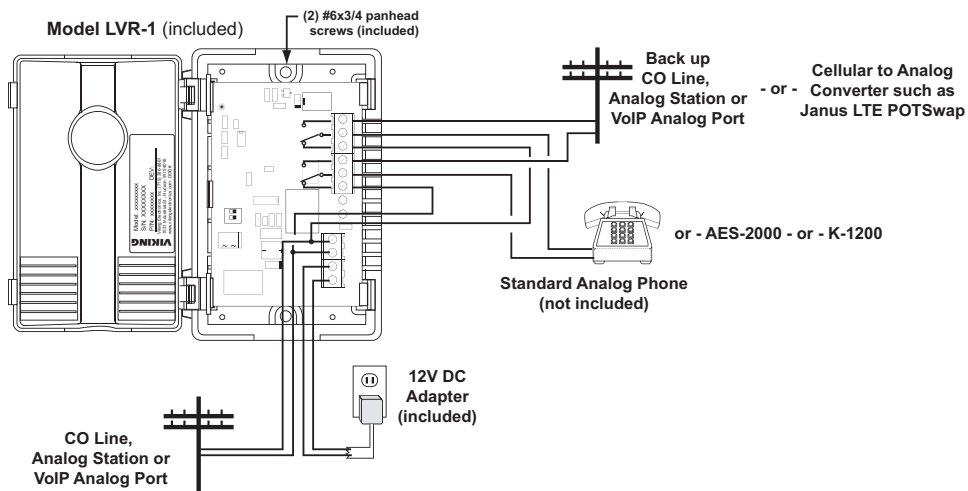

## B. Voice Notification of Dead Phone Line

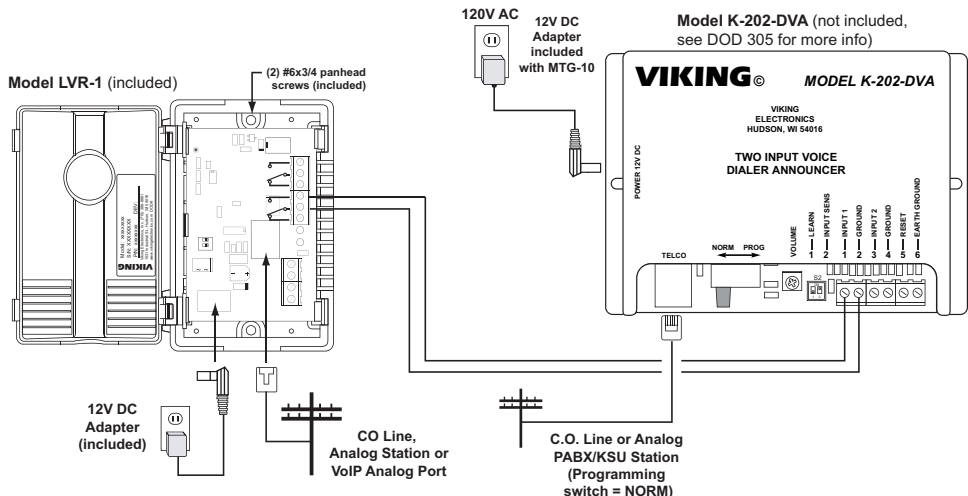

## C. Visual Notification of Dead Phone Line

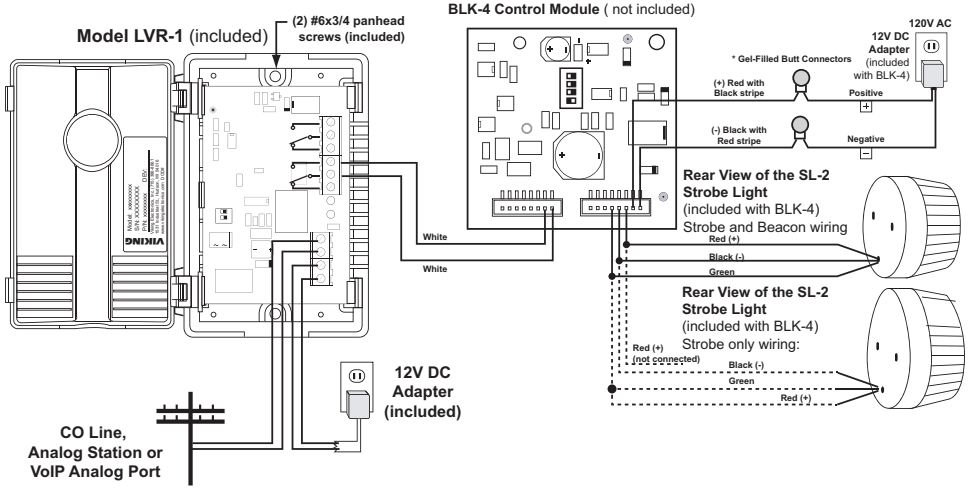

## D. Audible Notification of Dead Phone Line

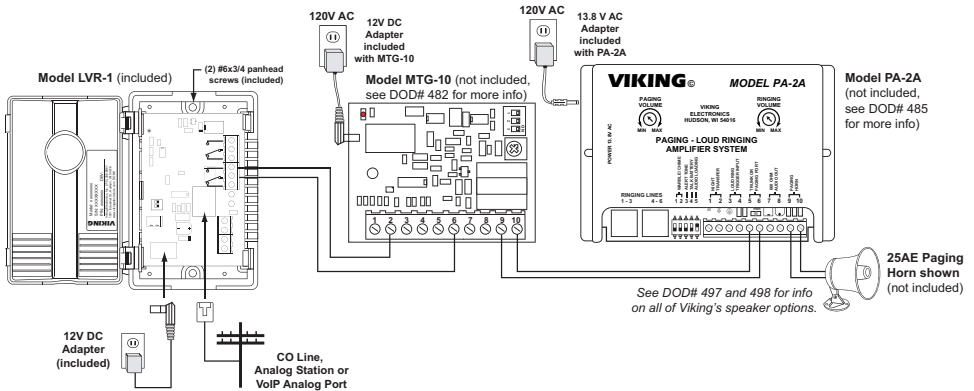

## Programming

The **LVR-1** has two internal DIP switches that allow the user to set the amount of time the phone line is out of service before the relay is actuated. Keep in mind the phone line must be down for the entire Detection Time selected. If the phone service returns before the Detection Time is up, the timer is restarted. Likewise, after the phone service returns, the phone line must be continuously in service for the entire Detection Time selected before the relay is deactivated.

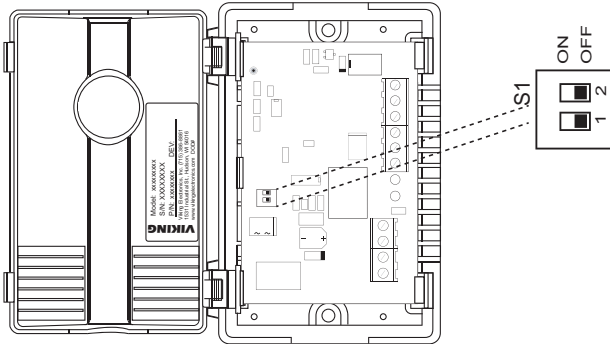

Switch 1	Switch 2	Minimum Detection Time*
OFF	OFF	5 Seconds
ON	OFF	10 Seconds
OFF	ON	15 Seconds
ON	ON	20 Seconds

\* **Note:** The Detection Time when detecting the loss of service is approximate and can increase as much as 15 seconds depending on the type of equipment that is connected to the phone line. When service is restored, the Detection Time is per the DIP switch selection.

## Operation

When connected to a phone line or analog extension, the relay will remain off when the line is idle, ringing or in-use. If the phone line or extension is damaged or there is an equipment failure, the voltage on the line will go below two volts. This starts the Detection Time set by the DIP switches (see Programming). If the phone service does not return before the Detection Time is up, the relay is activated. Once the phone service returns, the phone service must remain until the Detection Time is up before the relay is deactivated.

### ***Provide Line Powered Visual “Ring”, “Off Hook” and Message Waiting Indication***

The Viking model **LPL-1** connects to any standard analog phone line or phone system's analog station port\* to provide visual “Ring” Indication, “On The Phone” indication and “Message Waiting\*\*” indication. The **LPL-1** won't have you guessing which phone is ringing in busy offices. The large flashing LED can be seen up to 100 feet away. When used with a headset on an analog phone, you can end those nagging interruptions that occur when associates don't realize you are on the phone because you are using a headset. The **LPL-1** will light steady indicating to everyone that you are on the phone, flash during ringing or fast flash to indicate message waiting\*\*.

\*Caution: The **LPL-1** is not compatible with digital station ports.

\*\*When installed on phone systems with standard 90VDC message waiting voltage.

**Important:** The **LPL-1** is not designed to recognize stutter dial tone from any analog telephone company line or PABX.



For more Information  
See DOD 640

### ***Provide Line Status and Message Waiting Indication***



For more Information  
See DOD 697

When used with an analog phone line, the **VR-1B** will provide “ring” indication, “on the phone” indication and “message waiting” indication for both “stutter dial tone” and standard message waiting voltage. In this application the **VR-1B** connects directly to tip and ring.

When used with electronic or digital phones, the **VR-1B** won't have you guessing which phone is ringing in busy offices. The flashing LED can be seen up to 100 feet away. The **VR-1B** connects directly to the electronic phone's speaker.

When used with a headset, you can end those nagging interruptions that occur when associates' don't realize you are on the phone because you are using a headset. The **VR-1B** will flash on and off indicating to everyone that you are on the phone and you are not to be disturbed. The **VR-1B** installs in the handset/headset jack using an included “T” adapter.

### ***Add Loud Ringing to Any Analog Phone***



For more Information  
See DOD 477

The **SR-1** will generate loud ringing from an analog ringing line or from a dry contact closure. There are 4 different ringing sounds to choose from. Loudness is easily adjusted with a volume control and test button.

The **SR-1**'s unique sounding rings are useful for employees that often work away from their desks, allowing them to instantly recognize when their phone is ringing. A second set of contact inputs will trigger a door chime (doorbell) sound. This can be used to notify that a door has opened or used as a door bell or push for assistance button.

The **SR-1** is easy to install and comes complete with a power supply and connections for an optional external speaker.

# Warranty

## IF YOU HAVE A PROBLEM WITH A VIKING PRODUCT, CONTACT VIKING TECHNICAL SUPPORT AT: 715-386-8666

Our Technical Support Department is available for assistance Monday to Friday 8:00am - 5:00pm central time. So we can give you better service, before you call please:

1. Know the model number, the serial number, and what software version you have (see serial label).
2. Have the Product Manual in front of you.
3. It is best if you are on site.

### RETURNING PRODUCT FOR REPAIR

The following procedure is for equipment that needs repair:

1. Customer must contact Viking's Technical Support Department at 715-386-8666 to obtain a Return Authorization (RA) number. The customer MUST have a complete description of the problem, with all pertinent information regarding the defect, such as options set, conditions, symptoms, methods to duplicate problem, frequency of failure, etc.
2. Packing: Return equipment in original box or in proper packing so that damage will not occur while in transit. The original product boxes are not designed for shipping - an overpack box is required to prevent damage in transit. Static sensitive equipment such as a circuit board should be in an anti-static bag, sandwiched between foam and individually boxed. All equipment should be wrapped to avoid packing material lodging in or sticking to the equipment. Include ALL parts of the equipment. C.O.D. or freight collect shipments cannot be accepted. Ship cartons prepaid to:

**VIKING ELECTRONICS  
1531 INDUSTRIAL STREET  
HUDSON, WI 54016**

3. Return shipping address: Be sure to include your return shipping address inside the box. We cannot ship to a PO Box.
4. RA number on carton: In large printing, write the RA number on the outside of each carton being returned.

### RETURNING PRODUCT FOR EXCHANGE

The following procedure is for equipment that has failed out-of-box (within 10 days of purchase):

1. Customer must contact Viking's Technical Support at 715-386-8666 to determine possible causes for the problem. The customer MUST be able to step through recommended tests for diagnosis.
2. If the Technical Support Product Specialist determines that the equipment is defective based on the customer's input and troubleshooting, a Return Authorization (RA) number will be issued. This number is valid for fourteen (14) calendar days from the date of issue.
3. After obtaining the RA number, return the approved equipment to your distributor. Please reference the RA number on the paperwork being shipped back with the unit(s), and also the outside of the shipping box. The original product boxes are not designed for shipping - an overpack box is required to prevent damage in transit. Once your distributor receives the package, they will replace the product over the counter at no charge. The distributor will then return the product to Viking using the same RA number.
4. The distributor will NOT exchange this product without first obtaining the RA number from you. If you haven't followed the steps listed in 1, 2 and 3, be aware that you will have to pay a restocking charge.

### TWO YEAR LIMITED WARRANTY

Viking warrants its products to be free from defects in the workmanship or materials, under normal use and service, for a period of two years from the date of purchase from any authorized Viking distributor. If at any time during the warranty period, the product is deemed defective or malfunctions, return the product to Viking Electronics, Inc., 1531 Industrial Street, Hudson, WI., 54016. Customer must contact Viking's Technical Support Department at 715-386-8666 to obtain a Return Authorization (RA) number.

This warranty does not cover any damage to the product due to lightning, over voltage, under voltage, accident, misuse, abuse, negligence or any damage caused by use of the product by the purchaser or others. This warranty does not cover non-EWP products that have been exposed to wet or corrosive environments. This warranty does not cover stainless steel surfaces that have not been properly maintained.

**NO OTHER WARRANTIES, VIKING MAKES NO WARRANTIES RELATING TO ITS PRODUCTS OTHER THAN AS DESCRIBED ABOVE AND DISCLAIMS ANY EXPRESS OR IMPLIED WARRANTIES OR MERCHANTABILITY OR FITNESS FOR ANY PARTICULAR PURPOSE.**

**EXCLUSION OF CONSEQUENTIAL DAMAGES.** VIKING SHALL NOT, UNDER ANY CIRCUMSTANCES, BE LIABLE TO PURCHASER, OR ANY OTHER PARTY, FOR CONSEQUENTIAL, INCIDENTAL, SPECIAL OR EXEMPLARY DAMAGES ARISING OUT OF OR RELATED TO THE SALE OR USE OF THE PRODUCT SOLD HEREUNDER.

**EXCLUSIVE REMEDY AND LIMITATION OF LIABILITY.** WHETHER IN AN ACTION BASED ON CONTRACT, TORT (INCLUDING NEGLIGENCE OR STRICT LIABILITY) OR ANY OTHER LEGAL THEORY, ANY LIABILITY OF VIKING SHALL BE LIMITED TO REPAIR OR REPLACEMENT OF THE PRODUCT, OR AT VIKING'S OPTION, REFUND OF THE PURCHASE PRICE AS THE EXCLUSIVE REMEDY AND ANY LIABILITY OF VIKING SHALL BE SO LIMITED.

IT IS EXPRESSLY UNDERSTOOD AND AGREED THAT EACH AND EVERY PROVISION OF THIS AGREEMENT WHICH PROVIDES FOR DISCLAIMER OF WARRANTIES, EXCLUSION OF CONSEQUENTIAL DAMAGES, AND EXCLUSIVE REMEDY AND LIMITATION OF LIABILITY, ARE SEVERABLE FROM ANY OTHER PROVISION AND EACH PROVISION IS A SEPARABLE AND INDEPENDENT ELEMENT OF RISK ALLOCATION AND IS INTENDED TO BE ENFORCED AS SUCH.

### FCC REQUIREMENTS

This equipment complies with Part 68 of the FCC rules and the requirements adopted by the ACTA. On the side of this equipment is a label that contains, among other information, a product identifier in the format US:AAAEQ#TXXXX. If requested, this number must be provided to the telephone company.

The REN is used to determine the number of devices that may be connected to a telephone line. Excessive REN's on a telephone line may result in the devices not ringing in response to an incoming call. In most but not all areas, the sum of the REN's should not exceed five (5.0). To be certain of the number of devices that may be connected to a line, as determined by the total REN's, contact the local telephone company. For products approved after July 23, 2001, the REN for this product is part of the product identifier that has the format US:AAAEQ#TXXXX. The digits represented by ## are the REN without a decimal point (e.g., 03 is a REN of 0.3). For earlier products, the REN is separately shown on the label.

The plug used to connect this equipment to the premises wiring and telephone network must comply with the applicable FCC Part 68 rules and requirements adopted by the ACTA. If your home has specially wired alarm equipment connected to the telephone line, ensure the installation of this Flvr-1 does not disable your alarm equipment. If you have questions about what will disable alarm equipment, consult your telephone company or a qualified installer.

If the LVR-1 causes harm to the telephone network, the telephone company will notify you in advance that temporary discontinuance of service may be required. But if advance notice isn't practical, the telephone company will notify the customer as soon as possible. Also, you will be advised of your right to file a complaint with the FCC if you believe it is necessary.

The telephone company may make changes in its facilities, equipment, operations, or procedures that could affect the operation of the equipment. If this happens, the telephone company will provide advance notice in order for you to make the necessary modifications to maintain uninterrupted service.

If trouble is experienced with the LVR-1, for repair or warranty information, please contact:

**Viking Electronics, Inc., 1531 Industrial Street, Hudson, WI 54016 (715) 386-8666**

If the equipment is causing harm to the telephone network, the telephone company may request that you disconnect the equipment until the problem is resolved.

Connection to Party Line Service is subject to State Tariffs. Contact the state public utility commission, public service commission or corporation commission for information.

**WHEN PROGRAMMING EMERGENCY NUMBERS AND (OR) MAKING TEST CALLS TO EMERGENCY NUMBERS:**

Remain on the line and briefly explain to the dispatcher the reason for the call. Perform such activities in the off-peak hours, such as early morning or late evenings.

It is recommended that the customer install an AC surge arrester in the AC outlet to which this device is connected. This is to avoid damaging the equipment caused by local lightning strikes and other electrical surges.

### PART 15 LIMITATIONS

This equipment has been tested and found to comply with the limits for a Class A digital device, pursuant to Part 15 of the FCC Rules. These limits are designed to provide reasonable protection against harmful interference when the equipment is operated in a commercial environment. This equipment generates, uses, and can radiate radio frequency energy and, if not installed and used in accordance with the instruction manual, may cause harmful interference to radio communications. Operation of this equipment in a residential area is likely to cause harmful interference in which case the user will be required to correct the interference at his own expense.

## Product Support: 715-386-8666

Due to the dynamic nature of the product design, the information contained in this document is subject to change without notice. Viking Electronics, and its affiliates and/or subsidiaries assume no responsibility for errors and omissions contained in this information. Revisions of this document or new editions of it may be issued to incorporate such changes.