

Emergency Phone Panic Button Kit

(for use with Viking Emergency Phones)

The **PB-1** Panic Button Kit connects to a Viking **1600A** or **1600-IP Series** Emergency Phone to provide a one-way talk path to the pre-programmed number when used.

The **PB-1** will activate the **1600A** or **1600-IP Series** Emergency Phone and allows the called party to light a red LED to indicate that the call is connected. The called party will be able to hear the installation site, but the site will not be able to hear the called party. This makes



it a very effective security measure, as there is no other indication that the site is being monitored.

Features

- LED to indicate call connected
- One-way talk path for listening without audible indication
- Unobtrusive - mount anywhere at any angle with supplied foam tape
- Provides security and peace of mind
- Switch can be used to trigger inputs on **K-2000-DVA**, **K-202-DVA**, **SLP-1**, **SLP-4**, etc.

Applications

- Courtrooms
- Bank tellers
- Gas stations
- Motel reception desks
- All night restaurants
- Convenience stores

Specifications

Dimensions: 65mm x 35mm x 20mm (2.56" x 1.38" x 0.79")

Shipping Weight: 0.05kg (0.1 lbs)

Environmental: 0°C to 32°C (32°F to 90°F) with 5% to 95% noncondensing humidity

Cord Length: 7 ft

Connections: (1) RJ11 jack, (1) 10-position JST connector, (6) gel-filled butt connectors

www.vikingelectronics.com
Information: (715) 386-8861

A. Connecting to a Viking 1600A Series Analog Emergency Phone

Step 1.	Mount the PB-1 using the supplied foam tape.
Step 2.	Connect the RJ11 plug on the supplied cable to the PB-1 .
Step 3.	Disconnect the installed white connector from the 1600A Series Emergency Phone board .
Step 4.	Remove the 1600A Series Emergency Phone board and then remove the installed mic by carefully pulling it out of the black plastic mic mount.
Step 5.	Place the mic from the PB-1 cable into the mic mount and replace the 1600A Series Emergency Phone board .
Step 6.	Connect the white connector on the PB-1 cable to the 1600A Series phone board .
Step 7.	Connect the phone line to the red and green wires from the 1600A Series Emergency Phone board .

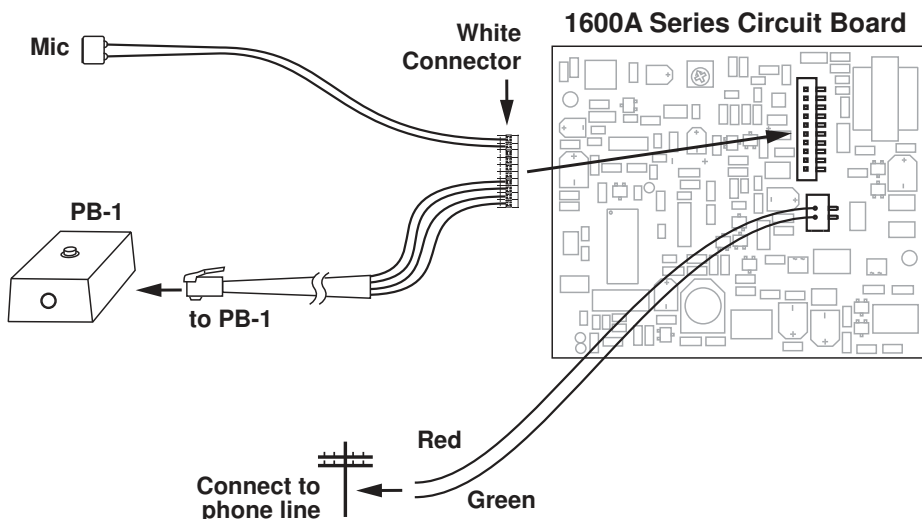

B. Connecting to a Viking 1600A-EWP Series Analog Emergency Phone

Step 1.	Mount the PB-1 using the supplied foam tape.
Step 2.	Connect the RJ11 plug on the supplied cable to the PB-1 .
Step 3.	Cut the PB-1 cable at the white connector, discard the connector and mic.
Step 4.	Cut the black and red wires leading to the LED from the 1600A Series board, leaving at least 1 inch of wire at the connector.
Step 5.	Attach the black wire from the board to the black wire from the PB-1 using a gel-filled butt connector (do not strip prior to inserting).
Step 6.	Attach the red wire from the board to the yellow wire from the PB-1 .
Step 7.	Cut the two black wires leading to the switch from the 1600A Series board, leaving at least 1 inch of wire at the connector.
Step 8.	Attach one black wire to the red wire, and one to the green wire from the PB-1 (non-polarity sensitive).
Step 9.	Cut the two white wires leading to the speaker from the 1600A board.
Step 10.	Connect the phone line to the red and green wires from the PCB.

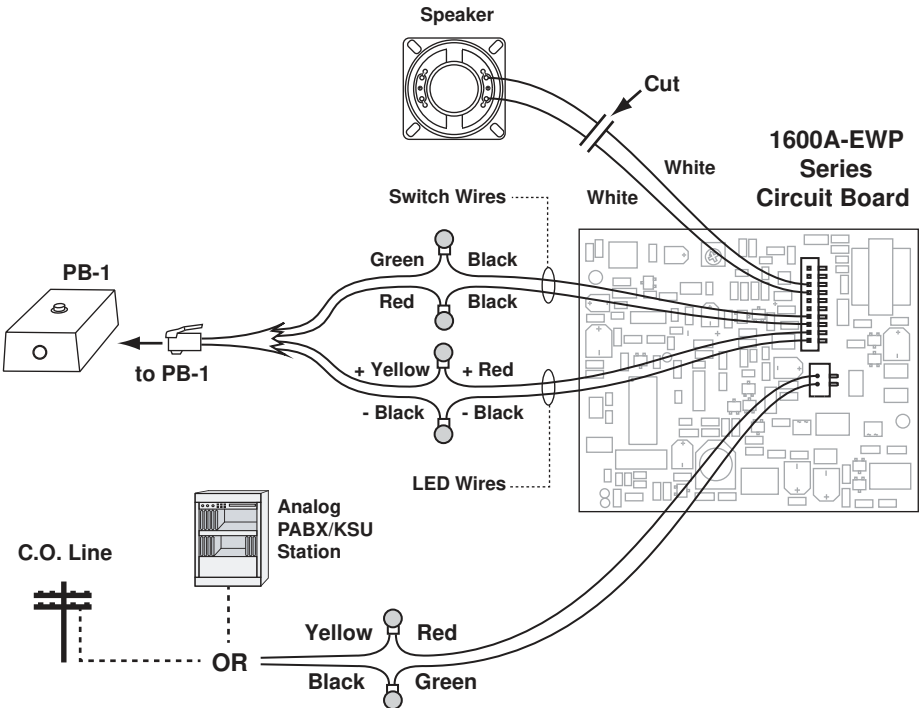

C. Connecting to a Viking 1600-IP Series VoIP Emergency Phone

Step 1.	Mount the PB-1 using the supplied foam tape.
Step 2.	Connect the RJ11 plug on the supplied cable to the PB-1 .
Step 3.	Disconnect the installed white connector from the 1600-IP Series Emergency Phone board .
Step 4.	Remove the 1600-IP Series Emergency Phone board and then remove the installed mic by carefully pulling it out of the black plastic mic mount.
Step 5.	Place the mic from the PB-1 cable into the mic mount and replace the 1600-IP Series Emergency Phone board .
Step 6.	Connect the white connector on the PB-1 cable to the 1600-IP Series phone board .
Step 7.	Connect the LAN with PoE cable to the RJ-45 jack.

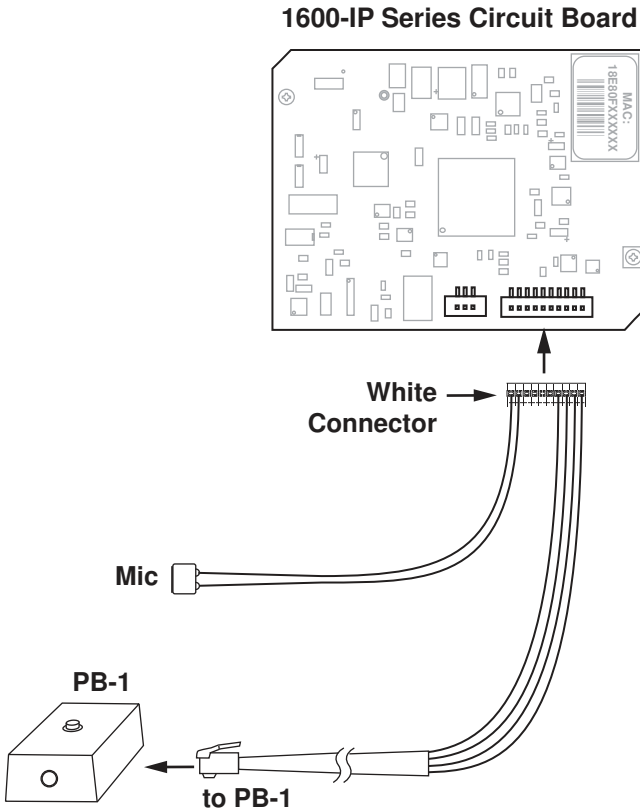

D. Connecting to a Viking 1600-IP-EWP Series VoIP Emergency Phone

Step 1.	Mount the PB-1 using the supplied foam tape.
Step 2.	Connect the RJ11 plug on the supplied cable to the PB-1 .
Step 3.	Cut the PB-1 cable at the white connector, discard the connector and mic.
Step 4.	Cut the black and red wires leading to the LED from the 1600-IP Series board, leaving at least 1 inch of wire at the connector.
Step 5.	Attach the black wire from the board to the black wire from the PB-1 using a gel-filled butt connector (do not strip prior to inserting).
Step 6.	Attach the red wire from the board to the yellow wire from the PB-1 .
Step 7.	Cut the two black wires leading to the switch from the 1600-IP Series board, leaving at least 1 inch of wire at the connector.
Step 8.	Attach one black wire to the red wire, and one to the green wire from the PB-1 (non-polarity sensitive).
Step 9.	Turn speaker mode to Off/Silent Monitor in IP Programming. See the 1600-IP Series Product Manual, DOD# 255 .
Step 10.	Connect the LAN with PoE cable to the RJ-45 jack.

1600-IP-EWP Series Circuit Board

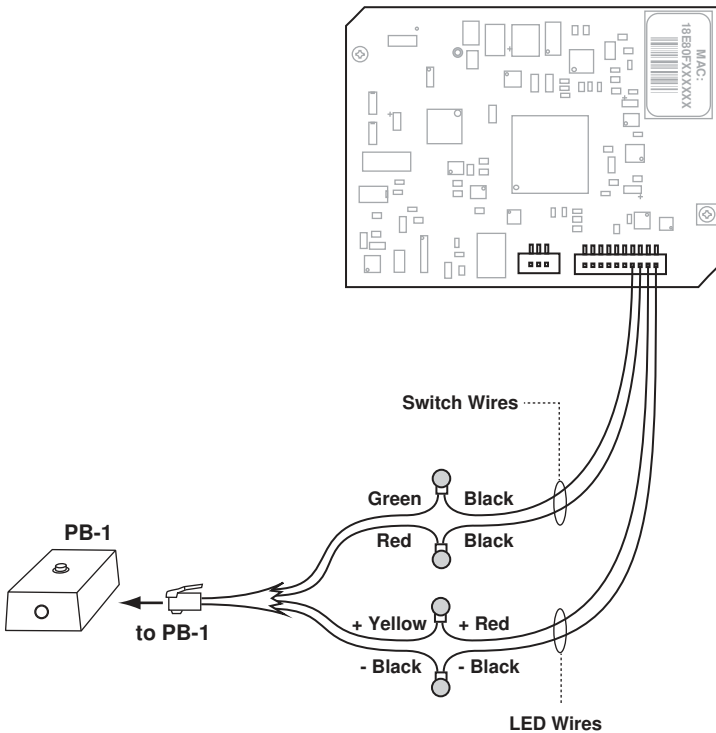

E. Switch Only Applications (K-2000-DVA, K-202-DVA, SLP-1 or SLP-4)

Step 1.	Mount the PB-1 using the supplied foam tape.
Step 2.	Connect the RJ11 plug on the supplied cable to the PB-1 .
Step 3.	Cut the PB-1 cable at the white connector, discarding the connector and mic.
Step 4.	Connect the red and green wires to the contact terminals on the product (non-polarity sensitive).

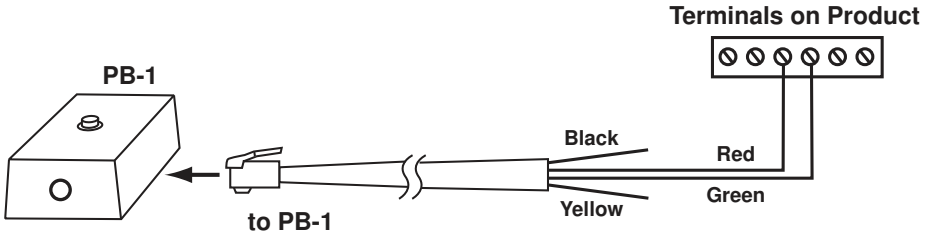

Programming the E-1600A Series Analog Emergency Phone

IMPORTANT: Use the information below in conjunction with the **1600A Series Technical Practice (DOD# 215)**.

A. Recommended DIP Switch Settings

Switch	Position	Description
1	OFF	Disable hang-up with the "Call" button*
2	ON	Enable answering of incoming calls
3	ON	Normal operation mode

B. Accessing the Programming Mode

Step 1.	Move DIP switch 2 to the ON position (sets unit to answer incoming calls).
Step 2.	Move DIP switch 3 to the OFF position (incoming calls enter Programming without security code).
Step 3.	From a touch tone phone call the line attached to the 1600A Series phone.
Step 4.	When the 1600A Series , a double beep will be heard and the unit will enter the programming mode.
Step 5.	When finished programming, move DIP switch 3 back to the ON position.

C. Touch Tone Programming

Enter Digits	Enter Programming Location	Description
0-20 digits	#00 - #05	Up to 5 emergency speed dial numbers.
000210	#17	Play message on answer, dial "*" to stop message and light LED on PB-1 .
100321	#18	0.1 second VOX time, no call length or silence time out, dial next number on ring-no-answer (3 rings) and busy signal, 10pps pulse dialing speed.

D. Recording a Message

Make a recording (*4) including the following details:

1. Location of the emergency phone
2. One way talk path (listen only)
3. Press * to stop this message and indicate that the call is connected

Warranty

IF YOU HAVE A PROBLEM WITH A VIKING PRODUCT, CONTACT: VIKING TECHNICAL SUPPORT AT (715) 386-8666

Our Technical Support Department is available for assistance Monday 8am - 4pm and Tuesday through Friday 8am - 5pm central time. So that we can give you better service, before you call please:

1. Know the model number, the serial number and what software version you have (see serial label).
2. Have your Product Manual in front of you.
3. It is best if you are on site.

RETURNING PRODUCT FOR REPAIR

The following procedure is for equipment that needs repair:

1. Customer must contact Viking's Technical Support Department at 715-386-8666 to obtain a Return Authorization (RA) number. The customer **MUST** have a complete description of the problem, with all pertinent information regarding the defect, such as options set, conditions, symptoms, methods to duplicate problem, frequency of failure, etc.
2. Packing: Return equipment in original box or in proper packing so that damage will not occur while in transit. Static sensitive equipment such as a circuit board should be in an anti-static bag, sandwiched between foam and individually boxed. All equipment should be wrapped to avoid packing material lodging in or sticking to the equipment. Include ALL parts of the equipment. C.O.D. or freight collect shipments cannot be accepted. Ship cartons prepaid to: **Viking Electronics, 1531 Industrial Street, Hudson, WI 54016**
3. Return shipping address: Be sure to include your return shipping address inside the box. We cannot ship to a PO Box.
4. RA number on carton: In large printing, write the R.A. number on the outside of each carton being returned.

RETURNING PRODUCT FOR EXCHANGE

The following procedure is for equipment that has failed out-of-box (within 10 days of purchase):

1. Customer must contact Viking's Technical Support at 715-386-8666 to determine possible causes for the problem. The customer **MUST** be able to step through recommended tests for diagnosis.
2. If the Technical Support Product Specialist determines that the equipment is defective based on the customer's input and troubleshooting, a Return Authorization (R.A.) number will be issued. This number is valid for fourteen (14) calendar days from the date of issue.
3. After obtaining the R.A. number, return the approved equipment to your distributor, referencing the R.A. number. Your distributor will then replace the Viking product using the same R.A. number.
4. **The distributor will NOT exchange this product without first obtaining the R.A. number from you. If you haven't followed the steps listed in 1, 2 and 3, be aware that you will have to pay a restocking charge.**

TWO YEAR LIMITED WARRANTY

Viking warrants its products to be free from defects in the workmanship or materials, under normal use and service, for a period of two years from the date of purchase from any authorized Viking distributor. If at any time during the warranty period, the product is deemed defective or malfunctions, return the product to Viking Electronics, Inc., 1531 Industrial Street, Hudson, WI., 54016. Customer must contact Viking's Technical Support Department at 715-386-8666 to obtain a Return Authorization (R.A.) number.

This warranty does not cover any damage to the product due to lightning, over voltage, under voltage, accident, misuse, abuse, negligence or any damage caused by use of the product by the purchaser or others. This warranty does not cover non-EWP products that have been exposed to wet or corrosive environments. This warranty does not cover stainless steel surfaces that have not been properly maintained.

NO OTHER WARRANTIES: VIKING MAKES NO WARRANTIES RELATING TO ITS PRODUCTS OTHER THAN AS DESCRIBED ABOVE AND DISCLAIMS ANY EXPRESS OR IMPLIED WARRANTIES OR MERCHANTABILITY OR FITNESS FOR ANY PARTICULAR PURPOSE.

EXCLUSION OF CONSEQUENTIAL DAMAGES: VIKING SHALL NOT, UNDER ANY CIRCUMSTANCES, BE LIABLE TO PURCHASER, OR ANY OTHER PARTY, FOR CONSEQUENTIAL, INCIDENTAL, SPECIAL OR EXEMPLARY DAMAGES ARISING OUT OF OR RELATED TO THE SALE OR USE OF THE PRODUCT SOLD HEREUNDER.

EXCLUSIVE REMEDY AND LIMITATION OF LIABILITY: WHETHER IN AN ACTION BASED ON CONTRACT, TORT (INCLUDING NEGLIGENCE OR STRICT LIABILITY) OR ANY OTHER LEGAL THEORY, ANY LIABILITY OF VIKING SHALL BE LIMITED TO REPAIR OR REPLACEMENT OF THE PRODUCT, OR AT VIKING'S OPTION, REFUND OF THE PURCHASE PRICE AS THE EXCLUSIVE REMEDY AND ANY LIABILITY OF VIKING SHALL BE SO LIMITED.

IT IS EXPRESSLY UNDERSTOOD AND AGREED THAT EACH AND EVERY PROVISION OF THIS AGREEMENT WHICH PROVIDES FOR DISCLAIMER OF WARRANTIES, EXCLUSION OF CONSEQUENTIAL DAMAGES, AND EXCLUSIVE REMEDY AND LIMITATION OF LIABILITY, ARE SEVERABLE FROM ANY OTHER PROVISION AND EACH PROVISION IS A SEPARABLE AND INDEPENDENT ELEMENT OF RISK ALLOCATION AND IS INTENDED TO BE ENFORCED AS SUCH.

Product Support: (715) 386-8666

Due to the dynamic nature of the product design, the information contained in this document is subject to change without notice. Viking Electronics, and its affiliates and/or subsidiaries assume no responsibility for errors and omissions contained in this information. Revisions of this document or new editions of it may be issued to incorporate such changes.