

VIP-4122-D44-IC InformaCast® Compliant IP LAY-IN SPEAKER / DIGITAL CLOCK COMBO

INTRODUCTION

The VIP-4122-D44-IC InformaCast Compliant IP Clock with Speaker includes a 4" Digital Clock and a 2' x 2' Lay-in Talkback Ceiling Speaker. This provides synchronized time, talkback intercom and loudspeaker paging from one IP network connection. The 4-digit Digital Clock will sync its time with the InformaCast Server. The clock and speaker enclosures are made of steel with a durable powder coated finish. The color of the enclosures can be easily changed to match any décor. Power is provided to both the clock and speaker via a Power over Ethernet (PoE) switch meeting the 802.3af specification.

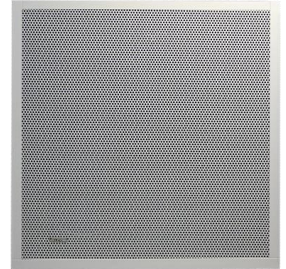

SPECIFICATIONS

Features

- Only one network connection required
- Easy to read, high visibility Red digits display hours and minutes (4-digit display)
- Power over Ethernet (PoE) 802.3af compatible
- High Efficiency

Dimensions / Weight

- Clock - 17.00" L x 3.00" W x 6.75" H
(43.2 cm) x (7.6 cm) x (17.1 cm)
Weight: 5.1 lbs. (2.0 kg)
- Speaker - 23.75" L x 23.75" W x 3.75" D
(60.3 cm) x (60.3 cm) x (9.5 cm)
Weight: 5.5 lbs. (2.5 kg)

Nominal Power Requirements

Via 802.3af PoE Ethernet Switch: Class 3

Environment

Temperature: 0 to +40° C
Humidity: 0 to 85% non-precipitating

Precautionary Designations

- **WARNING: To Reduce The Risk Of Fire Or Electric Shock. Do Not Expose This Apparatus To Rain Or Moisture.**
- **AVERTISSEMENT: Afin de réduire les risques d'incendie ou de décharge électrique, évitez d'exposer le système à la pluie ou à l'humidité.**
- **Apparatus shall not be exposed to dripping or splashing and no objects filled with liquids, such as vases, shall be placed on the apparatus.**
- **L'appareil ne doit pas être exposé à des égouttements et éclaboussures et aucun Objet Rempli de liquide, comme vase, ne doit être placé sur l'appareil.**

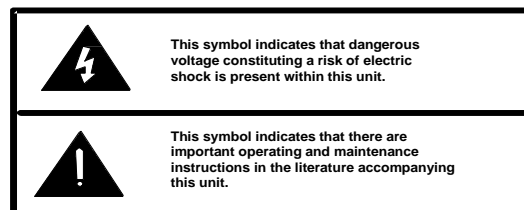
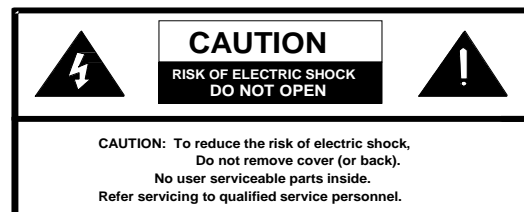

IMPORTANT SAFETY INFORMATION

CONSIGNES DE SÉCURITÉ IMPORTANTES

1. Read these instructions.
Lisez ces instructions.
2. Keep these instructions.
Conservez ces instructions.
3. Heed all warnings.
Respectez tous les avertissements.
4. Follow all instructions.
Suivez toutes les instructions.
5. Do not use this apparatus near water.
Ne pas utiliser cet appareil près de l'eau.
6. Clean only with dry cloth.
Nettoyer avec un chiffon sec.
7. Do not block any ventilation openings. Install in accordance with the manufacturer's instructions.
Ne pas bloquer les ouvertures de ventilation. Installer conformément aux instructions du fabricant.
8. Do not install near any heat sources such as radiators, heat registers, stoves or other apparatus (including amplifiers) that produce heat.
Ne pas installer à proximité de sources de chaleur telles que radiateurs, registres de chaleur, poêles ou autres appareils (y compris les amplificateurs) produisant de la chaleur.
9. Do not defeat the safety purpose of the polarized or grounding-type plug. A polarized plug has two blades with one wider than the other. A grounding type plug has two blades and a third grounding prong. The wide blade and the third prong are provided for your safety. If the provided plug does not fit into your outlet consult an electrician for replacement of the obsolete outlet.
Ne pas contourner le dispositif de sécurité de la fiche polarisée ou de mise à la terre. Une fiche polarisée possède deux lames dont une plus large que l'autre. Une fiche de terre a deux lames et une troisième broche de mise à la terre. La lame large et la troisième broche sont fournies pour votre sécurité. Si la fiche fournie ne rentre pas dans votre prise, veuillez consulter un électricien pour le remplacement de la prise obsolète.
10. Protect the power cord from being walked on or pinched particularly at plugs, convenience receptacles and the point where they exit from the apparatus.
11. Only use attachments/accessories specified by the manufacturer.
N'utilisez que des fixations / accessoires spécifiés par le fabricant.
12. Use only with the cart, stand, tripod, bracket or table specified by the manufacturer or sold with the apparatus. When a cart is used, use caution when moving the cart/apparatus combination to avoid injury from tip-over.
Utilisez uniquement avec le chariot, stand, trépied, support ou table spécifié par le fabricant ou vendu avec l'appareil. Quand un chariot est utilisé, Soyez prudent lorsque vous déplacez l'ensemble chariot / appareil pour éviter des blessures dues au renversement.
13. Unplug this apparatus during lightning storms or when unused for a long period of time.
Débranchez cet appareil pendant les orages ou lorsqu'il n'est pas utilisé pendant une longue période de temps.
14. Refer all servicing to qualified service personnel. Servicing is required when the apparatus has been damaged in any way. Such as when the power supply cord or plug is damaged, liquid has been spilled, objects have fallen into the apparatus or the apparatus has been exposed to rain or moisture and does not operate normally or has been dropped.
Confiez toute réparation à un personnel qualifié. Une réparation est nécessaire lorsque l'appareil a été endommagé de quelque façon. Par exemple lorsque le cordon d'alimentation ou la fiche est endommagé, du liquide a été renversé, si des objets sont tombés dans l'appareil ou le appareil a été exposé à la pluie ou à l'humidité et ne fonctionne pas normalement ou s'il est tombé.



INSTALLATION

FCC Information

This equipment has been tested and found to comply with the limits for a Class A digital device, pursuant to Part 15 of the FCC Rules. These limits are designed to provide reasonable protection against harmful interference when the equipment is operated in a commercial environment. This equipment generates, uses and can radiate radio frequency energy and if not installed and used in accordance with the instruction manual, may cause harmful interference to radio communications. Operation of this equipment in a residential area may cause harmful interference in which case the user will be required to correct the interference at one's own expense.

Speaker Mounting

The 2'x2' Lay-in Speaker is designed to replace ½ of a standard 2'x4' ceiling tile.

Speaker Connections

Connect the attached wire assembly from the Lay-in Speaker to the Speaker screw connections on the clock circuit board. (Figure 1)

Clock Mounting

Remove the side screws holding the mounting plate/rear panel to the enclosure. Mount the plate to the wall or a standard double-gang electrical box using appropriate hardware such as #8 pan head screws (not supplied). After making the required speaker wiring and network connections, reattach the enclosure to the mounting plate/rear panel. (Figure 2)

Network Connection

The VIP-4122-D44-IC has one RJ-45 network connector on the rear panel. Connect a standard Ethernet patch cable from the VIP-4122-D44-IC into an Ethernet switch. If a PoE switch is not available, a PoE mid-span injector may be used to supply power to the clock and speaker. (Figure 1)

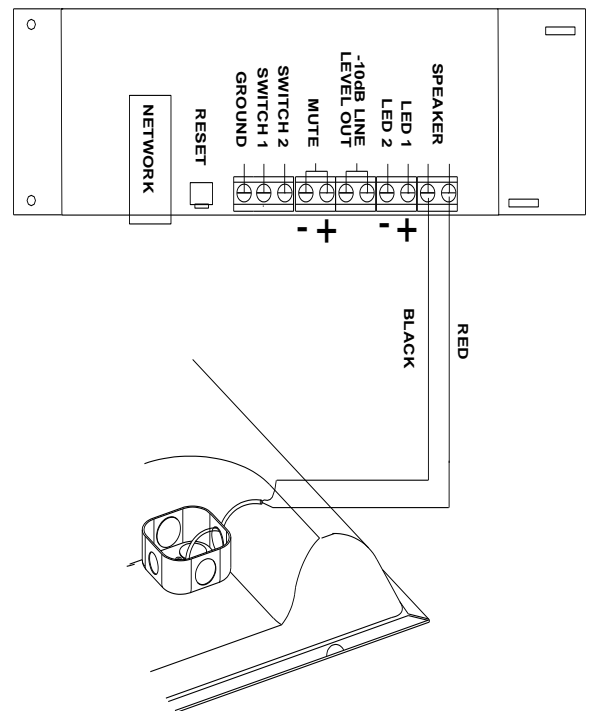

Figure 1. IP Clock/Speaker Connections

Call Switch Connection

For IP Speakers using Talkback functionality, a call switch input via screw terminals is provided. Connect a momentary contact switch to Switch 1 and Ground.

-10 dB Line Level Out Connection

The -10dBm Line Level Out may be connected to up to 40 Valcom Self Amplified Speakers in order to provide additional sound reinforcement in an area.

LED 1 and LED 2 Connection

LED 1 (+) and LED 2 (-) is a current limited output designed to illuminate an optional LED. The LED is intended to provide visual indication of call progress. The LED illumination will flash when the call switch is pressed and will continue to flash until the call is answered. The LED illumination will be solid when a connection to the unit is established.

SETUP

The VIP-4122-D44-IC will automatically acquire an IP address (using DHCP) and connect to the InformaCast server when connected to the network and powered up. Information specific to your application will need to be programmed into the InformaCast server. Refer to the InformaCast documentation for further information.

TECHNICAL ASSISTANCE

When trouble is reported, verify power is being supplied to the unit and there are no broken connections. If a spare unit is available, substitute a spare unit for the suspected defective unit.

Assistance in troubleshooting is available from the factory. Call (540) 563-2000 and press 1 for Valcom Technical Support or visit our website at www.valcom.com.

Valcom equipment is not field-repairable. Valcom, Inc. maintains service facilities in Roanoke, VA. Should repairs be necessary, attach a tag to the unit clearly stating your company name, address, phone number, contact person and the nature of the problem. Send the unit to:

Valcom, Inc.
Repair & Return Dept.
5614 Hollins Road
Roanoke, Va. 24019-5056

WARRANTY

Warranty information may be found on our website at www.valcom.com/warranty.

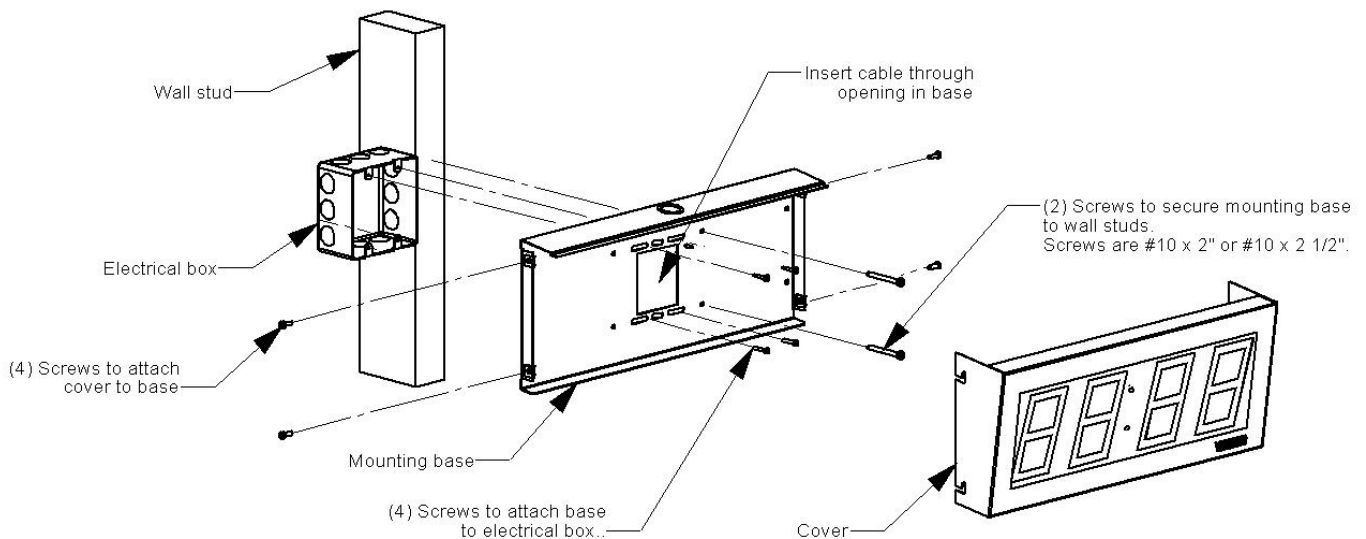

Figure 2. Clock Mounting