

Convert Any 8 Ohm, 25V or 70V Analog Paging Speaker to an IP Speaker for SIP Endpoint Paging and/or Multicast Paging

The **PSA-IP** Speaker Adapter enables you to quickly convert any 8 Ohm, 25V or 70V analog paging speaker into a SIP endpoint paging speaker. After the quick conversion, the speaker can then be used for standard one-way SIP endpoint paging or multicast paging.

The compact chassis of the **PSA-IP** can be mounted magnetically to the back of an analog speaker magnet, or use the included screws to attach the unit to the 25/70V transformer mounting holes on the speaker frame. Installation is easy - attach the wires, and then connect a CAT5/6 cable from your PoE switch.

The **PSA-IP** features a high-efficiency 6 Watt class D amplifier capable of driving up to six 8 Ohm analog paging speakers. This allows a single **PSA-IP** to cover up to six speaker paging zones with approximately 1 Watt of paging power per speaker.



Typical installation example shown above
speaker not included

⚠ Installation requires a Network Administrator / IT Technician

Features

- Quick and easy installation
- SIP compliant, see page 2 for more information
- PoE powered (class 3, <13 Watts)
- Paging prioritization
- Plays audio from standard multicast sources
- SIP endpoint or multicast group member
- Red LED indicates call status
- Compatible with Polycom multicast paging
- Built-in high-efficiency 6 Watt class D amplifier
- Can drive up to six 8 Ohm analog speakers for more coverage
- SIP/Multicast: SIP page, SIP page and zoned multicast receive
- Support for access code to prevent unwanted SIP calls
- Hangs up on: call end signal, time-out, or touch tone command
- Network remote speaker volume control
- Mounting: Magnetically secure to speaker magnet or fasten to the 25/70V transformer mounting holes on speaker frame
- Chassis protects circuitry against plenum dust
- Diagnostics for testing speaker
- Programmable pre-page alert tone

Information: 715-386-8861
www.VikingElectronics.com

Applications

- Amplified SIP endpoint or multicast IP paging for: Schools, Hospitals, Retail Stores, Office Spaces, etc.
- Provide background music and sound masking via Multicast
- Background music for: Elevator applications, Retail Stores, Office Spaces, etc.

Specifications

Power: PoE class 3 (<13 Watts)
Dimensions: 3.63" x 2.65" x 0.90" (92.2 mm x 67.3 mm x 22.9 mm)
Shipping Weight: 0.60 lbs (0.27 kg)
Operating Temperature: -40° F to 140° F (-40° C to 60° C)
Humidity: 5% to 95% non-condensing
SIP Audio Codecs: G711u, G722 and G711a
Multicast Audio Codecs: G711u and G722
Network Compliance: IEEE 802.3 af PoE, SIP 2.0 RFC3261, 100BASE-TX with auto cross-over
Regulatory Compliance: CE, FCC Part 15 and Canada ICES-003 Class A
Maximum Output Level: 105 dB SPL @ 1M (driving one 8 Ohm speaker with sensitivity of 96dB / 1W / 1M S.P. Level)
Amplifier: 6 Watt class D
Connections: (1) RJ45 10/100 Base-T, (4) Butt Connectors

VoIP SIP System Compatibility

For compatibility and vendor specific detailed configuration instructions, see the **Viking VoIP SIP System Compatibility List**, DOD 944. To open and download this PDF file:

Scan the QR code below to open and download the **Viking VoIP SIP System Compatibility List**



- OR -

1. Go to **www.vikingelectronics.com** and enter **944** in the search box
2. Click **Application Note (DOD 944)** to open and download the PDF

Important: Exclusion from this list means only that compatibility has not been verified, **it does not mean incompatibility.** If you have questions, please call Viking Electronics at 715-386-8861.

Managing Power Losses

Maximum recommended length (in feet) for the number of 8 Ohm speakers on a wire pair to maintain a volume loss of less than 5dB. Once the length limit has been reached for the wire gauge used, if additional speakers are needed, start back at the **PSA-IP** with a 2nd parallel wire run. If the length limit is reached again, start a 3rd run, etc. See **DOD 895** for an example.

| | | | | | | |
|-----------------|-----|--------|--------|------|------|------|
| Wire Gauge Size | #16 | 2,000' | 1,000' | 665' | 500' | 400' |
| | #18 | 1,250' | 625' | 420' | 315' | 250' |
| | #20 | 800' | 400' | 265' | 200' | 160' |
| | #22 | 500' | 250' | 165' | 125' | 100' |
| | #24 | 315' | 155' | 105' | 80' | 60' |
| | | 1 | 2 | 3 | 4 | 5 |

Number of 8 Ohm Speakers on Each of the Two Wire Runs

Note 1: Mount the **PSA-IP** close to where the other speakers are installed to minimize the speaker wire run lengths.

Note 2: Using half the recommended distance or half as many speakers per run will keep the volume lost limited to 3db.

Note 3: Doubling up the wires will allow double the length, or reduce the amount of volume loss.

Note 4: Heavier gauge wire, fewer speakers per run, and shorter runs will all minimize volume loss.

Definitions

Client: A computer or device that makes use of a server. As an example, the client might request a particular file from the server.

DHCP: Dynamic Host Configuration Protocol. In this procedure the network server or router takes note of a client's MAC address and assigns an IP address to allow the client to communicate with other devices on the network.

DNS Server: A DNS (Domain Name System) server translates domain names (ie: www.vikingelectronics.com) into an IP address.

Ethernet: Ethernet is the most commonly used LAN technology. An Ethernet Local Area Network typically uses twisted pair wires to achieve transmission speeds up to 1Gbps.

Host: A computer or device connected to a network.

Host Name: A host name is a label assigned to a device connected to a computer network that is used to identify the device in various forms of network communication.

Hosts File: A file stored in a computer that lists host names and their corresponding IP addresses with the purpose of mapping addresses to hosts or vice versa.

Internet: A worldwide system of computer networks running on IP protocol which can be accessed by individual computers or networks.

IP: Internet Protocol is the set of communications conventions that govern the way computers communicate on networks and on the Internet.

IP Address: This is the address that uniquely identifies a host on a network.

LAN: Local Area Network. A LAN is a network connecting computers and other devices within an office or building.

Lease: The amount of time a DHCP server reserves an address it has assigned. If the address isn't used by the host for a period of time, the lease can expire and the address can be assigned to another host.

MAC Address: MAC stands for Media Access Control. A MAC address, also called a hardware address or physical address, is a unique address assigned to a device at the factory. It resides in the device's memory and is used by routers to send network traffic to the correct IP address. You can find the MAC address of your **PSA-IP** speaker printed on a white label on the side of the chassis (see page 4).

Router: A device that forwards data from one network to another. In order to send information to the right location, routers look at IP Address, MAC Address and Subnet Mask.

RTP: Real-Time Transport Protocol is an Internet protocol standard that specifies a way for programs to manage the real-time transmission of multimedia data over either unicast or multicast network services.

Server: A computer or device that fulfills requests from a client. This could involve the server sending a particular file requested by the client.

Session Initiation Protocol (SIP): Is a signaling communications protocol, widely used for controlling multimedia communication sessions such as voice and video calls over Internet Protocol (IP) networks. The protocol defines the messages that are sent between endpoints, which govern establishment, termination and other essential elements of a call.

Static IP Address: A static IP Address has been assigned manually and is permanent until it is manually removed. It is not subject to the Lease limitations of a Dynamic IP Address assigned by the DHCP Server. The default static IP Address is: **192.168.154.1**

Subnet: A portion of a network that shares a common address component. On TCP/IP networks, subnets are defined as all devices whose IP addresses have the same prefix. For example, all devices with IP addresses that start with 100.100.100. would be part of the same subnet. Dividing a network into subnets is useful for both security and performance reasons. IP networks are divided using a subnet mask.

TCP/IP: Transmission Control Protocol/Internet Protocol is the suite of communications protocols used to connect hosts on the Internet. TCP/IP uses several protocols, the two main ones being TCP and IP. TCP/IP is built into the UNIX operating system and is used by the Internet, making it the de facto standard for transmitting data over networks.

TISP: Telephone Internet Service Provider

WAN: Wide Area Network. A WAN is a network comprising a large geographical area like a state or country. The largest WAN is the Internet.

Wireless Access Point (AP): A device that allows wireless devices to connect to a wired network using Wi-Fi, or related standards. The AP usually connects to a router (via a wired network) as a standalone device, but it can also be an integral component of the router itself.

Wireless Repeater (Wireless Range Extender): takes an existing signal from a wireless router or access point and rebroadcasts it to create a second network. When two or more hosts have to be connected with one another over the IEEE 802.11 protocol and the distance is too long for a direct connection to be established, a wireless repeater is used to bridge the gap.

Features Overview

Front View



Side View

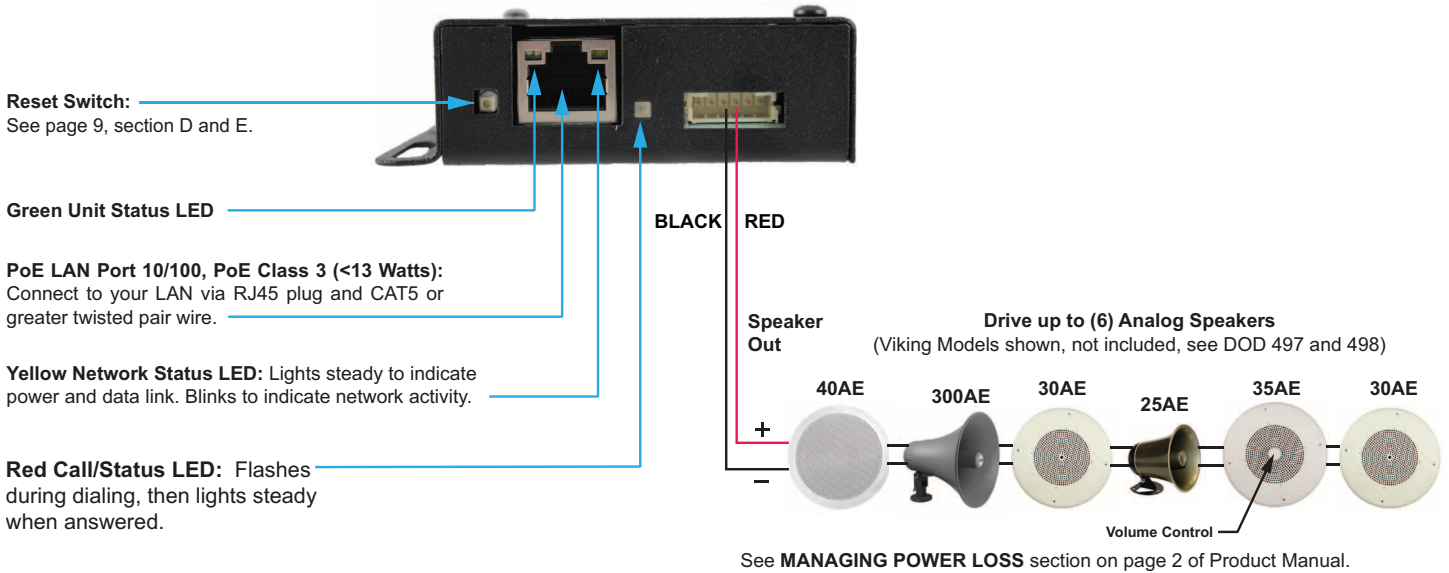

MAC Address Label: The MAC address is a unique 12 digit number used by routers to send network traffic to the correct IP address.



Mounting and Wiring the PSA-IP Paging Speaker Adapter

A. 8-Ohm Speaker Conversion



| | |
|----------------|--|
| Step 1. | Disconnect existing speaker connections and remove ceiling tile with speaker (suspended ceiling) or remove speaker from drywall. |
| Step 2. | Magnetically attach the PSA-IP to the back of the speaker magnet. Alternatively, the PSA-IP can be attached to the 70V transformer mounting holes in the speaker frame with provided screws. |
| Step 3. | Attach red and black wires from PSA-IP "Speaker" output to the speaker terminals. |
| Step 4. | Attach a Cat5 or higher cable to the PSA-IP LAN w/POE port. See Typical Installation section for details. |

B. 25V or 70V Speaker Conversion



| | |
|----------------|---|
| Step 1. | Remove ceiling tile with speaker (suspended ceiling) or remove speaker from drywall and disconnect the cable connected to the transformer input wires. |
| Step 2. | Cut the transformer output wires leaving excess wire for the speaker wire connections. Strip wire ends back 3/8 inch. |
| Step 3. | Magnetically attach the PSA-IP to the back of the speaker magnet. Alternatively, the PSA-IP can be attached to the 70V transformer mounting holes in the speaker frame with provided screws. |
| Step 4. | Cut off the terminals from the PSA-IP 's red and black speaker output wires and strip wire ends back 3/8 inch. Attach red and black wires from PSA-IP "Speaker" output to the speaker wires using provided lever connectors. Note: <i>Third lever position is used to connect additional speakers.</i> |
| Step 5. | Attach a Cat5 or higher cable to the PSA-IP LAN w/POE port. See Typical Installation section for details. |

Typical Installation on SIP Based VoIP Phone System

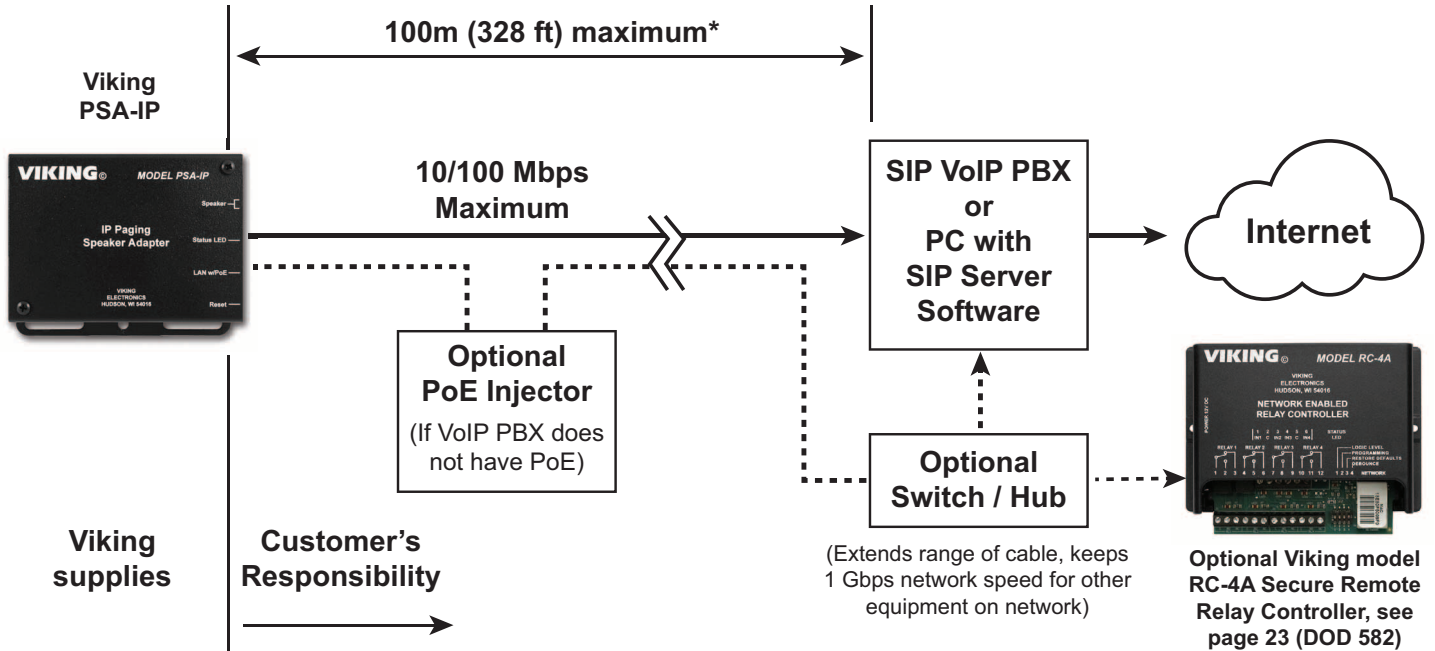

* **Note:** A PoE extender can be used for an additional 100 meters per extender. For longer runs (up to 2 km / 1.2 miles) a ethernet to fiber media converter can be used.

PC Requirements

- **IBM** compatible personal computer with: Windows 7, 8 or 10
- Adobe Acrobat Reader 8 or higher
- **PSA-IP** hardware
- Available LAN with PoE (class 3, <13 Watts)
- Ethernet cable (CAT5 minimum)
- 1 MB minimum free hard drive space for installation
- 16MB of free physical RAM

PC Programming

Download and install the programming software

1. Go to www.vikingelectronics.com and enter **PSA-IP** in the search box
2. Click **PSA-IP** in the search results
3. Scroll down the page to Downloads, click **IP Programming Software**
4. Install the programming software by saving or opening the file and then clicking on **setup Viking IP Programming.exe**
5. Follow the prompts on your screen to complete software installation
6. To start the Viking IP Programming application, click on the Viking IP Programming icon on your desk top. The main screen will appear, allowing the user to program any **PSA-IP** connected to that LAN.

Note: PC must be connected to the same LAN as the **PSA-IP**.

A. Connect / Disconnect

Open the “Viking IP Programming” software on the PC and the start screen shown below will appear. Any Viking IP speakers that are connected to the network will appear on the list. Simply select the **PSA-IP** on the list and click on the “Connect” button at the bottom or double click the selected speaker. If no username and password have been programmed and the security code of the selected unit is still set to default (845464), the PC software will not require entering a username, password or security code to connect to the **PSA-IP**. If the **PSA-IP** has been programmed with a username and password, a pop up window will ask for the username followed by the password. If the unit’s security code has been changed from “845464”, it will then prompt for the correct security code. **PSA-IP**’s have a default name of “VIKING_MK64_Vik02”, so if many **PSA-IP**’s are connected to the same network and all have the default name, MAC addresses must be used to identify each **PSA-IP**.

When finished programming, click the “Disconnect” button at the bottom. Closing the program will also automatically disconnect the unit.

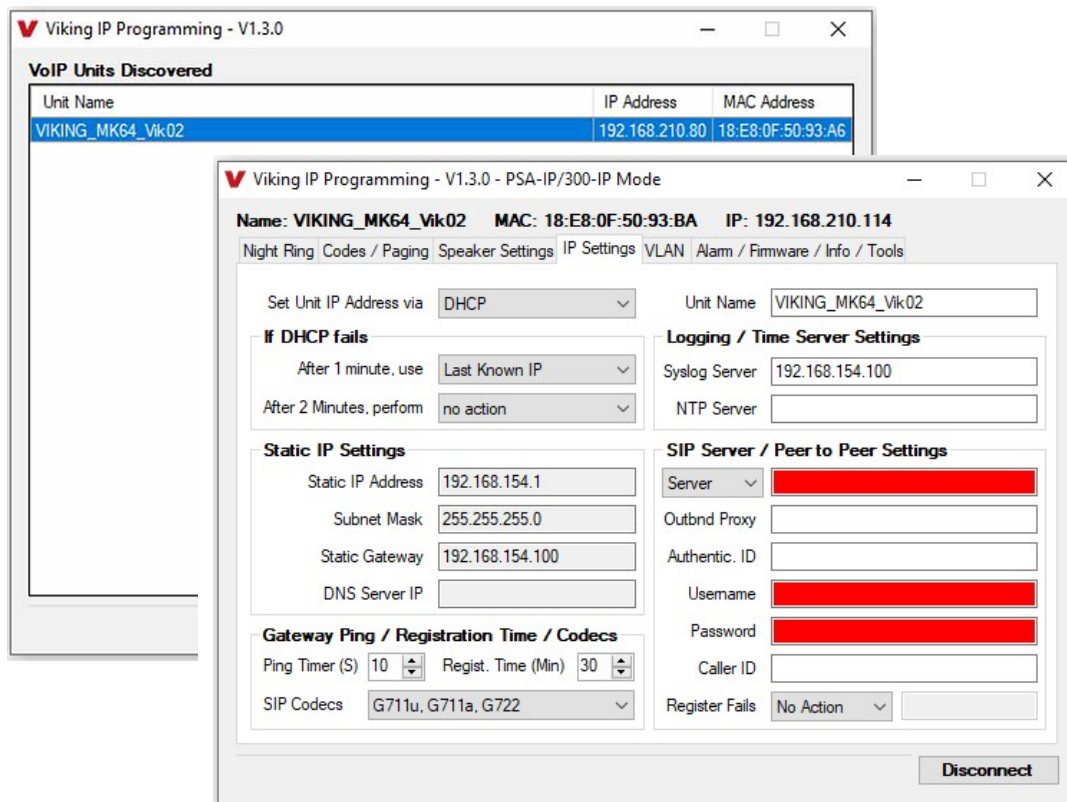

B. Configuring the PSA-IP Network Settings

| | |
|----------------|---|
| Step 1. | Open the “Viking IP Programming” software on a windows PC that is connected to the same LAN as the PSA-IP speaker to be programmed. |
| Step 2. | The window in the upper left corner of the menu will show you each PSA-IP speaker that is connected to that LAN. Select the unit with the same MAC address shown on the label located next to the Ethernet connector on the PSA-IP speaker. |
| Step 3. | Click on the “connect” button. A default PSA-IP has no username or password programmed, the security code is set to “845464” and when configured this way, you are instantly connected to the PSA-IP . If the PSA-IP has been programmed with a username and password, a pop up window will ask for the username followed by the password. If the unit’s security code has been changed from “845464”, it will then prompt for the correct security code, then click “retry”. |
| Step 4. | The program will then read and display the PSA-IP speaker’s IP and programming settings. |
| Step 5. | Click on the “IP Settings” tab. |
| Step 6. | Select the appropriate value Static IP Settings or DHCP for “Set Unit IP Address via”. Note: Changing the IP address will cause you to have to reconnect to the unit. Enter the values for the fields in “if DHCP fails” or “Static IP Settings” as needed. |
| Step 7. | Set the “Unit Name”, “Logging / Time Server Settings” as needed. |
| Step 8. | Select Peer-Peer in the “SIP Server / Peer to Peer Settings” to use the unit in Peer to Peer mode or for Multicast paging only. Select Server to register with a SIP registrar server and fill in the “Outbnd Proxy” (SIP Outbound Proxy Server Address, “ip:port”), “Authentic. ID” (SIP Authentication ID), “Username” (SIP Username, <string>), “Password” (SIP Password), and “Caller ID” (SIP Caller ID) with values from your VoIP provider. Required fields will be red when the unit is not registered. |

Viking IP Programming - V1.3.0 - PSA-IP/300-IP Mode

Name: VIKING_MK64_Vik02 MAC: 18:E8:0F:50:93:BA IP: 192.168.210.114

Night Ring Codes / Paging Speaker Settings IP Settings VLAN Alarm / Firmware / Info / Tools

Set Unit IP Address via Unit Name

If DHCP fails

After 1 minute, use

After 2 Minutes, perform

Static IP Settings

Static IP Address

Subnet Mask

Static Gateway

DNS Server IP

Logging / Time Server Settings

Syslog Server

NTP Server

SIP Server / Peer to Peer Settings

Server

Outbnd Proxy

Authentic. ID

Username

Password

Caller ID

Register Fails

Gateway Ping / Registration Time / Codecs

Ping Timer (S) Regist. Time (Min)

SIP Codecs

C. Configuring PSA-IP VLAN Settings

| | |
|----------------|---|
| Step 1. | Click on the "VLAN" tab. |
| Step 2. | Disable or enable VLAN tagging by setting the value of "VLAN Tagging". |
| Step 3. | Set the VLAN tag ID by selecting an integer (1 to PSA-94) in "ID for all packets". |
| Step 4. | Set the Priority Code Point (PCP) value for all not SIP and RTP packets in the "PCP for all packets" input (0 is default, priorities are from low to high: 0, 1, 2, 3, 4, 5, 6, 7). Set the "PCP for SIP packets" (3 is default). Set the "PCP for RTP packets" (5 is default). |

Viking IP Programming - V1.3.0 - PSA-IP/300-IP Mode

Name: VIKING_MK64_Vik02 MAC: 18:E8:0F:50:93:BA IP: 192.168.210.114

Night Ring Codes / Paging Speaker Settings IP Settings VLAN Alarm / Firmware / Info / Tools

VLAN Tagging

Please exercise caution when setting VLAN tags, as an incorrect setting can disable the ability to connect to the unit until it is manually reset to factory defaults.

VLAN Tagging

ID for all packets

PCP for all packets

PCP for SIP packets

PCP for RTP packets

D. Manually Resetting the Security Code to Enter Programming

Note: This procedure will not erase a username and password used to access the **PSA-IP** program mode. Only the security code is set to default.

| | |
|----------------|---|
| Step 1. | Power down the PSA-IP speaker by disconnecting the LAN Cable (RJ45 plug). |
| Step 2. | Press and hold the Reset button, then reconnect the LAN Cable (RJ45 plug). |
| Step 3. | Continue to hold the Reset button until you hear a single beep, silence and then 2 beeps (approximately 11 seconds). Then release the button. The LED will remain off for 5 seconds, light steady for 3 seconds, flash slowly for 3 seconds then fast flash (after the 2 beeps), indicating when to release the button. |
| Step 4. | The security code is now reset to 845464 (factory default). |
| Step 5. | You can now enter programming by following the steps in section A . |

E. Manually Resetting All Network Parameters to Factory Default

Note: This procedure will erase a username and password that are used to access the **PSA-IP** program mode.

| | |
|----------------|--|
| Step 1. | Power down the PSA-IP speaker by disconnecting the LAN Cable (RJ45 plug). |
| Step 2. | Press and hold the Reset button, then reconnect the LAN Cable (RJ45 plug). |
| Step 3. | Continue to hold the Reset button until you hear a single beep, silence and then 2 beeps (approximately 11 seconds). Continue to hold reset button until you hear 4 more beeps (approximately 6 seconds later), then release the button. The LED will remain off for 5 seconds, light steady for 3 seconds, flash slowly for 3 seconds (two beeps), fast flash for 6 seconds (4 beeps), then light steady indicating when to release the button. |
| Step 4. | You can now enter programming by following the steps in section A . |

Programming Features Index

| DESCRIPTION | Section | Page |
|---|---------|------|
| Connect / Disconnect | A | 7 |
| VLAN Settings | C | 8 |
| Unit Name | 1 | 10 |
| SIP Server | 2 | 10 |
| Peer to Peer Settings | 3 | 10 |
| Outbound Proxy | 4 | 10 |
| Authentication ID | 5 | 10 |
| Register Fails (Re-Resolve or Alternate Server) | 6 | 10 |
| Security Code (factory set to 845464) | 7 | 11 |
| Access Code (1 - 6 digits, blank = Disabled, factory set to 123456) | 8 | 11 |
| Pre Page Tone | 9 | 11 |
| Multicast Page Type | 10 | 11 |
| SIP Page / Call Priority VS Multicast | 11 | 12 |
| Multicast Paging (Standard or Polycom, factory set to Standard) | 12 | 13 |
| Multicast Paging Volume (0 - 19, factory set to 1) | 13 | 13 |
| Night Ring Timed Operation | 14 | 14 |
| Time Zone Settings / Daylight Saving Time | 15 | 14 |
| External Relay (factory set to Disabled) | 16 | 15 |
| Ext Relay Mode (Door Strike, Outbound Call, Phone or Paging, Doorbell, Ring, Ring Flash, factory set to Door Strike) | 17 | 15 |
| Ext Relay Activation Command (1 or 2 digits, factory set to **) NOTE: Relay Mode must be set to Door Strike. | 18 | 15 |
| Ext Relay Activation Time (0.5 - 99 seconds, factory set to 5 seconds) | 19 | 15 |
| Ext Relay Buzz Volume (1 - 3 or Disabled, factory set to 3) | 20 | 16 |
| Ext Relay Latch Commands (Enabled or Disabled, factory set to Enabled) NOTE: Relay Mode must be set to Door Strike | 21 | 16 |

Programming Features Index

| DESCRIPTION | Section | Page |
|---|---------|------|
| SIP Paging Volume (0 - 19, factory set to 1) | 22 | 16 |
| Ring Volume (0 - 19, factory set to 5) | 23 | 16 |
| SIP Page Length Time Out (Disabled or 1 - 9 minutes, factory set to 3 minutes) | 24 | 16 |
| Multicast Page Length Time Out (1 - 255 seconds, factory set to 180 seconds) | 25 | 16 |
| Inbound Call Mode (Disabled, Auto Answer, Auto Answer-Secure, Ring, factory set to Auto Answer) | 26 | 16 |
| Ring Cadence (factory set to Normal Ring = 2 seconds ON, 4 seconds OFF) | 27 | 17 |
| Mute Current / Next Alarm | 28 | 17 |
| Permanent Alarm Mute | 29 | 17 |
| Programming Username and Password | 30 | 17 |
| IP Firmware | 31 | 18 |
| Unit Firmware | 32 | 18 |
| Import / Export | 33 | 18 |
| Clear Speaker Settings | 34 | 18 |
| Clear IP Settings | 35 | 18 |
| Diagnostics (used to check External relay operation) | 36 | 18 |

Programming Features

1. Unit Name

Up to a 30 character unit name can be assigned to the **PSA-IP** being programmed.

2. SIP Server

Enter the IP address or URL of your SIP server or service provider in this field. The SIP server IP address is limited to 74 characters. **Note:** *If an alternate SIP server IP address is programmed, the IP address for the SIP server and alternate SIP server will be limited to 31 characters.* **Note:** *If outbound proxy is not required, enter the SIP server IP address into the Outbnd Proxy field.*

3. Peer to Peer Settings

When set to Peer to Peer mode, a SIP server is not used. The unit should be programmed with a static IP address and username, a password is not used. Caller ID can be programmed if needed. Simply call the unit by entering the programmed "username@192.168...(static IP address for the unit)". The static IP address is normally programmed into a page button on the VoIP telephones. **NOTE:** *Peer to Peer mode does not affect multicast paging.*

4. Outbound Proxy

If your SIP provider requires an outbound proxy IP address enter it in the "Outbnd Proxy" field. If outbound proxy is not required enter the SIP sever IP address into the "Outbnd Proxy" field. **NOTE:** *If not required, this field must match your SIP server IP address.*

5. Authentication ID

If your SIP provider requires Authentication ID, enter it in the "Authentic. ID" field. If Authentication ID is not required, leave this field blank.

6. Register Fails (Re-Resolve or Alternate Server)

When registered to a SIP server in the event that registration is lost you can program the unit to re-resolve using the current SIP server IP address or route pages through an alternate SIP server. With Alternate Server selected enter the IP address of the alternate SIP server in the field next to the Register Fails drop down box. **Note:** *With an alternate SIP server IP address programmed, the IP address for the SIP server and alternate SIP server will be limited to 31 characters.*

Standard Multicast Paging Tab

Viking IP Programming - V1.3.0 - PSA-IP/300-IP Mode

Name: VIKING_MK64_Vik02 MAC: 18:E8:0F:50:93:B3 IP: 192.168.210.237

Night Ring Codes / Paging Speaker Settings IP Settings VLAN Alarm / Firmware / Info / Tools

Security and Access Codes

Security Code (6 digits) 845464

Access Code (0-6 digits) 123456

Pre Page Tone Enabled

Multicast Page Type Standard

SIP Page Priority over Multicast Page

SIP page priority level Above Group 0 (Highest)

(Group 0 is highest priority, group 9 is lowest)

Paging Sources (Multicast IP and Port) - Volume Level - Timeout Enable/Disable

| Source | IP | Port | Vol | TO | Enable |
|--------|----|------|-----|----|-------------------------------------|
| 0 | | 1 | 1 | TO | <input checked="" type="checkbox"/> |
| 1 | | 1 | 1 | TO | <input checked="" type="checkbox"/> |
| 2 | | 1 | 1 | TO | <input checked="" type="checkbox"/> |
| 3 | | 1 | 1 | TO | <input checked="" type="checkbox"/> |
| 4 | | 1 | 1 | TO | <input checked="" type="checkbox"/> |
| 5 | | 1 | 1 | TO | <input checked="" type="checkbox"/> |
| 6 | | 1 | 1 | TO | <input checked="" type="checkbox"/> |
| 7 | | 1 | 1 | TO | <input checked="" type="checkbox"/> |
| 8 | | 1 | 1 | TO | <input checked="" type="checkbox"/> |
| 9 | | 1 | 1 | TO | <input type="checkbox"/> |

Disconnect

7. Security Code

The security code allows the user/installer to program the **PSA-IP** with a PC and the required "Viking IP Programming" software. If the security code is left as default, the PC software won't require entering a security code when connecting to the **PSA-IP**. It is recommended that the factory set security code be changed. The security code can be set back to default by holding the Reset button while the **PSA-IP** powers up. See section D on page 9 for details. It can also be defaulted by connecting to the unit with the IP Programming Software and clicking on the "Clear Speaker Settings" button on the "Alarm / Firmware" tab. **Factory Setting:** 845464

NOTE: The security code must be 6 digits and cannot include a * or #.

8. Access Code

The Access Code is primarily used along with the "Auto Answer Secure" Inbound Call Mode to force inbound SIP page callers to dial the Access Code before they can make a SIP page. The Access Code also comes into play when using the relay of the **PSA-IP** to open a door or gate. When you call the **PSA-IP** and the unit automatically answers the call (see Programming section 38), you must dial the Access Code before you are allowed to operate the door strike relays, as extra security on inbound calls. Once a tenant has entered the correct Access Code, 2 beeps are heard and the user can now enter any "Operation Commands" (see Operation section D). The Access Code can be disabled if this basic security is not required. **Factory Setting:** 123456

Note: The Access Code can be 1 - 6 digits in length and cannot include a * or # or match the numbers used for the Security Code.

9. Pre Page Tone

When enabled, a short beep will be heard prior to SIP or Multicast paging audio. The volume of the Pre Page Alert Tone will match the volume setting of the SIP or Multicast page. **Factory Setting:** Enabled

10. Multicast Page Type

Select Standard or Polycom as the source of multicast paging. If Polycom is selected as the source, the screen will change to show its options (see next page). For Details see #11 on Page 13.

Factory Setting: Standard (shown above)

Polycom Multicast Paging Tab

11. SIP Page Priority over Multicast Page

Incoming **PSA-IP** SIP call audio streams can be programmed to have priority over any of the 10 standard Multicast paging groups. Simply use the “Sip Page Priority Level” drop down menu to select which Multicast group you want SIP calls to have priority over. **Factory Setting:** “0” (SIP is highest priority).

When Polycom is selected as the Multicast Page Type, the “SIP Page Priority Level” can be set to “Polycom” or “None”. See the following tables for the order of priorities with each setting. As shown, Polycom Group 25 multicast is the highest priority. The priority options allow you to determine the priorities for Polycom Groups 1 through 24 multicast signals and SIP paging. **Factory Setting:** Polycom

| Paging Priorities (SIP Page Priority Level set to “Polycom”) | Paging Priorities (SIP Page Priority Level set to “None”) |
|--|---|
| Polycom Group 25 | Polycom Group 25 |
| SIP Paging | Polycom Groups 1-24 |
| Polycom Groups 1-24 | SIP Paging |

12. Standard or Polycom Multicast Paging

Standard

When using standard Multicast Paging, up to 10 multicast paging groups can be programmed into each **PSA-IP** speaker. Each multicast group is defined by a multicast address and port number. Each multicast group is assigned a priority, allowing simultaneously arriving pages to be serviced based on importance. A timeout check box can be selected for each paging group. See Multicast Page Timeout under Paging Settings to adjust the timeout from 1 - 255 seconds. Only one timeout time can be programmed for all groups. The volume for each multicast group can be programmed separately.

Assigning Priority to standard Multicast Paging

The **PSA-IP** will prioritize simultaneous audio streams according to their priority in the Paging Sources list. Group 0 will have the highest priority while group 9 will have the lowest priority. Group 9 is useful for a low priority stream such as background music. Group 0 is useful for high priority streams such as emergency messages.

The multicast paging groups can also be used for up to ten different paging zones for receiving audio streams. A paging zone can consist of one or many **PSA-IP** multicast speakers. There is no limit to how many speakers can be in a given paging zone. Each multicast group is defined by a multicast address and port number. Each multicast group is assigned a priority, allowing simultaneously arriving pages to be serviced based on importance.

Polycom

Polycom IP phones send multicast audio to a specific IP address and port. A total of 25 groups can be used, with group 25 generally reserved for an emergency broadcast. Set the Multicast Page Type to "Polycom". The Viking IP programming page will then show "Polycom Paging Source and Group Subscriptions". Polycom phones will default to IP address 224.0.1.116 and port 5001 for multicast. Under "Polycom Paging Source and Group Subscriptions", enter the IP address and port you chose in the Polycom IP phone as "Multicast IP address" and "port" (Paging/PTT Configuration page). Select the paging groups the **PSA-IP** should subscribe to. Any multicast audio sent to the correct IP address, port number and a subscribed group will be heard from the Speaker terminals. Group 1 is the lowest priority and group 25 is the highest. The Volume and Timeout can be selected globally, although the timeout does not affect group 25. **Factory Setting:** all Groups selected

13. Multicast Paging Volume

The volume of each individual standard multicast page can be adjusted from 0 - 19. When polycom paging is used, the paging volume is set globally for all 25 groups. **Factory Setting:** 1

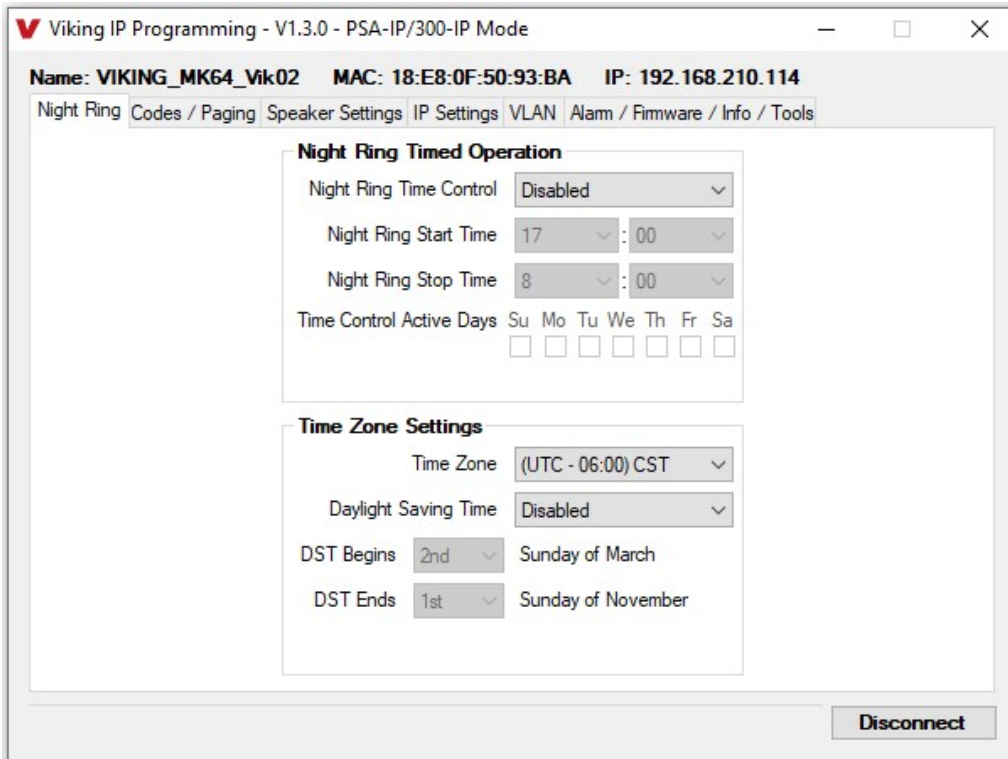

14. Night Ring Timed Operation

When Night Ring Timed Operation is enabled, if a SIP call is received during the programmed Start and Stop times, the **PSA-IP** will output loud ring on the “Speaker Out” terminals. This is selectable for each day of the week. When outside of the Night Ring timing window, the Inbound Call Mode setting will determine how SIP calls are handled. **NOTE:** For timed Night Ringing the unit must be synced with a time server. If the Night Ringing feature is enabled in the software you will be asked to use Viking Time Server when changes are applied. The address will be entered by the software automatically.

15. Time Zone Settings / Daylight Savings Time

When using the Night Ring Timed Operation the **PSA-IP** must be synced with the network time. Set the Time Zone Settings to match the settings on the network the unit is connected to for proper timed operation.

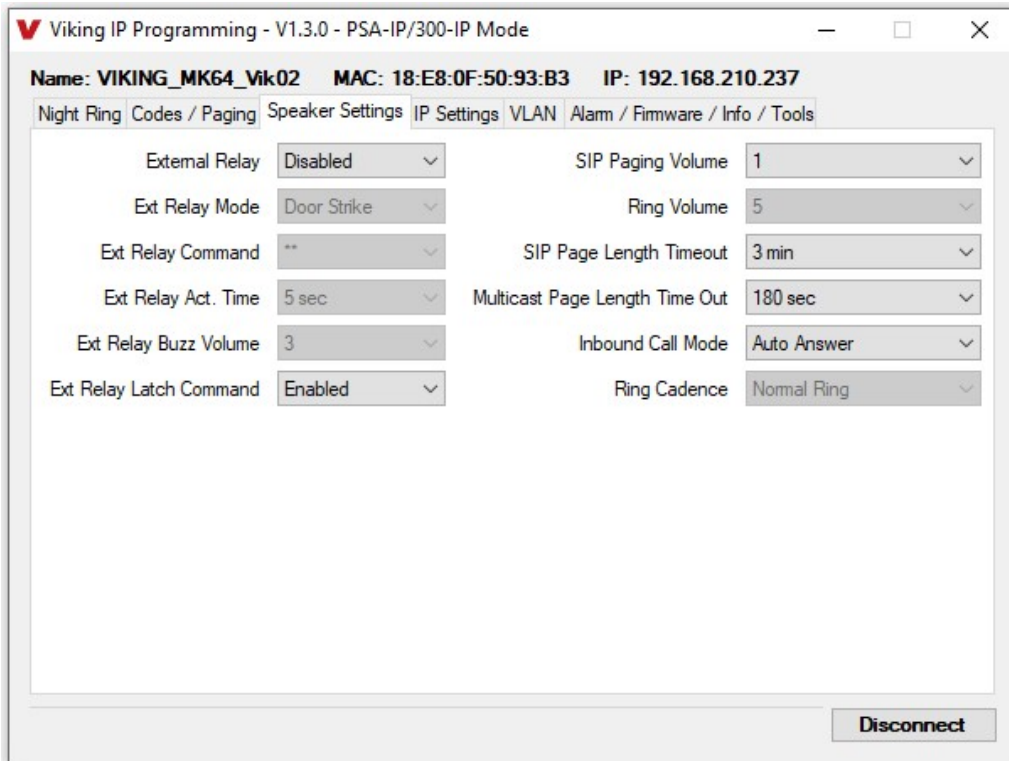

16. External Relay

A Viking remote model **RC-4A** relay controller can be used to activate up to four external relays (see page 23). With the external relay set to “Enable EXT 1,2,3,4,+” the **PSA-IP** will activate an optional RC-4A relay fcontroller.

Factory Setting: Disabled

17. Ext Relay Mode

Door Strike Mode: When programmed for Door Strike Mode the relay is intended for door strike, magnetic lock or gate control.

Paging Mode: When programmed for Phone/Paging Mode the relay will activate continuously for the duration of any SIP or multicast page or any inbound or outbound call to or from the speaker phone. This mode is useful for triggering paging amplifiers, etc.

Ring Mode: When programmed for Ring Mode the relay will continuously activate while the ringing extension is called. This mode is useful for activating a Viking model **SL-2** strobe light, etc.

Ring Flash Mode: When programmed for Ring Flash Mode the relay will momentarily turn on and off in a 400 ms on/off cadence while the ringing extension is called. This mode is useful for activating a Viking **LPL-1** Remote Visual Indicator, etc.

18. Ext Relay Command

The one or two digit code stored in the Ext Relay Command is the touch tone command that the person being called must enter on their phone in order to momentarily activate the relay to control a door strike, magnetic lock, gate controller, or other device. The code can contain the characters 0-9, # or *. The code cannot match a relay latching command (*1, *0). The code must be entered while the remote phone is communicating with the speaker phone.

Factory Setting: **.

19. Ext Relay Activation Time

The value stored in the Relay Activation Time is the amount of time the relay will be energized after a correct momentary touch tone command is entered. This number can range from 0.5 - 99 seconds. This also affects timing in Doorbell Mode. **Factory Setting:** 5 seconds

20. Ext Relay Buzz Volume

The relay activation tone is a buzzing sound that is heard from the speaker when the door strike relay is activated. After the called party enters the correct relay activation command, the called party will hear 2 short confirmation beeps and the speaker will output a buzzing sound (relay activation tone) while the door strike relay is activated. The tone (buzz) length will match the relay activation time up to a maximum of 5 seconds. The tone (buzz) can be programmed to three different volume settings 1 = Low, 2 = Medium, 3 = High or it can be disabled. When disabled, the confirmation beeps will not be heard. **Factory Setting:** 3

21. Ext Relay Latch Command

When set to "Enabled" the Operation Commands (*0 to *1) to Un-Latch or Latch the relay are enabled. These can be entered on a inbound call after the access code is dialed (if programmed).

When set to "Disabled" the Operation Commands (*0 to *1) to Un-Latch or Latch the relay are disabled. Disabling the latch commands can be useful in applications where you want to eliminate the possibility of inadvertently entering a latch command leaving a gate open/closed, etc.

Factory Setting: Enabled

22. SIP Paging Volume

The SIP Paging volume can be set from 0 - 19. 0 = lowest volume setting, 19= highest volume setting. Adjusting this will set the Speaker volume level for SIP Paging. This setting does not affect multicast volume settings.

Factory Setting: 1

23. Ring Volume

When set to Ring Mode, The **PSA-IP** will output a loud ring when it is called. The level can be adjusted from 0 - 19.

Factory Setting: 5

24. SIP Page Length Timeout

This feature selects the maximum length of time that SIP Paging calls can be connected. Programmable in increments of 1 minute up to a maximum of 9 minutes or disabled. With the SIP Paging length disabled, the **PSA-IP** speaker must rely on a call ended signal or touch tone # to hang-up. **Factory Setting:** 3 minutes

25. Multicast Page Timeout

The Multicast Page Length Timeout can be programmed from 1 - 255 seconds in one second increments. The Time Out can be disabled, allowing any length of page or continuous background music. Only one timeout time can be programmed for all multicast paging groups. When using standard Multicast Paging, a timeout checkbox can be selected for each paging group. When using Polycom Multicast Paging, the timeout checkbox enables the timeout globally on groups 1 through 24. There is no timeout for a page to the emergency group 25.

Factory Setting: 180 seconds

26. Inbound Call Mode

The Inbound Call Mode determines how the **PSA-IP** handles incoming SIP calls. One option is to generate a loud ring sound through the speaker. The **PSA-IP** can also auto answer a SIP call to transmit a page or control the relay. The "secure" options for auto answer require the callers to dial the access code in order to transmit a page or activate the optional **RC-4A** relays. **Factory Setting:** Auto Answer

Disabled: Inbound SIP calls are not allowed. For more security use the Auto Answer Secure Mode.

Auto Answer: Inbound calls are auto answered on the first ring. For more security use the Auto Answer Secure Mode.

Auto Answer Secure: Inbound SIP calls are auto answered and the caller must dial the access code in order to make a SIP page.

Ring: In the "Ring" mode the speaker phone will not automatically answer an incoming call but will output a loud ring signal out of the speaker in a factory programmed 2 seconds ON, 4 seconds OFF ring pattern. There are four available ring cadences.

27. Ring Cadence

The Ring Cadence can be programmed to one of four different cadences. **Factory Setting:** Normal Ring

Normal Ring (single ring: 2 seconds ON, 4 seconds OFF)

Double Ring (double ring: 1 second ON, 0.5 second OFF, 1 second ON, 3.5 seconds OFF)

Short-Short-Long (triple ring: 0.5 second ON, 0.5 second OFF, 0.5 second ON, 0.5 second OFF, 1 second ON, 3 seconds OFF)

Short-Long-Short (triple ring: 0.5 second ON, 0.5 second OFF, 1 second ON, 0.5 second OFF, 0.5 second ON, 3 seconds OFF)

The screenshot shows the 'Viking IP Programming - V1.3.0 - PSA-IP/300-IP Mode' window. At the top, it displays the unit name 'VIKING_MK64_Vik02', MAC address '18:E8:0F:50:93:BA', and IP address '192.168.210.114'. Below this are several tabs: 'Night Ring', 'Codes / Paging', 'Speaker Settings', 'IP Settings', 'VLAN', and 'Alarm / Firmware / Info / Tools'. The 'IP Settings' tab is active, showing 'Dynamic IP Settings' with fields for Unit IP Address (192.168.210.114), Subnet Mask (255.255.255.0), Gateway IP Address (192.168.210.18), and DNS Server IP Address (192.168.210.252). To the right, 'Firmware Versions' shows IP (R8.11.1912) and Unit (V1.5) with 'Update IP' and 'Update Unit' buttons. Below that, 'Import / Export' has 'Import Data' and 'Export Data' buttons. The 'SIP / Network Failure Alarm' section shows 'SIP Registration Status' as 'Not Registered', 'Current Alarm Status' as 'Activated - SIP' (highlighted in red), and an 'Alarm Muted' checkbox. There are also buttons for 'Mute Current / Next Alarm' and a dropdown for 'Permanent Alarm Mute' set to 'Alarm Tones Disabled'. At the bottom left, 'Programming Username and Password' has a 'Set Username and Password' button. A 'Disconnect' button is at the bottom right.

28. Mute Current / Next Alarm

With Alarm Tones Enabled a network failure alarm will be indicated by providing 3 beeps every 30 seconds. A network failure indicates the unit is not registered to the SIP server or there is a communication failure with the gateway. The three beeps can be muted by clicking on “Mute Current / Next Alarm”. The Status LED will continue to flash to assist troubleshooting. The alarm beeps can also be permanently disabled, see 44. Permanent Alarm Mute.

Factory Setting: Disabled

29. Permanent Alarm Mute

Alarm Tones are disabled by default. To enable alarm tones select “Alarm Tones Enabled”.

30. Programming Username and Password to Restrict Access to Programming

To increase security, a username and password can be programmed to limit access to the **PSA-IP** using Viking IP Programming software. When no username and password are programmed and the security code is still set to default (845464), the PC software will not require a username, password or security code when connecting to the **PSA-IP**. If the **PSA-IP** has been programmed with a username and password, a pop up window will ask for the username followed by the password. If the unit’s security code has been changed from default (845464), it will then prompt for the correct security code.

If the username and password are unknown, they can only be erased by resetting all network parameters to default with the reset button (see section E on page 9). If the username and password are known but you wish to erase them, that can be accomplished by exporting the data from the **PSA-IP** (“Alarm / Firmware” tab of Viking IP Programming), resetting all network parameters to default with the reset button (see section E on page 9) and then importing the data back into the speaker.

31. IP Firmware

Update IP is currently not available. The ability to update IP firmware will be made available in a later release of Viking IP Programming software. If an IP firmware update is needed, Viking Technical Support will assist in updating the IP firmware.

32. Unit Firmware

If new **PSA-IP** firmware is available, after opening the programming software a pop up window will ask if you would like to update firmware. Another way to update is accomplished by clicking the speaker firmware “Update Unit” button. You can then browse to the folder that contains the HEX file for updating the unit’s firmware. This method is typically only used when Viking Technical Support has sent you updated firmware.

33. Import / Export

The Import / Export feature is useful for backing up all the **PSA-IP’s** programming or for importing programming when installing multiple units with a majority of the same programming.

34. Clear Speaker Settings

Clicking on the “Clear Speaker Settings” button in programming will reset all of the Programming Features back to their factory default settings. **NOTE:** *This command will not change or reset your IP settings.*

35. Clear IP Settings

Clicking on the “Clear IP Settings” will reset all of the IP settings back to their factory default settings. This also clears paging Group settings and Addresses. **NOTE:** *This will not affect any speaker or paging settings.*

36. Diagnostics

The Diagnostics section in the Viking IP Programming can be used to test the functionality of the optional **RC-4A** relays.

A. Inbound SIP Calls

How inbound SIP calls are handled depends on the Inbound Call Mode selected (see Programming section 35), the current programming for Night Ring Timed Operation if enabled (see Programming section 17), the current time of day and day of week. If Night Ring Timed Operation is disabled and the Inbound Call Mode is set to Auto Answer, the **PSA-IP** will automatically answer inbound calls, provides a Pre Page Alert Tone if enabled and allows paging through the unit. When the Inbound Call Mode is set to Auto Answer – Secure, the **PSA-IP** auto answers inbound calls but the party must dial the Access Code before they are allowed to page from the unit. The Inbound Call Mode also has options that allow the unit to output a loud ring on any inbound SIP calls. The Ring option outputs a fixed volume ring and is adjustable (see Programming section 28). If Night Ring Timed Operation is enabled and an inbound SIP call is received between the programmed start and stop times and the current day is a programmed active day, the unit will automatically output a loud ring instead of following the Inbound Call Mode programming. This allows for loud ring at certain times of the day/days of the week and paging all other times/days of the week.

B. Multicast

The **PSA-IP** can be set to one of two modes for multicasting, Standard or Polycom. Polycom is only used when Polycom IP phones are used. To change to Polycom multicast, go to the “Paging” tab and change the “Multicast Page Type” to Polycom.

Standard Multicast Paging (Factory Setting)

Up to 10 multicast paging groups can be programmed into each unit and each group is assigned a priority level allowing simultaneous arriving multicast pages to be handled based on importance. Low priority groups are often used for low priority streams like background music and high priority groups are used for high priority streams such as emergency messages. Group 0 is the highest priority, and Group 9 is the lowest. A timeout limit can be set and either enabled or disabled for each multicast group. The volume of each group can be programmed and SIP Paging can be assigned either higher or lower priority than all or some of the multicast groups (see Programming section 10).

Polycom Multicast Paging

Polycom phones send multicast audio to a specific IP address and port. A total of 25 groups can be used and groups 1 through 24 can individually be enabled/disabled in each **PSA-IP**. Group 25 is always enabled, as group 25 is generally used for emergency broadcasts. Any multicast page made from a Polycom phone (on the same LAN) to the programmed IP address, port and to an enabled group will play through the **PSA-IP** speaker. The priority of Polycom sources ranges from group 1 (lowest) to group 25 (highest). SIP Paging can be assigned either higher or lower priority than Polycom group 1 through 24 multicast paging (see the table in programming section 11 for Polycom paging priorities). Multicast page timeout can be enabled/disabled globally for groups 1 through 24 (there is no timeout for group 25) and the length of the Multicast page timeout is adjustable. The volume for Polycom multicast is set globally for all groups.

C. Operation Commands (Relay Mode must be set to “Door Strike”)

The following commands can be entered after the **PSA-IP** answers an inbound SIP call, when the Inbound Call Mode is set to auto answer. After the unit auto answers the call, one beep will be heard if Pre Page Alert Tone is enabled. If the Access Code has been disabled, you can now enter the Operation Commands listed below. If an Access Code has been programmed, enter the Access Code digits. Once the correct code has been entered, two beeps will be heard and you can now enter the Operation Commands listed below.

| Feature | Tone Tone Command | Description |
|--------------------|-------------------|--|
| Activate Ext Relay | ** or __ __ | Momentarily activate ext relay (1 or 2 digits, factory set to **). |
| Un-Latch Ext Relay | *0 | Un-latch* (deactivate) the ext relay. |
| Latch Ext Relay | *1 | Latch* (continuously activate) the ext relay. |
| Disconnect | # | Disconnects or forces the speaker to hang up. |

* **NOTE:** Latching commands must be enabled in programming.

Troubleshooting

If the unit cannot register with the programmed SIP server, the “Status” LED will blink on and off every two seconds until communication is restored. This alerts a potential user of a problem with the device that will prevent SIP calls from being accepted.

Optional Secure Remote Relay Control Using a Viking Model RC-4A

For applications requiring remote relay control for up to 4 relays, a Viking model **RC-4A** Remote Relay Controller can be used. The relay controller is mounted securely inside the building and connected to the same LAN as the **PSA-IP**. The **PSA-IP** will send an encrypted message to the **RC-4A** to activate its relays which control the door strikes / gates.

Up to four **PSA-IP**'s can communicate with one **RC-4A** allowing you to securely control four entrances.

When using an **RC-4A** for remote relay control the **PSA-IP** should be set to "Ext 1,2,3,4" (see Programming section 19).

For more information on the **RC-4A**, see DOD 582.

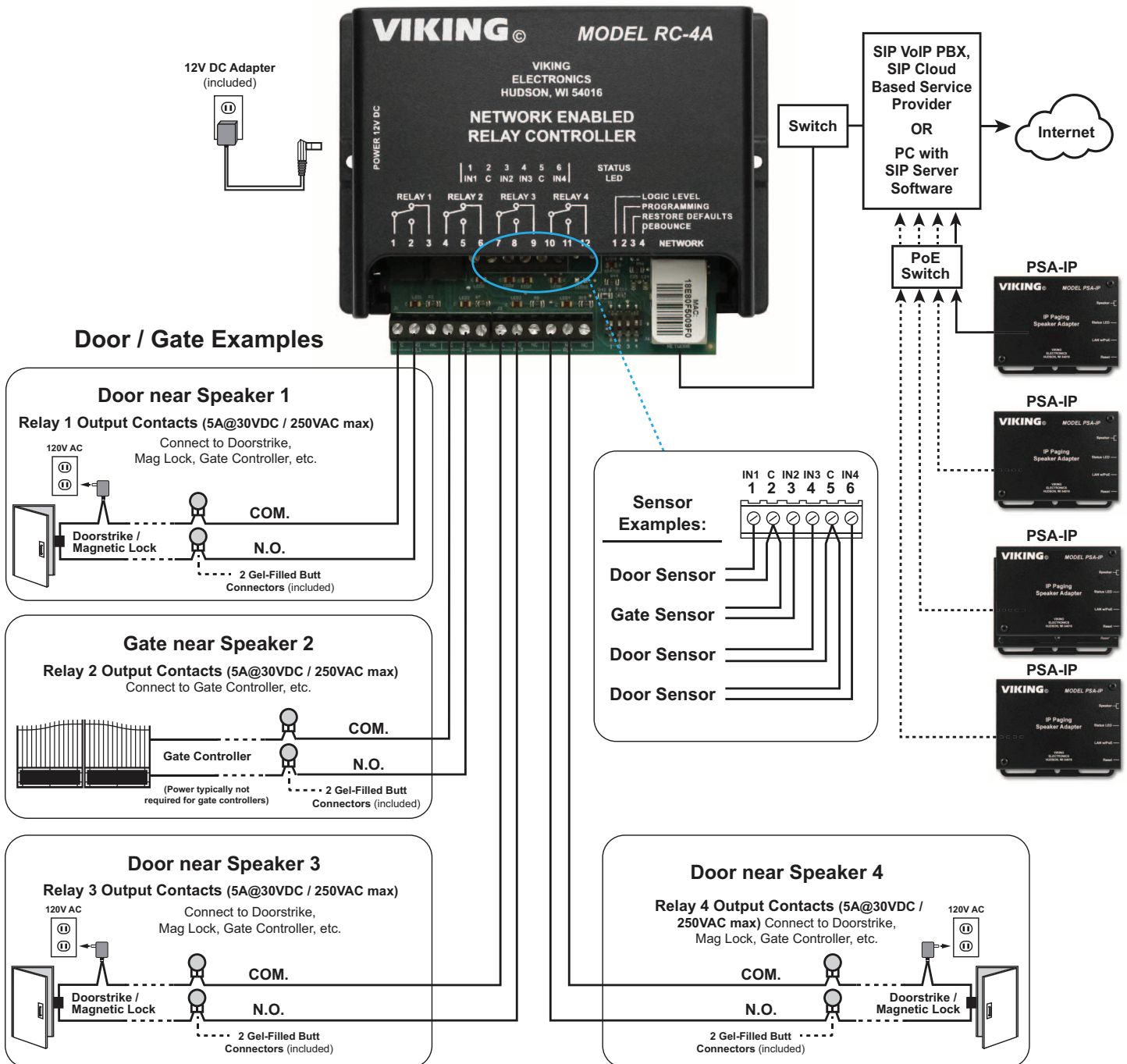

Related Products

Analog Speakers and Paging Horns

The **25AE**, **30AE**, **35AE**, and **40AE** paging speakers provide additional economical paging coverage to existing Viking paging units (**40-IP**, **PA-2A**, **PA-15**, **PA-30**, **PA-60**, **HF-3W**, **M2W**) or to any system with an 8 Ohm output.

In outdoor, factory or warehouse environments, **25AE** paging horns are the best method of producing understandable sound. In these environments the directional design allows the installer to focus the sound cone down aisles and toward work areas.

In office and restaurant environments, it is best to distribute sound more evenly. Ceiling mounted **30AE**, **35AE**, or **40AE** speakers in close proximity offer the best distribution and are cost effective. The **35AE** speakers include a volume control.



30AE

35AE

40AE

25AE

300AE

30AE and 35AE Ceiling Speakers

- White metal grill
- Flush mount in office ceilings
- Mounting hardware included
- Excellent frequency response
- The **35AE** includes a volume control

40AE Ceiling Speakers

- Attractive with a modern look
- Flush mounts into a 9.5" to 10" diameter hole
- Integral mounting system
- Excellent sound quality

25AE Paging Horn

- Adjustable base for easy mounting and directional adjustment
- Compact design for discreet mounting

300AE Paging Horn

- 30 Watt 8 Ohm / 70V Paging Horn

Tile Bridge for Ceiling Speakers

The **SA-TBA** is a tile bridge designed to mount 8 inch loud speaker and bridges both 2 ft x 2 ft and 2 ft x 4 ft ceiling tiles. It is compatible with the Viking models **SA-1S**, **30AE**, **35AE**, and **40AE** speakers. The **SA-TBA** tile bridge is constructed of 24 gauge cold rolled steel with an electro galvanized rust-resistant finish.



IP Speaker for SIP Endpoint Paging

The Viking model **40-IP** Ceiling/Wall Speaker enables SIP endpoint paging and also allows for standard paging and background music via multicast. The speaker easily connects with a single CAT5/6 cable from your PoE switch. Its shallow depth allows the speaker to be conveniently mounted in a standard 2" x 4" stud wall or ceiling.

Line-level audio output connections are provided for connecting to an external amplifier. Speaker output connections are also provided to directly drive additional analog speakers. The LED on the **40-IP** can be programmed to light during paging. For more info, see **DOD 503**.



SIP / Multicast Paging Adapter

The Viking model **PA-IP** SIP / Multicast Paging Adapter provides an interface between new VoIP phone systems (hardware or hosted/cloud based) and analog paging systems, eliminating the need for an ATA or FXS port. The **PA-IP** can be used for standard SIP endpoint paging or multicast paging and background music.

The unit easily connects with a single CAT5/6 cable from your PoE switch. The night bell feature is programmable for time of day and day of week to enable loud ringing for after hour incoming calls. Alternatively the night bell feature can be enabled by a contact closure across the trigger input terminals. Line-level audio output connections are provided for connecting to an external amplifier.

A built-in 6 Watt class D amplifier with speaker output connections are also provided to drive up to 6 analog speakers. A programmable relay output is provided for triggering external amplifiers, etc. For more info, see **DOD 505**.



PA-IP

Warranty

IF YOU HAVE A PROBLEM WITH A VIKING PRODUCT, CONTACT VIKING TECHNICAL SUPPORT: 715-386-8666

Our Technical Support Department is available for assistance Monday through Friday 8:00am to 5:00pm central time. So that we can give you better service, before you call please:

1. Know the model number, the serial number and what software version you have (see serial label).
2. Have the Product Manual in front of you.
3. It is best if you are on site.

RETURNING PRODUCT FOR REPAIR

The following procedure is for equipment that needs repair:

1. Customer must contact Viking's Technical Support Department at 715-386-8666 to obtain a Return Authorization (RA) number. The customer MUST have a complete description of the problem, with all pertinent information regarding the defect, such as options set, conditions, symptoms, methods to duplicate problem, frequency of failure, etc.
2. Packing: Return equipment in original box or in proper packing so that damage will not occur while in transit. The original product boxes are not designed for shipping - an overpack box is required to prevent damage in transit. Static sensitive equipment such as a circuit board should be in an anti-static bag, sandwiched between foam and individually boxed. All equipment should be wrapped to avoid packing material lodging in or sticking to the equipment. Include ALL parts of the equipment. C.O.D. or freight collect shipments cannot be accepted. Ship cartons prepaid to:

**VIKING ELECTRONICS
1531 INDUSTRIAL STREET
HUDSON, WI 54016**

3. Return shipping address: Be sure to include your return shipping address inside the box. We cannot ship to a PO Box.
4. RA number on carton: In large printing, write the RA number on the outside of each carton being returned.

RETURNING PRODUCT FOR EXCHANGE

The following procedure is for equipment that has failed out-of-box (within 10 days of purchase):

1. Customer must contact Viking's Technical Support at 715-386-8666 to determine possible causes for the problem. The customer MUST be able to step through recommended tests for diagnosis.
2. If the Technical Support Product Specialist determines that the equipment is defective based on the customer's input and troubleshooting, a Return Authorization (RA) number will be issued. This number is valid for fourteen (14) calendar days from the date of issue.
3. After obtaining the RA number, return the approved equipment to your distributor. Please reference the RA number on the paperwork being shipped back with the unit(s), and also the outside of the shipping box. The original product boxes are not designed for shipping - an overpack box is required to prevent damage in transit. Once your distributor receives the package, they will replace the product over the counter at no charge. The distributor will then return the product to Viking using the same RA number.
4. **The distributor will NOT exchange this product without first obtaining the RA number from you. If you haven't followed the steps listed in 1, 2 and 3, be aware that you will have to pay a restocking charge.**

TWO YEAR LIMITED WARRANTY

Viking warrants its products to be free from defects in the workmanship or materials, under normal use and service, for a period of two years from the date of purchase from any authorized Viking distributor. If at any time during the warranty period, the product is deemed defective or malfunctions, return the product to Viking Electronics, Inc., 1531 Industrial Street, Hudson, WI., 54016. Customer must contact Viking's Technical Support Department at 715-386-8666 to obtain a Return Authorization (R.A.) number.

This warranty does not cover any damage to the product due to lightning, over voltage, under voltage, accident, misuse, abuse, negligence or any damage caused by use of the product by the purchaser or others. This warranty does not cover non-EWP products that have been exposed to wet or corrosive environments. This warranty does not cover stainless steel surfaces that have not been properly maintained.

NO OTHER WARRANTIES. VIKING MAKES NO WARRANTIES RELATING TO ITS PRODUCTS OTHER THAN AS DESCRIBED ABOVE AND DISCLAIMS ANY EXPRESS OR IMPLIED WARRANTIES OR MERCHANTABILITY OR FITNESS FOR ANY PARTICULAR PURPOSE.

EXCLUSION OF CONSEQUENTIAL DAMAGES. VIKING SHALL NOT, UNDER ANY CIRCUMSTANCES, BE LIABLE TO PURCHASER, OR ANY OTHER PARTY, FOR CONSEQUENTIAL, INCIDENTAL, SPECIAL OR EXEMPLARY DAMAGES ARISING OUT OF OR RELATED TO THE SALE OR USE OF THE PRODUCT SOLD HEREUNDER.

EXCLUSIVE REMEDY AND LIMITATION OF LIABILITY. WHETHER IN AN ACTION BASED ON CONTRACT, TORT (INCLUDING NEGLIGENCE OR STRICT LIABILITY) OR ANY OTHER LEGAL THEORY, ANY LIABILITY OF VIKING SHALL BE LIMITED TO REPAIR OR REPLACEMENT OF THE PRODUCT, OR AT VIKING'S OPTION, REFUND OF THE PURCHASE PRICE AS THE EXCLUSIVE REMEDY AND ANY LIABILITY OF VIKING SHALL BE SO LIMITED.

IT IS EXPRESSLY UNDERSTOOD AND AGREED THAT EACH AND EVERY PROVISION OF THIS AGREEMENT WHICH PROVIDES FOR DISCLAIMER OF WARRANTIES, EXCLUSION OF CONSEQUENTIAL DAMAGES, AND EXCLUSIVE REMEDY AND LIMITATION OF LIABILITY, ARE SEVERABLE FROM ANY OTHER PROVISION AND EACH PROVISION IS A SEPARABLE AND INDEPENDENT ELEMENT OF RISK ALLOCATION AND IS INTENDED TO BE ENFORCED AS SUCH.

If trouble is experienced with the **PSA-IP** Speaker, for repair or warranty information, please contact:

Viking Electronics, Inc., 1531 Industrial Street, Hudson, WI 54016 715-386-8666

WHEN PROGRAMMING EMERGENCY NUMBERS AND (OR) MAKING TEST CALLS TO EMERGENCY NUMBERS:

Remain on the line and briefly explain to the dispatcher the reason for the call. Perform such tests in off-peak hours, such as early morning or late evenings.

Product Support: 715-386-8666

Due to the dynamic nature of the product design, the information contained in this document is subject to change without notice. Viking Electronics, and its affiliates and/or subsidiaries assume no responsibility for errors and omissions contained in this information. Revisions of this document or new editions of it may be issued to incorporate such changes.