

8201 SIP PoE Intercom FW Version 1.5

Installation & Configuration



Order Codes

8201 SIP PoE Intercom

Table of Contents

IMPORTANT SAFETY INFORMATION	7
ABOUT THE ALGO SIP 8201 SIP POE INTERCOM	8
GETTING STARTED - QUICK INSTALL & TEST	9
INSTALLATION	10
WEB INTERFACE.....	11
WIRING CONNECTIONS.....	12
NETWORK CONNECTION	12
DOOR CONTROL	13
SERIAL CONTROL.....	13
DOOR SENSOR (DRY CONTACT INPUT).....	13
BLUE CALL BUTTON.....	14
RESET.....	14
WEB INTERFACE LOGIN – STATUS AND LOGIN	15
STATUS.....	15
BASIC SETTINGS TAB – SIP.....	16
SIP DOMAIN (PROXY SERVER).....	16
SIP EXTENSION	16
AUTHENTICATION ID	16
AUTHENTICATION PASSWORD.....	17
EXTENSION TO DIAL.....	17
BASIC SETTINGS TAB – FEATURES	18
SPEAKER VOLUME.....	18
AUTOMATIC GAIN CONTROL (AGC).....	18
ANSWER INBOUND CALL.....	19
ANSWER TONE	19
OUTBOUND RING LIMIT	19
RINGBACK TONE	19
ALLOW CALL BUTTON TO END ACTIVE CALL	19
G.722 SUPPORT.....	19
MAXIMUM CALL DURATION.....	19
DOOR SENSOR CONNECTOR	19
BASIC SETTINGS TAB – DOOR CONTROL.....	20
NETWORK DOOR CONTROLLER ADDRESS.....	20
NETWORK DOOR CONTROLLER PASSWORD.....	21
MOMENTARY OPEN CODE	21
DURATION	21
LATCH OPEN CODE.....	21
LATCH CLOSED CODE	21
DOOR UNLOCK TONE.....	21
LOCAL DOOR RELAY	21

- BASIC SETTINGS TAB – MULTICAST 22**
 - MULTICAST MODE (SLAVE SELECTED)..... 22
 - MULTICAST TYPE - REGULAR 22
 - NUMBER OF ZONES 23
 - SLAVE ZONES 23
 - MULTICAST TYPE – POLYCOM GROUP PAGING/PUSH-TO-TALK..... 23
- ADVANCED FEATURES TAB 25**
- ADVANCED SETTINGS TAB - NETWORK 26**
 - PROTOCOL 26
 - VLAN MODE..... 26
 - VLAN ID 27
 - VLAN PRIORITY 27
 - DIFFERENTIATED SERVICES (6-BIT DSCP VALUE) 27
- ADVANCED SETTINGS TAB – ADMIN 28**
 - PASSWORD..... 28
 - CONFIRMATION 28
 - DEVICE NAME (HOSTNAME)..... 29
 - INTRODUCTION SECTION ON STATUS PAGE 29
 - WEB INTERFACE SESSION TIMEOUT..... 29
 - LOG LEVEL..... 29
 - LOG METHOD 29
 - LOG SERVER 29
 - WEB INTERFACE PROTOCOL 29
 - FORCE STRONG PASSWORD..... 29
 - ALLOW SECURE SIP PASSWORD 30
 - SNMP SUPPORT (V1 GET ONLY) 30
- ADVANCED SETTINGS TAB – TIME..... 31**
 - TIMEZONE 31
 - NTP TIME SERVERS 1/2/3/4..... 31
 - NTP TIME SERVER SOURCE 31
 - DEVICE DATE/TIME..... 31
- ADVANCED SETTINGS TAB – PROVISIONING 33**
 - MD5 CHECKSUM..... 34
 - GENERATING A GENERIC CONFIGURATION FILE 34
 - GENERATING A SPECIFIC CONFIGURATION FILE..... 35
- ADVANCED SETTINGS TAB – TONES 36**
 - UPLOADING CUSTOM RING TONES (WAV FILES) 36
- ADVANCED SETTINGS TAB – ADVANCED SIP 37**
 - OUTBOUND PROXY 37
 - STUN SERVER 37
 - REGISTER PERIOD (SECONDS)..... 37
 - KEEP-ALIVE METHOD..... 37
 - SERVER REDUNDANCY FEATURE 38

BACKUP SERVER #1	38
BACKUP SERVER #2	38
POLLING INTERVALS (SECONDS).....	38
POLL ACTIVE SERVER	38
AUTOMATIC FAILBACK	38
POLLING METHOD	38
ADVANCED SETTINGS TAB – ADVANCED MULTICAST.....	39
AUDIO SYNC	39
ZONE DEFINITION	40
PAGE TONE AND PAGE VOLUME.....	40
POLYCOM SLAVE TONES	41
SYSTEM TAB - MAINTENANCE.....	42
DOWNLOAD CONFIGURATION FILE.....	42
RESTORE CONFIGURATION FILE	42
RESTORE CONFIGURATION TO DEFAULTS	42
REBOOT THE DEVICE	42
METHOD.....	42
FIRMWARE IMAGE	43
MD5 CHECKSUM.....	43
SYSTEM – SYSTEM LOG	43
SPECIFICATIONS	44
8061 IP RELAY CONTROLLER	45
CONFIGURING THE 8061	46
FCC COMPLIANCE STATEMENT	48

Important Safety Information

This product is powered by a certified limited power source (LPS), Power over Ethernet (PoE); through CAT5 or CAT6 connection wiring to an IEEE 802.3af compliant network PoE switch. The product is intended for installation indoors or on outdoor perimeter of a building. If used in an outdoor environment, additional protective measures must be taken according to the installation manual. All wiring connections to the product must be in the same building. If the product is installed beyond the building perimeter or used in an inter-building application, the wiring connections must be protected against overvoltage / transient. Algo recommends that this product be installed by a qualified electrician.

If you are unable to understand the English language safety information then please contact Algo by email for assistance before attempting an installation support@algosolutions.com.

Consignes de Sécurité Importantes

Ce produit est alimenté par une source d'alimentation limitée certifiée (alimentation par Ethernet); des câbles de catégorie 5 et 6 joignent un commutateur réseau à alimentation par Ethernet homologué IEEE 802.3af. Le produit est conçu pour être installé à l'intérieur ou dans une zone adjacente à un édifice; selon le manuel d'installation, des mesures de sécurité additionnelles s'avèrent alors nécessaires. Tout le câblage rattaché au produit doit se trouver dans le même édifice. Si le produit est installé au-delà du périmètre de l'édifice ou utilisé pour plusieurs édifices, le câblage doit être protégé des surtensions transitoires. Algo recommande qu'un électricien qualifié se charge de l'installation de ce produit.

Si vous ne pouvez comprendre les consignes de sécurité en anglais, veuillez communiquer avec Algo par courriel avant d'entreprendre l'installation au support@algosolutions.com.

Información de Seguridad Importante

Este producto funciona con una fuente de alimentación limitada (Limited Power Source, LPS) certificada, Alimentación a través de Ethernet (Power over Ethernet, PoE); mediante un cable de conexión CAT5 o CAT6 a un conmutador de red con PoE en cumplimiento con IEEE 802.3af. El producto se debe instalar en lugares cerrados o en el perímetro de un edificio al aire libre. Si se utiliza en un ambiente al aire libre, se deben tomar medidas de protección adicionales de acuerdo con el manual de instalación. Todas las conexiones cableadas al producto deben estar en el mismo edificio. Si el

producto se instala fuera del perímetro del edificio o se utiliza en una aplicación en varios edificios, las conexiones cableadas se deben proteger contra sobretensión o corriente transitoria. Algo recomienda que la instalación de este producto la realice un electricista calificado.

Si usted no puede comprender la información de seguridad en inglés, comuníquese con Algo por correo electrónico para obtener asistencia antes de intentar instalarlo: support@algosolutions.com.

Wichtige Sicherheitsinformationen

Dieses Produkt wird durch eine zertifizierte Stromquelle mit begrenzter Leistung (LPS – Limited Power Source) betrieben. Die Stromversorgung erfolgt über Ethernet (PoE – Power over Ethernet). Dies geschieht durch eine Cat-5-Verbindung oder eine Cat-6-Verbindung zu einer IEEE 802.3af-konformen Ethernet-Netzwerkweiche. Das Produkt wurde konzipiert für die Installation innerhalb eines Gebäudes oder außerhalb eines Gebäudes. Bei der Anwendung außerhalb eines Gebäudes müssen zusätzliche Schutzmaßnahmen gemäß der Gebrauchsanweisung durchgeführt werden. Alle Kabelverbindungen zum Produkt müssen im selben Gebäude bestehen. Wenn das Produkt jenseits des Gebäudes oder für mehrere Gebäude genutzt wird, müssen die Kabelverbindungen vor Überspannung und Spannungssprüngen geschützt werden. Algo empfiehlt das Produkt von einem qualifizierten Elektriker installieren zu lassen.

Sollten Sie die englischen Sicherheitsinformationen nicht verstehen, kontaktieren Sie bitte Algo per Email bevor Sie mit der Installation beginnen, um Unterstützung zu erhalten. Algo kann unter der folgenden E-Mail-Adresse erreicht werden: support@algosolutions.com.

安全须知

本产品由认证的受限电源（LPS），以太网供电（PoE），通过CAT5或CAT6线路联接至IEEE 802.3af兼容的PoE网络交换机供电。本产品适用于室内或建筑物周边安装。如用于室外环境，必须按照安装手册采用附加的保护措施。所有联接本产品的线路必须源自同一建筑物。本产品如需用于超出建筑物周边范围或跨建筑物的安装，线路联接部分必须有过压和瞬态保护。Algo建议本产品由专业电工安装。

如果您对理解英文版安全须知有问题，安装前请通过电子邮件和Algo联系，support@algosolutions.com。

Important Safety Information



EMERGENCY COMMUNICATION

If used in an emergency communication application, the 8201 SIP PoE Intercom should be routinely tested. SNMP supervision is recommended for assurance of proper operation. Contact Algo for other methods of operational assurance including the use of the integrated microphone for automated "sound to air" acoustic testing.

WET OR OUTDOOR ENVIRONMENTS

The 8201 SIP PoE Intercom is intended for indoor or outdoor locations and may be subjected to spray or weather provided the rear wiring cavity is properly sealed to prevent water ingress.

Gaskets included with the 8201 SIP PoE Intercom may be effective against water ingress on some, but not all surfaces in which case additional protective measures must be taken such as a perimeter sealant.

CAT5 or CAT6 connection wiring to an IEEE 802.3af compliant network PoE switch must not leave the building perimeter without adequate lightning protection.

When the Intercom is connected to wiring that exits the building, there is potential risk of lightning induced electrical surges or high voltages from fault conditions. To reduce risk, outdoor wiring should be protected by Earth grounded conduit whenever possible. Relay input and output connections must not leave the building perimeter without adequate lightning protection.

About the Algo SIP 8201 SIP PoE Intercom

Ideal for secure business entrances, emergency intercoms, and residential gates, Algo's 8201 SIP PoE Intercom provides hands-free intercom capability, entrance security with door unlock control, rugged weatherproof design, and superior audio performance.

Fully compatible with SIP industry standards, the 8201 SIP PoE Intercom will work with most hosted or enterprise SIP-base servers supporting third-party SIP endpoints.

The 8201 SIP PoE Intercom is configured using central provisioning features or by accessing a web interface using browsers such as Google Chrome, Firefox, or Internet Explorer.

What is Included

- 8201 SIP PoE Intercom
- Gaskets

What is not Included

- Optional 8061 IP Relay Controller
- This Installation Guide (www.algosolutions.com/8201/guide)

Getting Started - Quick Install & Test



This guide provides important safety information which should be read thoroughly before permanently installing the intercom.

1. Connect the 8201 SIP PoE Intercom to an IEEE 802.3af compliant PoE network switch. The blue call button on the front will turn on. After about 30 seconds, a beep will signal the completion of the boot process.
2. After the boot is complete, press the blue call button on the 8201 to hear the IP address. (Once the SIP Server field is populated in the 8201 web interface, the call button will contact the preconfigured extension when pressed.) The IP address may also be discovered by downloading the Algo locator tool to find Algo devices on your network:
www.algosolutions.com/locator

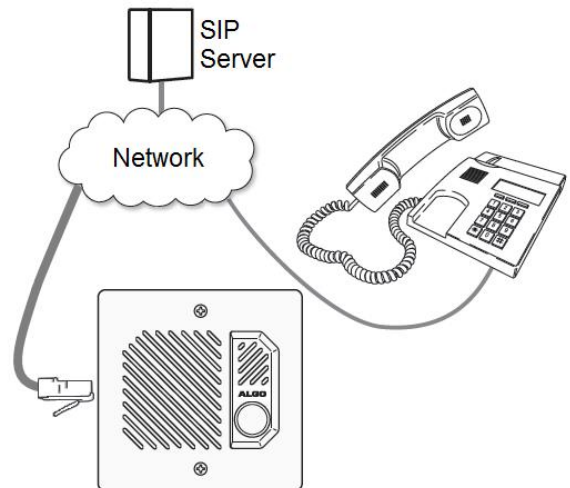

3. Access the 8201 SIP PoE Intercom web page by entering the IP address into a browser (Chrome, IE, Firefox etc) and login using the default password **algo**.
4. Enter the IP address for the SIP server into the SIP Domain field under the **BASIC SETTINGS > SIP** tab.
5. Enter the SIP Extension, Authentication ID, and Password. Also enter the target Dialing Extension that the Intercom will call.
6. Press the call button on the 8201 Intercom, then answer the phone and communicate over the Intercom. Press the digit 6 on the phone keypad to activate the door control relay for three seconds (if applicable).

Installation

The 8201 SIP PoE Intercom is weather protected for outdoor installation. However if network cabling extends beyond the perimeter of the building then adequate lightning protection is required to protect the cabling and network switch from lightning surges. No lightning protection is required by UL or CSA if the 8201 SIP PoE Intercom is located on the outside wall of a building and the wiring is inside the perimeter of the building.

1. Remove the 8201 SIP PoE Intercom faceplate
2. Determine if you want a flush or surface mount installation

For surface mount:

- Discard the flush mount gasket.
- Verify the correct orientation of the surface mount gasket.
- Thread the wires through the center hole, then through the surface mount bracket.
- Fasten the surface mount bracket at the desired location on the wall

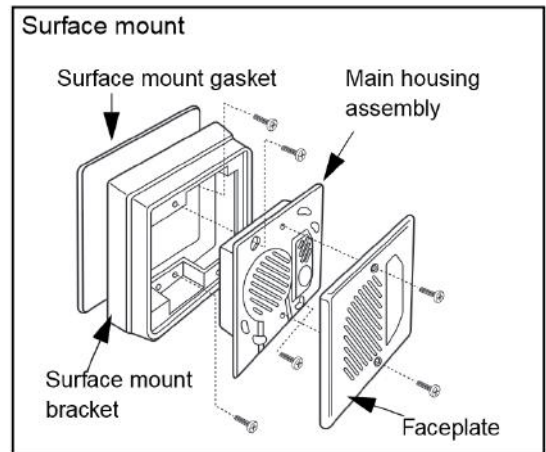

For flush mount:
(into an electrical box embedded in the wall)

- Discard the surface mount gasket and bracket.
- Slide the flush mount gasket onto the main housing assembly.

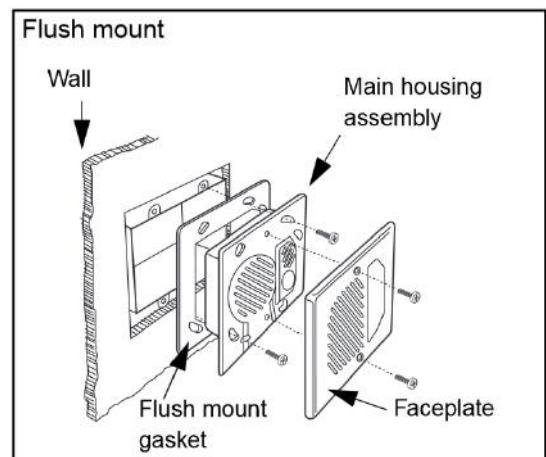

Web Interface

The 8201 SIP PoE Intercom is configurable using the web interface or provisioning features.

After boot up, the speaker will beep and the intercom will have obtained an IP address. If there is no DHCP server the 8201 SIP PoE Intercom will default to the static IP address **192.168.1.111**.

Before the 8201 is configured, the call button on the front can be pressed to play the IP address over the speaker. (Once the SIP Server field is populated on the 8201 web interface, the call button will contact the preconfigured extension when pressed.) The IP address may also be discovered by downloading the Algo locator tool to find Algo devices on your network: www.algosolutions.com/locator

Enter the IP address (e.g. 192.168.1.111) into a browser such as Google Chrome, Firefox, or Internet Explorer (other than IE9). The web interface should be visible and the default password will be **algo** in lower case letters.

Wiring Connections



Note: The screw inputs by default are closed to prevent vibration when the speaker is active. To use, open the desired input using a screw driver, insert the wire, and close the input again. Ensure that other inputs remain closed if they are not in use.

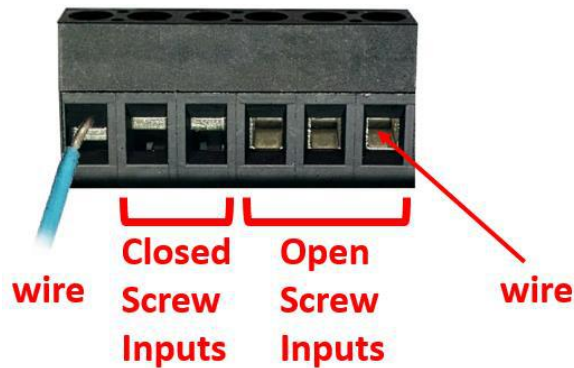

Network Connection

Connect RJ45 jack from PoE network switch or non-PoE network and 48V 350 mA IEEE 802.3af compliant power injector.

There are two lights on the Ethernet jack:

Green light: On when Ethernet is working, flickers off to indicate activity on the port.

Amber light: Off when successful 100Mbps link is established. Typically on only briefly at power up.

Under normal conditions, the Amber light will turn on immediately after the Ethernet cable is first connected. This indicates that PoE power has been successfully applied. Once the device connects to the network, it will switch to the Green light instead, which will typically flicker indicating traffic on the network.

Door Control

Provides both normally open and normally closed relay contacts.

Serial Control

****Coming Soon****

Door Sensor (Dry Contact Input)

It can be configured as an auxiliary Call Button input. Additional features coming soon.

Blue Call Button

The call button light will be steady during power up and when the intercom is idle.

When making a call, the call button light will flash rapidly, while the call is ringing at the far-end phone. Once the call is answered, the flashing will slow down.

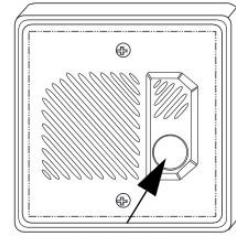

Call button

Reset

The 8201 SIP PoE Intercom can only be reset during a power up. To reset: reboot or power cycle the 8201 SIP PoE Intercom, wait until the blue call buttons flashes and then press and hold the button until it begins a double flash pattern. Release the call button and allow the unit to complete its boot process. **Do not press the blue call button until it begins flashing.**

A reset will set all configuration options to factory default including the password.

Web Interface Login – Status and Login

The web interface requires a password which is "**algo**" by default. This password can be changed using the *Admin* tab after logging in the first time.

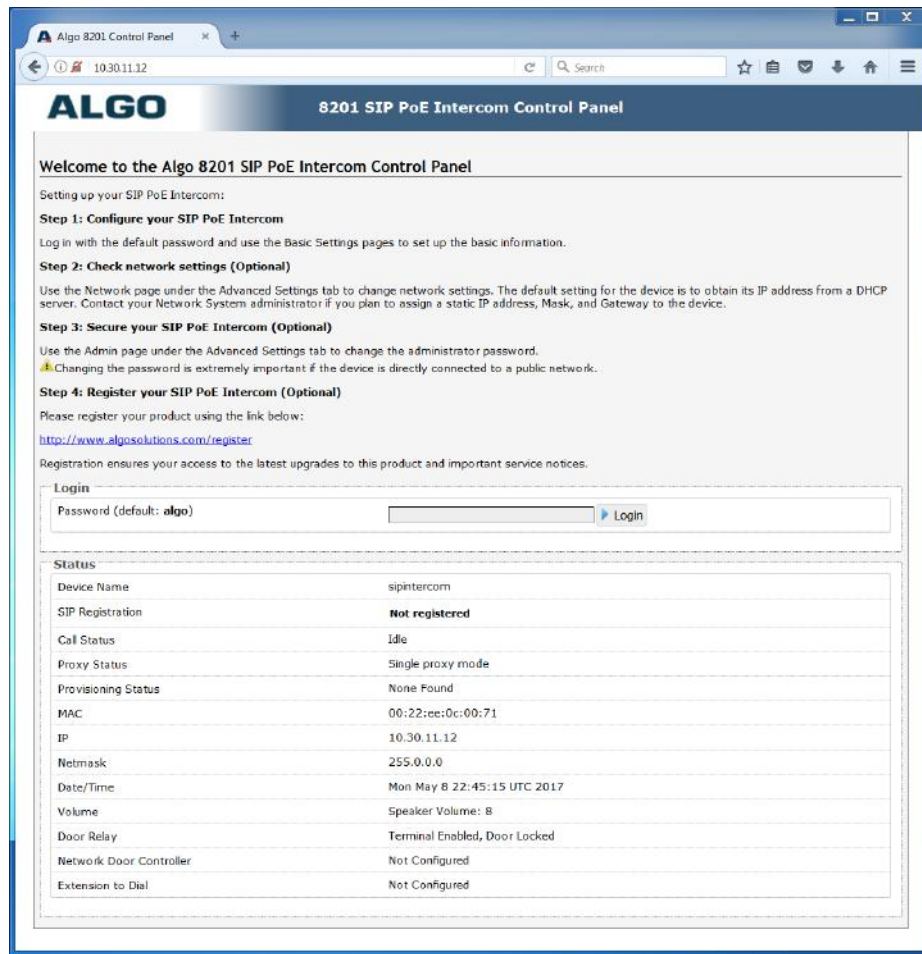

Status

The device's Status page will be available before and after log on. The section can be used to check 8201's SIP Registration status of the SIP extensions, Call Status, Proxy Status, Extension to Dial, Door Controller status, and general MAC, IP, Netmask, and Date/Time information.

Basic Settings Tab – SIP

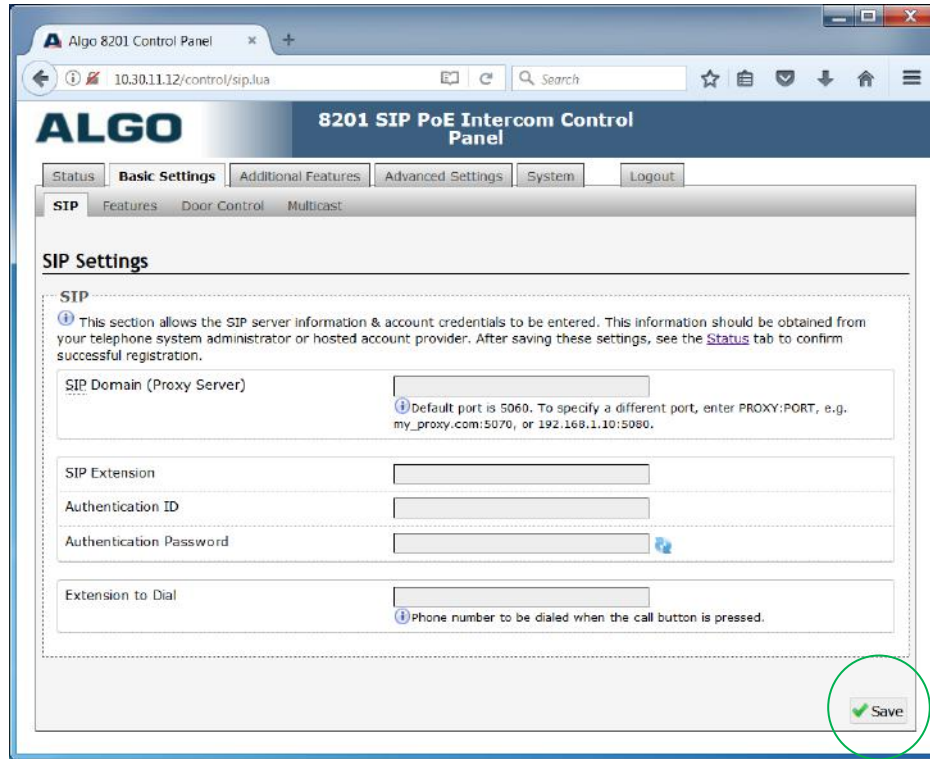

Note: Any time changes are made to settings in the Web Interface the "Save" key must be clicked to save the changes

SIP Domain (Proxy Server)

SIP Server Name or IP Address.

SIP Extension

Used to register the 8201 on the SIP Server.

Authentication ID

May also be called Username for some SIP servers and in some cases may be the same as the SIP extension.

Authentication Password

SIP account password provided by the system administrator.

Extension to Dial

Enter the phone number that will be dialed when the call button is pressed. This can also be a Hunt Group number. Ensure that voice mail is not reached.

Basic Settings Tab – Features

The screenshot shows the 'Basic Settings' tab with the 'Features' sub-tab selected. The settings are organized into five sections:

- Audio:** Speaker Volume is set to 8. Automatic Gain Control (AGC) is enabled.
- Inbound Call:** Answer Inbound Call is enabled. Answer Tone is set to '<Default>'.
- Outbound Call:** Outbound Ring Limit is set to 'No limit'. Ringback Tone is set to '<Default>'. Allow Call Button to End Active Call is disabled.
- General:** G.722 Support is enabled. Maximum Call Duration is set to 'None'.
- Input:** Door Sensor Connector is disabled.

A 'Save' button with a green checkmark is located at the bottom right of the configuration area.

Speaker Volume

Intercom speaker audio level of the 8201 from 1 (lowest) to 10 (highest).

Automatic Gain Control (AGC)

Normalizes the audio level. This ensures audio level heard at the speaker is always at a consistent level, independent of the phone that is used to answer the call.

Answer Inbound Call

Allow the 8201 to auto answer an inbound call. By default, this functionality is activated.

Answer Tone

Select a tone to be played over the speaker when the intercom answers an inbound call. Use only Default, or custom uploaded file. The other pre-installed tone files all contain silence at the end in order to generate ring "cadence" of 6 seconds. This silence will block the voice path for several seconds at the start of a call.

Outbound Ring Limit

This feature can be used to set a limit on how long the intercom will ring before timing out. If the call is not answered within this time period, the 8201 will go back to an idle state.

Ringback Tone

Select an audible ringback tone to be played on the 8201 speaker until the call is answered.

Allow Call Button to End Active Call

If enabled, allows the visitor to end an active call by pressing the call button.

G.722 Support

Enable or disable the G.722 codec.

Maximum Call Duration

Select the maximum call length. The call will be terminated once the maximum time is reached. In the event that a call inadvertently reaches voicemail or gets accidentally left on hold, this setting ensures that the 8201 returns on-hook.

Door Sensor Connector

This input can be configured as an auxiliary call button input. Additional features coming soon.

Basic Settings Tab – Door Control

The 8201 can be used with the optional 8061 SIP Relay Module for additional door security as it is located inside the building. This section allows you to configure the 8061 IP Relay Controller settings (if used), as well as the settings for the on-board relay. For more information about the 8061, see “8061 IP Relay Controller” on page 45.

The screenshot shows the 'Basic Settings' tab for 'Door Control'. It includes a navigation bar with 'Status', 'Basic Settings', 'Additional Features', 'Advanced Settings', 'System', and 'Logout'. Below the navigation bar, there are sub-tabs for 'SIP', 'Features', 'Door Control', and 'Multicast'. The main content area is titled 'Door Controller Settings' and contains several sections:

- Informational text:**
 - This section allows security codes to be configured for unlocking the door. This can be done from inside the building using the DTMF keypad on the inside telephone that answers the call.
 - An electronic doorstrike is required for unlocking the door. These doorstrikes typically require their own power system and a contact closure for activation. The Algo doorphone can provide a contact closure in one of three ways:
 - Door Relay directly on the doorphone (included; for low security applications only)
 - Algo door unlock device connected to "Serial Control" terminals (sold separately or as a bundle)
 - Network Door Controller located elsewhere on the network (sold separately)
- Network Door Controller:**
 - Network Door Controller Address: [Text input field]
 - Network Door Controller Password: [Text input field with masked characters]
- Door Unlock via Telephone DTMF:**
 - Momentary Open Code: [Text input field with '6']
 - 1-4 digit code that can be used to unlock the door for a brief period of time (as set by the Duration field). Leave this field blank to disable this feature.
 - Duration: [Dropdown menu with '3 seconds']
 - The duration for which to unlock the door when the Momentary Open Code is entered.
 - Latch Open Code: [Text input field]
 - 1-4 digit code that can be used to unlock the door indefinitely. Leave this field blank to disable this feature.
 - Latch Closed Code: [Text input field]
 - 1-4 digit code that will lock the door again when it is latched open. Leave this field blank to disable this feature.
- Tone:**
 - Door Unlock Tone: [Radio buttons for 'Enabled' and 'Disabled', with 'Disabled' selected]
- Local Door Controller:**
 - Local Door Relay: [Dropdown menu with 'Door Control']

A 'Save' button is located at the bottom right of the form.

Network Door Controller Address

IP address of the optional 8061 IP Relay Controller. For 8061 configuration, see page 45.

Network Door Controller Password

Used to authenticate the link between the 8201 and the 8061. Ensure that the two devices have matching passwords. Default password is ***algo***.

Note: the Relay Module Password is used solely to secure the link between the 8201 and the 8061. It is not the same as the Momentary Open Code.

Momentary Open Code

1-4 digit DTMF code that can be used to unlock the door for a brief period of time. Leave this field blank to disable this feature.
(Default: 6)

Duration

The time period for which to unlock the door when the Momentary Open Code is entered. From ¼ to 30 seconds.

Latch Open Code

1-4 digit DTMF code that can be used to unlock the door indefinitely. Leave this field blank to disable this feature.

Latch Closed Code

1-4 digit DTMF code that will lock the door again when it is latched open. Leave this field blank to disable this feature.

Door Unlock Tone

A sound can be played when a door is unlocked, to create awareness.

Local Door Relay

Enable or disable the Door Control Relay on the 8201.

Basic Settings Tab – Multicast

The 8201 SIP PoE Intercom is able to act as a multicast Slave, allowing it to multicast messages from a Master device (e.g. 8180, 8186, 8188, or 8301) over the intercom speaker. Please note, the 8201 is not meant for paging in large areas. Instead we recommend using the 8186 SIP Horn Speaker for outdoor or wide-area applications (e.g. factory, warehouse), and the 8180 SIP Audio Alerter or 8188 SIP Ceiling Speaker for any other indoor paging requirements.

The screenshot displays the 'Multicast Settings' configuration page. At the top, there are navigation tabs: Status, Basic Settings (selected), Additional Features, Advanced Settings, System, and Logout. Below these are sub-tabs: SIP, Features, Door Control, and Multicast (selected). The main content area is titled 'Multicast Settings' and is divided into two sections. The first section, 'Multicast Mode', contains four settings: 'Multicast Mode' (radio buttons for None and Slave/Receiver, with Slave/Receiver selected), 'Multicast Type' (radio buttons for Regular (RTP), Polycom Group Page, and Polycom Push-to-Talk, with Regular (RTP) selected), 'Number of Zones' (radio buttons for Basic Zones Only and Basic and Expanded Zones, with Basic and Expanded Zones selected), and 'RTP Extension Header' (radio buttons for Enabled and Disabled, with Disabled selected). The second section, 'Slave/Receiver Zone Settings', contains 'Basic Slave Zones' with checkboxes for Priority Call (checked), All Call, and Music, and checkboxes for Zone 1 (checked), Zone 2, Zone 3, Zone 4, Zone 5, and Zone 6. Below this is 'Expanded Slave Zones' with checkboxes for zones *10 through *50. At the bottom of this section are 'Select All' and 'Clear All' buttons. A green 'Save' button is located at the bottom right of the form.

Multicast Mode (Slave Selected)

If slave mode is enabled the 8201 intercom speaker will activate when receiving a multicast message.

Multicast Type - Regular

Select "Regular" if solely multicasting to Algo SIP endpoint(s) and/or multicast-enabled phone(s) that use RTP audio packets.

Number of Zones

Select “basic” zones if configuring nine or fewer multicast zones or “expanded” to configure up to 50 zones. The expanded zones have the same behaviour as the basic slave zones, but are hidden by default to simplify the interface.

Slave Zones

Select one or more multicast zones for the 8201 SIP PoE Intercom to monitor. Note that multicast zone priority is based on the zone definition list order (top to bottom).

The screenshot shows the 'Multicast Settings' page with the following configuration:

- Multicast Mode:** None, Slave/Receiver
- Multicast Type:** Regular (RTP), Polycom Group Page, Polycom Push-to-Talk
- Polycom Slave Settings:**
 - Polycom Zone:** 224.0.1.116:5001
 - Polycom Slave Channels:**
 - Group 1, Group 2, Group 3, Group 4, Group 5
 - Group 6, Group 7, Group 8, Group 9, Group 10
 - Group 11, Group 12, Group 13, Group 14, Group 15
 - Group 16, Group 17, Group 18, Group 19, Group 20
 - Group 21, Group 22, Group 23, Group 24, Group 25

Multicast Type – Polycom Group Paging/Push-to-Talk

The 8201 SIP PoE Intercom may receive multicast paging compatible with Polycom “**on premise group paging**” protocol.

To configure the 8201 as a slave to play Polycom page announcements, select “Group Page” or “Push-to-Talk”. Then enter the Polycom Zone (IP Address and Port) that matches the configuration of the Polycom phones and Channels. The “Default Channel” is the target group in a Polycom paging environment.

The Polycom phone used as page audio source for the 8201(s), must be configured to use either the G.711 or G.722 audio codec. **The Polycom phone(s) must also be configured with the**

“Compatibility” setting (“`ptt.compatibilityMode`”) disabled in order for this codec setting to be applied.

If using a Polycom phone as the Multicast master, a tone may be set for any of the 25 Polycom Groups configured on the Algo device. If an Algo device is used as a Multicast master, a tone does not have to be set as the Algo master will provide its own tone. Polycom Group Tones can be set in Advanced Settings > Advanced Multicast tab.

Advanced Features Tab

****Custom Application Section Only****

Advanced Settings Tab - Network

Protocol

DHCP is an IP standard designed to make administration of IP addresses simpler. When selected, DHCP will automatically configure IP addresses for each 8201 SIP PoE Intercom on the network. Alternatively the 8201 SIP PoE Intercom can be set to a static IP address.

VLAN Mode

Enables or Disables VLAN Tagging. VLAN Tagging is the networking standard that supports Virtual LANs (VLANs) on an Ethernet network. The standard defines a system of VLAN tagging for Ethernet frames and the accompanying procedures to be used by bridges and switches in handling such frames. The standard also provides provisions for a quality of service prioritization scheme commonly

known as IEEE 802.1p and defines the Generic Attribute Registration Protocol.

VLAN ID

Specifies the VLAN to which the Ethernet frame belongs. A 12-bit field specifying the VLAN to which the Ethernet frame belongs. The hexadecimal values of 0x000 and 0xFFF are reserved. All other values may be used as VLAN identifiers, allowing up to 4094 VLANs. The reserved value 0x000 indicates that the frame does not belong to any VLAN; in this case, the 802.1Q tag specifies only a priority and is referred to as a priority tag. On bridges, VLAN 1 (the default VLAN ID) is often reserved for a management VLAN; this is vendor specific.

VLAN Priority

Sets the frame priority level. Otherwise known as Priority Code Point (PCP), VLAN Priority is a 3-bit field which refers to the IEEE 802.1p priority. It indicates the frame priority level. Values are from 0 (lowest) to 7 (highest).

Differentiated Services (6-bit DSCP value)

Provides quality of service if the DSCP protocol is supported on your network. Can be specified independently for SIP control packets versus RTP audio packets.

Advanced Settings Tab – Admin

The screenshot shows the 'Advanced Settings' tab with the 'Admin' sub-tab selected. The interface includes the following sections:

- Admin Password:** Fields for 'Password' and 'Confirmation', each with a 'Reset' icon.
- General:**
 - Device Name (Hostname): sipintercom
 - Introduction Section on Status Page: On Off
 - Web Interface Session Timeout: 1 hour (dropdown menu). Note: Automatically log out web interface after period of inactivity.
- Log Settings:**
 - Log Level: Error (Lowest) Notice ("Event") Info ("SIP") Debug (Highest)
 - Log Method: Local Network Both
 - Log Server: (empty text field)
- Management:**
 - Web Interface Protocol: Both HTTP and HTTPS HTTPS Only
 - Force Strong Password: Enabled Disabled
 - Allow Secure SIP Passwords: Enabled Disabled. Note: After enabling this option, it is recommended to re-enter SIP passwords and their corresponding realm to store the passwords securely.
 - SNMP Support (v1 get only): Enabled Disabled

A 'Save' button with a green checkmark is located at the bottom right of the form.

Password

Password to log into the 8201 SIP PoE Intercom web interface. You should change the default password **algo** in order to secure the device on the network. If you have forgotten your password, you will need to perform a reset using the Reset Button in order to restore the password (as well as all other settings) back to the original factory default conditions.

For additional password security see "Force Strong Password" below.

Confirmation

Re-enter network admin password

Device Name (Hostname)

Name to identify the device in the Algo Network Device Locator Tool.

Introduction Section on Status Page

Allows the introduction text to be hidden from the login screen.

Web Interface Session Timeout

Set the maximum period of inactivity after which the web interface will log out automatically.

Log Level

Use on the advice of Algo technical support only.

Log Method

Allows the 8201 SIP PoE Intercom to write to external Syslog server if the option for external (or both) is selected.

Log Server

If "Network" or "Both" is selected this is the address of the Syslog server on the network.

Web Interface Protocol

HTTPS is always enabled on the device. Use this setting to disable HTTP. When HTTP is disabled, requests will be automatically redirected to HTTPS. Also note that since the device can have any address on the local network, no security certificate exists, and thus most browsers will provide a warning when using HTTPS.

Force Strong Password

When enabled, ensures that a secure password is provided for the device's web interface for additional protection. The password requirements are:

- Must contain at least 10 characters
- Must contain at least 1 uppercase character
- Must contain at least 1 digit (0 – 9)
- Must contain at least 1 special character

Allow Secure SIP Password

Allows SIP passwords to be stored in the configuration file in an encrypted format, to prevent viewing and recovery. Once enabled, the SIP "Realm" field should be entered and all the configured Authentication Password(s) must be re-entered in the Basic Settings > SIP tab, and any other locations where SIP extension have been configured, to save the encrypted password(s).

If the Realm is changed at a later time, all the passwords will also need to be re-entered again to save the passwords with the new encryption.

To obtain your SIP Realm information, contact your SIP Server administrator (or check the SIP log file for a registration attempt). The Realms may be the same or different for all the extensions used.

SNMP Support (v1 get only)

Additional SNMP support is anticipated for future, but the 8201 SIP PoE Intercom will respond to a simple status query for automated supervision. Contact Algo technical support for more information.

Advanced Settings Tab – Time

Network time is used for logging events into memory for troubleshooting.

Timezone

Select timezone.

NTP Time Servers 1/2/3/4

The interface will attempt to use Timer Server 1 and work down the list if one or more of the time servers become unresponsive.

NTP Time Server Source

When "Use DHCP Option 42" is chosen, if an NTP Server address is provided via the DHCP Option 42, that NTP Server will be used instead of the 4 mentioned above. Alternatively, "Ignore DHCP Option 42" can be chosen to only use servers mentioned above.

Device Date/Time

This field shows the current time and date as set on the device. If testing the device on a lab network that may not have access to an external NTP server, the "Sync with browser" button can be used to temporarily set the time on the device.

Note, this time value will be lost at power down, or overwritten if NTP is currently active. Time and date are used only for logging purposes and are not typically required.

Advanced Settings Tab – Provisioning

The screenshot shows the 'Provisioning Settings' page. At the top, there are navigation tabs: Status, Basic Settings, Additional Features, **Advanced Settings**, System, and Logout. Below these are sub-tabs: Network, Admin, Time, **Provisioning**, Tones, Advanced SIP, and Advanced Multicast. The main content area is titled 'Provisioning Settings' and contains the following sections:

- Mode:** A section with a 'Provisioning Mode' label and two radio buttons: 'Enabled' (selected) and 'Disabled'.
- Settings:** A section containing:
 - Server Method:** Radio buttons for 'Auto (DHCP Option 66/160/150)', 'DHCP Option 66 only', 'DHCP Option 160 only', 'DHCP Option 150 only', and 'Static' (selected). A small information icon is present next to the 'Auto' option with the text: 'Auto mode automatically checks all 3 DHCP options for an active provisioning server, in the order listed.'
 - Static Server:** A text input field.
 - Download Method:** Radio buttons for 'TFTP', 'FTP', 'HTTP' (selected), and 'HTTPS'.
 - Auth User Name:** A text input field.
 - Auth Password:** A text input field with a small eye icon for toggling visibility.
 - Config Download Path:** A text input field.
 - Firmware Download Path:** A text input field.

At the bottom right of the form, there is a 'Save' button with a green checkmark icon.

Note: It is recommended that Provisioning Mode be set to Disabled if this feature is not in use. This will prevent unauthorized re-configuration of the device if DHCP is used.

Provisioning allows installers to pre-configure 8201 SIP PoE Intercom units prior to installation on a network. It is typically used for large deployments to save time and ensure consistent setups.

The device can be provisioned via the Auto mode (where all three DHCP options (Option 66/160/150) will be automatically checked for an active provisioning server), just one of the three specified DHCP options, or a Static Server. In addition, there are four different ways to download provisioning files from a "Provisioning Server": TFTP (Trivial File Transfer Protocol), FTP, HTTP, or HTTPS.

For example, 8201 configuration files can be automatically downloaded from a TFTP server using DHCP Option 66.

This option code (when set) supplies a TFTP boot server address to the DHCP client to boot from.

DHCP must be enabled if using DHCP Option 66/160/150, in order for Provisioning to work.

One of two files can be uploaded on the Provisioning Server (for access via TFTP, FTP, HTTP, or HTTPS):

Generic (for all 8201 Paging Adaptors)	algop8201.conf
Specific (for a specific MAC address)	algom[MAC].conf

MD5 Checksum

In addition to the .conf file, an .md5 checksum file must also be uploaded to the Provisioning server. This checksum file is used to verify that the .conf file is transferred correctly without error.

A tool such as can be found at the website address below may be used to generate this file: <http://www.fourmilab.ch/md5>

The application doesn't need an installation. To use the tool, simply unzip and run the application (md5) from a command prompt. The proper .md5 file will be generated in the same directory.

If using the above tool, be sure to use the "-l" parameter to generate lower case letters.

Generating a generic configuration file

1. Connect 8201 to the network
2. Access the 8201 Web Interface Control Panel
3. Configure the 8201 with desired options
4. Click on the System tab and then Maintenance.
5. Click "Download" to download the current configuration file
6. Save the file settings.txt
7. Rename file settings.txt to algop8201.conf
8. File algop8201.conf can now be uploaded onto the Provisioning server

If using a generic configuration file, extensions and credentials have to be entered manually once the 8201 SIP PoE Intercom has automatically downloaded the configuration file.

Generating a specific configuration file

1. Follow steps 1 to 6 as listed in the section "Generating a generic configuration file".
2. Rename file settings.txt to algom[MAC address].conf (e.g. algom0022EE020009.conf)
3. File algom[MAC address].conf can now be uploaded on the Provisioning server.

The specific configuration file will only be downloaded by the 8201 SIP PoE Intercom with the MAC address specified in the configuration file name. Since all the necessary settings can be included in this file, the 8201 will be ready to work immediately after the configuration file is downloaded. The MAC address of each 8201 SIP PoE Intercom can be found on the back label of the unit.

For more Algo SIP endpoint provisioning information, see:
www.algosolutions.com/provision

Advanced Settings Tab – Tones

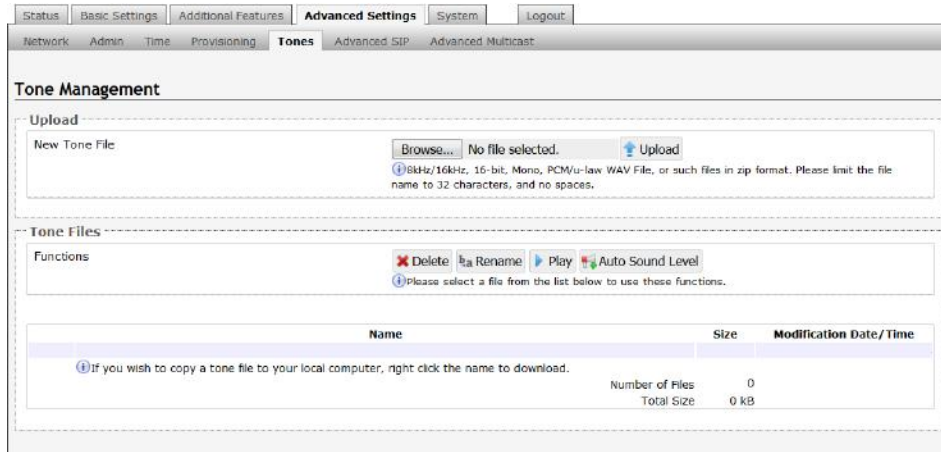

Uploading Custom Ring Tones (WAV Files)

Custom audio files (WAV format) may be uploaded into memory (1 GB) to play for notification applications.

An existing file may also be modified by downloading the original via the links in the web interface, making the desired changes, and then uploading the new version with a different name. Audio files must be in the following format:

- WAV format
- 8kHz or 16kHz sampling rate
- 16-bit PCM, or u-law
- Mono

A zip files containing one or more audio files may also be uploaded. File names must be limited to 32 characters, with no spaces.

Advanced Settings Tab – Advanced SIP

Outbound Proxy

IP address for outbound proxy. A proxy (server) stands between a private network and the internet.

STUN Server

IP address for STUN server if present.

Register Period (seconds)

Maximum requested period of time where the 8201 SIP PoE Intercom will re-register with the SIP server. Default setting is 3600 seconds (1 hour). Only change if instructed otherwise.

Keep-alive Method

If Double CRLF is selected the 8201 SIP PoE Intercom will send a packet every 30 seconds (unless changed) to maintain connection with the SIP Server if behind NAT.

Server Redundancy Feature

Two secondary SIP servers may be configured. The 8201 SIP PoE Intercom will attempt to register with the primary server but switch to a secondary server when necessary. The configuration allows re-registration to the primary server upon availability or to stay with a server until unresponsive.

If Server Redundancy is selected the web page will expand as shown below.

Backup Server #1

If primary server is unreachable the 8201 SIP PoE Intercom will attempt to register with the backup servers. If enabled, the 8201 SIP PoE Intercom will always attempt to register with the highest priority server.

Backup Server #2

If backup server #1 is unreachable the 8201 SIP PoE Intercom will attempt to register with the 2nd backup server. If enabled, the 8201 SIP PoE Intercom will always attempt to register with the highest priority server.

Polling Intervals (seconds)

Time period between sending monitoring packets to each server. Non-active servers are always polled, and active server may optionally be polled (see below).

Poll Active Server

Explicitly poll current server to monitor availability. May also be handled automatically by other regular events, so can be disabled to reduce network traffic.

Automatic Failback

Reconnect with higher priority server once available, even if backup connection is still fine.

Polling Method

SIP message used to poll servers to monitor availability.

Advanced Settings Tab – Advanced Multicast

Status Basic Settings Additional Features **Advanced Settings** System Logout

Network Admin Time Provisioning Tones Advanced SIP **Advanced Multicast**

Advanced Multicast Settings

Current multicast mode: Slave
Multicast mode can be set in "Basic Settings > Multicast"

Slave Settings

Audio Sync (milliseconds, 0 ~ 1000)

When using multicast with other third-party devices that have a delay in their audio path, the audio on the 8201 may be heard slightly earlier than on these other devices. Use this feature to add a small delay to the audio output on the 8201 in order to synchronize with these other devices. Applies to Multicast Slave mode only.

Basic Zone Definition

If using an Algo device as a Multicast master, it is recommended to set the slave tones to "None" to avoid conflicts, as the Algo devices already multicast a tone by default.

Zone	IP Address and Port	Page Tone	Page Volume
Priority Call (DTMF:9)	<input type="text" value="224.0.2.60:50000"/>	<None>	<Use Default Volume>
All Call (DTMF:0)	<input type="text" value="224.0.2.60:50001"/>	<None>	<Use Default Volume>
Zone 1 (DTMF:1)	<input type="text" value="224.0.2.60:50002"/>	<None>	<Use Default Volume>
Zone 2 (DTMF:2)	<input type="text" value="224.0.2.60:50003"/>	<None>	<Use Default Volume>
Zone 3 (DTMF:3)	<input type="text" value="224.0.2.60:50004"/>	<None>	<Use Default Volume>
Zone 4 (DTMF:4)	<input type="text" value="224.0.2.60:50005"/>	<None>	<Use Default Volume>
Zone 5 (DTMF:5)	<input type="text" value="224.0.2.60:50006"/>	<None>	<Use Default Volume>
Zone 6 (DTMF:6)	<input type="text" value="224.0.2.60:50007"/>	<None>	<Use Default Volume>
Music (DTMF:7)	<input type="text" value="224.0.2.60:50008"/>	<None>	<Use Default Volume>

Expanded Zone Definition

Zone	IP Address and Port	Page Tone	Page Volume
Zone 10 (DTMF: *10)	<input type="text" value="224.0.2.110:50000"/>	<None>	<Use Default Volume>
Zone 11 (DTMF: *11)	<input type="text" value="224.0.2.111:50000"/>	<None>	<Use Default Volume>

↓

Zone 50 (DTMF: *50)	<input type="text" value="224.0.2.150:50000"/>	<None>	<Use Default Volume>
---------------------	--	--------	----------------------

Audio Sync

When paging to the 8201 SIP PoE Intercom as well as other third party devices, the low latency of the 8201 may cause the audio to lead other devices. By adding audio delay up to one second, the 8201 may be synchronized with other endpoints or telephones that have greater latency.

Zone Definition

The “Expanded” Slave zones can be enabled/disabled in Basic Settings > Multicast. Default IP addresses and ports may be revised for any given zone in the table.

Note: Ensure that the Address and Port settings are the same for all master and slave devices.

Page Tone and Page Volume

When an Algo device is the multicast master, a page tone will play on the slave device, so it is recommended to set the slave tone to “None”. If a page is received from a non-Algo device that doesn’t send a tone, a tone can be inserted on the slaves (above) each time they detect page audio starting, allowing them to play a tone.

By default, the same page volume can be set for all slave zones in the Basic Settings > Features tab. Unique page volumes may be revised on a per-zone basis in the table above. For instance, emergency pages can be louder on certain slave speakers.

Status Basic Settings Additional Features **Advanced Settings** System Logout

Network Admin Time Provisioning Tones Advanced SIP **Advanced Multicast**

Advanced Multicast Settings

Current multicast mode: Slave
Multicast mode can be set in "Basic Settings > Multicast"

Slave Settings

Audio Sync (milliseconds, 0 ~ 1000)

When using multicast with other third-party devices that have a delay in their audio path, the audio on the 8201 may be heard slightly earlier than on these other devices. Use this feature to add a small delay to the audio output on the 8201 in order to synchronize with these other devices. Applies to Multicast Slave mode only.

Polycom Slave Tones

If using an Algo device as a Multicast master, it is recommended to set the slave tones to "None" to avoid conflicts, as the Algo devices already multicast a tone by default.

Group 1 <None>

Group 2 <None>

↓

Group 25 <None>

Save

Polycom Slave Tones

A tone may be set for any of the 25 Polycom Groups. If using an Algo device as a Multicast master, it is recommended to set the slave tones to "None" to avoid conflicts, as the Algo devices already multicast a tone by default.

These settings are available only if the 8201 is set as a Multicast Slave and "Polycom Group Page" or "Polycom Push-to-Talk" are selected in the Basic Settings > Multicast tab.

System Tab - Maintenance

The screenshot shows a web interface for system maintenance. At the top, there are navigation tabs: Status, Basic Settings, Additional Features, Advanced Settings, System (selected), and Logout. Below these are sub-tabs: Maintenance (selected), System Log, Credits, and About. The main content area is titled 'System Maintenance' and is divided into three sections: 1. 'Backup / Restore Configuration' with options to 'Download Configuration File' (Download button), 'Restore Configuration File' (Browse... button, No file selected., Restore button), and 'Restore Configuration to Defaults' (Restore Defaults button). 2. 'Reboot' with a 'Reboot the device' label and a Reboot button. 3. 'Upgrade to New Firmware' with radio buttons for 'From Local Files' (selected) and 'From URL', and fields for 'Firmware Image' (Browse... button, No file selected.) and 'MD5 Checksum' (Browse... button, No file selected.), followed by an Upgrade button.

Download Configuration File

Save the device settings to a text file for backup or to setup a provisioning configuration file.

Restore Configuration File

Restore settings from a backup file.

Restore Configuration to Defaults

Resets all 8201 SIP PoE Intercom device settings to factory default values.

Reboot the Device

Reboots the device.

Method

Specify whether the firmware files will be downloaded from the local computer or a remote URL.

Firmware Image

Point to the firmware image provided by Algo

MD5 Checksum

Point to the checksum file provided by Algo

Upgrade 8201 SIP PoE Intercom Firmware

1. From the top menu, click on System.
2. In the Upgrade section, click on Choose File and select the 8201 SIP PoE Intercom firmware file to upload. Note that both the FW firmware and MD5 checksum files must be loaded.
3. Click Upgrade
4. After the upgrade is complete, confirm that the firmware version has changed (refer to top right of Control Panel).

System – System Log

System log files are automatically created and assist with troubleshooting in the event the 8201 SIP PoE Intercom does not behave as expected.

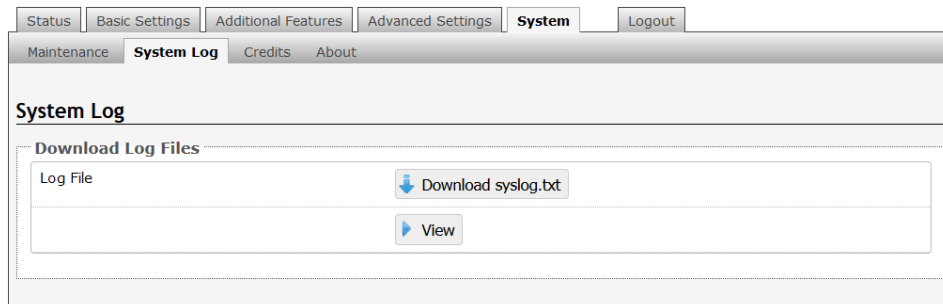

Specifications

- Power Input:** 48 V PoE IEEE 802.3af Class 0
(Max 6 W - Idle nominal 2 W)
- Dimensions:** 4.5" x 4.5" x 1.34" (115 mm x 115 mm x 34 mm)

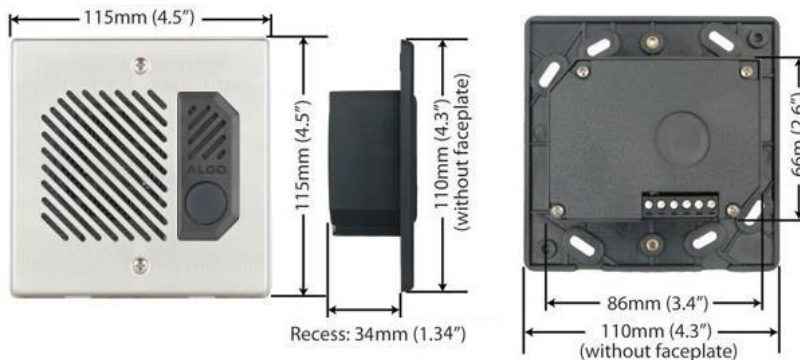

- Weight:** 0.90 lb (.41kg)
- Audio Codecs:** G.711 A-law, G.711 u-law, G.722
- Server Redundancy:** Primary, secondary, tertiary
- Processor:** Linux OS
ARM Cortex-A8 32-Bit RISC Processor
- Relay Output:** Normally open or normally closed.
Max rating 30 V 50 mA
- Relay Input:** Normally open or normally closed dry contact.
- Configuration:** Web interface (HTTP or HTTPS) or auto-provisioning server
- Provisioning:** TFTP, FTP, or HTTP
- NAT:** STUN, CRLF Keep Alive
- Environmental:** -40 to 104 deg F (-40 + 40 degC)
10-95% RH non-condensing.
- Compliance:** EN60950:2001, IEEE 802.3-2008, RFC3261, RoHS, CE, FCC Class A, CISPR 22 Class A, CISPR 24, CSA/UL (USA & Canada)

8061 IP Relay Controller

The 8201 can provide secure door control functionality when used with the optional Algo 8061 IP Relay Controller.

The 8061 serves as a bridge between the 8201 and peripheral hardware such as door strikes, door sensors, door bells, etc.

As a door opening controller, the 8061 can be located in a secure environment to prevent tampering by outside visitors.

The 8201's PoE network connection also provides additional security over internal relay wires that can be used to unlock the door if the device is tampered with.

The door control feature is activated by a command from the answering telephone keypad, or entry of the door release code by a visitor.

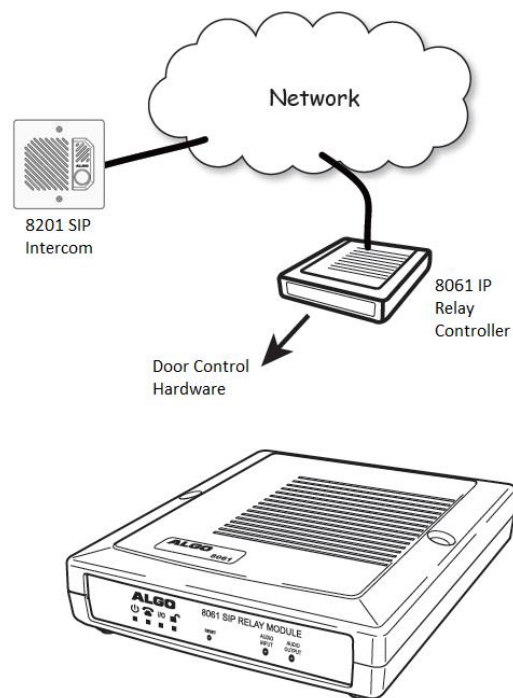

Typical 8201/8061 Setup

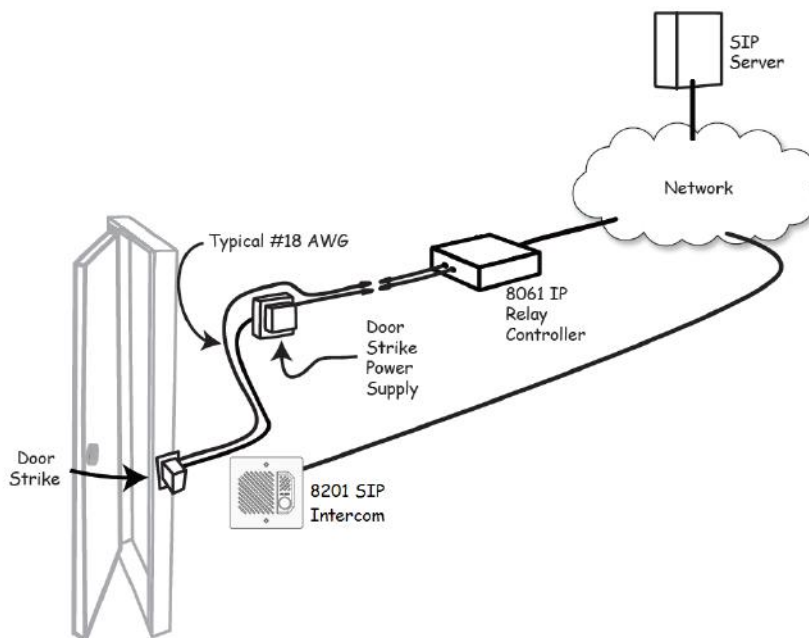

PoE and Relay Connections on back of 8061 IP Relay Controller:

1. Connect the 8061 to the network via an Ethernet cable at the back of the device. Ensure that a PoE port is used for power and that the 8061 is connected to the same subnet and VLAN as the target intercom.
2. Run two wires from the door strike to the Normally Open/Common (NO/C) input pair or Common/Normally Closer (C/NC) input pair on the 8061. For more wiring information please visit: www.algosolutions.com/doorstrike.

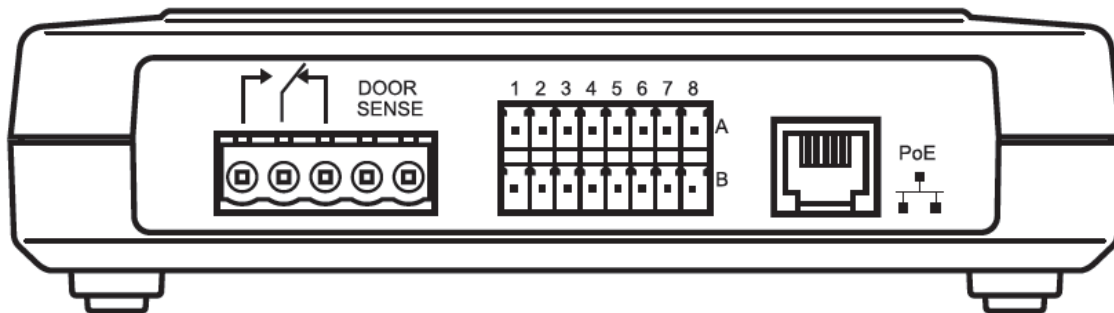

Configuring the 8061

1. Find the IP address of the Algo 8061 using the Algo locator tool available from the Algo website (www.algosolutions.com/locator). This tool displays all of the Algo devices available on the network, and their corresponding IP addresses. Note this address down as you will need it when you configure the 8201 for use with this device.
2. Point your browser to the above IP address. The 8061 Control Panel will be displayed.
3. Log in. The default password is **algo**.
4. Go to the **Basic Settings > Door Control** tab.

The screenshot shows the ALGO web interface with the following structure:

- Top navigation: Status, **Basic Settings**, Advanced Settings, System, Logout
- Sub-navigation: SIP, Input, Events, **Door Control**
- Section: **Door Relay Settings**
- Form fields:
 - Door Relay Control Link: Enabled Disabled
 - Door Control Password: [Reset icon]
- Bottom right: (with a green checkmark icon)

5. Set the "Door Control Link" to "Enabled".
6. In the "Door Control Password" field set a password that will be used for configuring the intercom for door control. Note this password down as you will be reusing it when configuring the 8039 with this device.

See section "Basic Settings Tab – Door Control" page 20 for configuring the 8201 with the parameters from above.

FCC Compliance Statement

This equipment has been tested and found to comply with the limits for a Class A digital device, pursuant to Part 15 of the FCC Rules. These limits are designed to provide reasonable protection against harmful interference when the equipment is operated in a commercial environment. This equipment generates, uses, and can radiate radio frequency energy, and if it is not installed and used in accordance with the instruction manual, it may cause harmful interference to radio communications. Operation of this equipment in a residential area is likely to cause harmful interference, in which case the user will be required to correct the interference at his own expense.