

8036 SIP Multimedia Intercom Install Guide

This sheet will guide you with the physical installation of your new 8036 SIP Multimedia Intercom.

For full product documentation, including configuration, SIP registration, and application development, please visit www.algosolutions.com/8036docs

What's Included

- 8036 SIP Multimedia Intercom (includes assembled main housing, removable Front Bezel, Surface Mount Bracket, Algo Logo Badge, and Security Screw)
- Drywall Bracket
- Mounting Gasket
- Algo Security Tool
- Six #8 x 1.5" Type A Pan Head Phillips Screws
- Six #8 x 1" Type B Pan Head Phillips Screws
- Ethernet Cable Boot

Wall Mounting

The 8036 can be either surface or flush mounted. The unit is designed to shed rainwater and allow air ventilation only when oriented in the correct position (ALGO logo at top) and installed vertically.

Removal of Front Bezel for Installation

The 8036 is shipped partially assembled and must be partially disassembled before it can be installed.

Remove the security screw behind the ALGO Logo Badge by first pressing on one side of the badge. This will raise the other side so that it can be removed easily by hand.

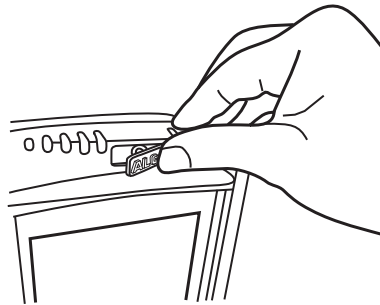

A security bit ("Algo Security Tool") is included with the 8036 that fits standard socket screwdrivers. Use the bit in a screwdriver to remove the security screw and carefully remove the Front Bezel by pulling at the top and then disengaging the bottom clip.

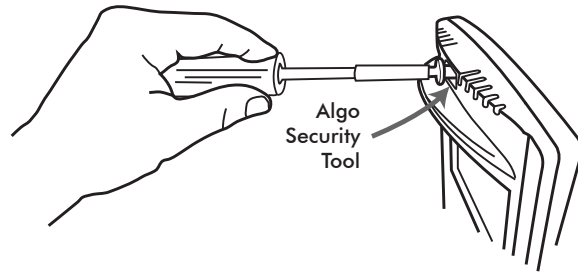
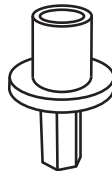

Put the Front Bezel, Security Screw, and Logo Badge aside for re-assembly after mounting.

Flush Mounting into Drywall (Interior)

1. Create a drywall cut out per the template on page 4 of this sheet.
2. Place the Drywall Bracket into wall and bend tabs around to the front of the drywall to hold in place.
3. After connecting the Ethernet cable, use the #8 x 1.5" Type A Pan Head screws to secure the 8036 housing to the Drywall Bracket.
4. Replace the Front Bezel and keep the Algo Security Tool in a safe location.
5. Replace the ALGO Logo Badge.



The Mounting Gasket and Surface Mount Bracket are not required for drywall mounting.

Flush mounting the 8036 on inside drywall

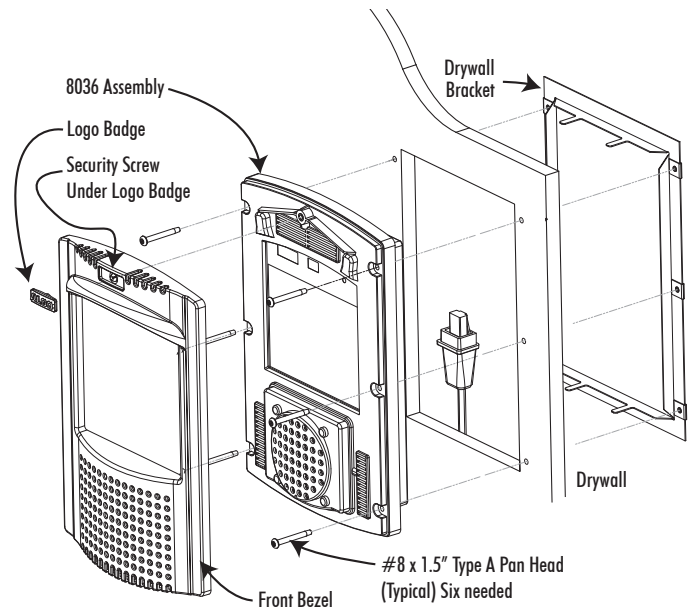

ALGO
Communication Solutions

Algo Communication Products Ltd.
4500 Beedie Street
Burnaby, BC Canada V5J 5L2
www.algosolutions.com

Flush Mounting into Other Materials or Outdoors

The same guidelines of flush mounting from the previous section apply, however, the Drywall Bracket may not be required if the wall material is firm enough to hold a screw close to the cutout edge. A #8 anchor may be required (not supplied) for the wall material.

If outdoors:

1. A rubber Ethernet Cable boot is supplied to be placed over the network cable prior to terminating with a plug (see "Network Connection" on page 3).
2. While the 8036 is designed to withstand rain, it may be undesirable for water to enter the wall cavity. This can be achieved by sealing the cable hole prior to mounting or using the Mounting Gasket between the 8036 and wall. Uneven surfaces may require a silicon bead around the 8036 after installation.

Flush mounting into an outside wall

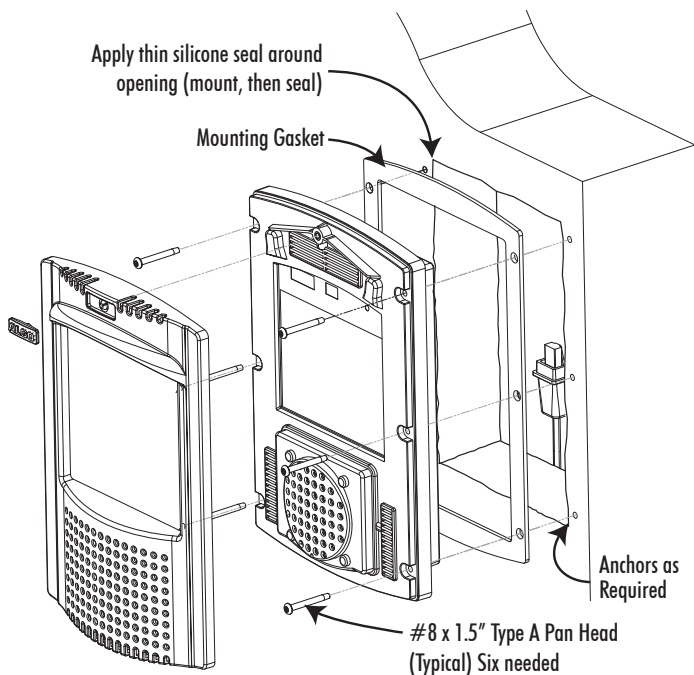

Surface Mounting

The Surface Mount Bracket may be used on a wall surface where flush mounting is undesirable, or not practical. The bracket also may be good option when integrating the 8036 into stonework.

1. Mount the Surface Mount Bracket using the #8 x 1.5" Type A Pan Head screws supplied. For some wall materials, #8 anchors may be required (not included).



There is a top and bottom to the Surface Mount Bracket. Make sure the two drainage holes are at the bottom.

If outdoors:

- a. Ensure any opening in the wall is sealed or apply a silicon bead between the Surface Mount Bracket and wall surface around the outside perimeter.
 - b. The Ethernet Cable Boot is to be placed over the network cable prior to terminating with a plug (see "Network Connection" on page 3).
 - c. To prevent water from getting behind the 8036, place the Mounting Gasket on to the back of the 8036 housing prior to mounting.
2. After connecting the Ethernet cable, use the #8 x 1" Type B Pan Head screws to secure the 8036 housing to the Surface Mount Bracket.
 3. Replace the Front Bezel and keep the Algo Security Tool in a safe location. Replace the ALGO Logo Badge.



The Drywall Bracket is not required when surface mounting.

Surface mounting on outside wall

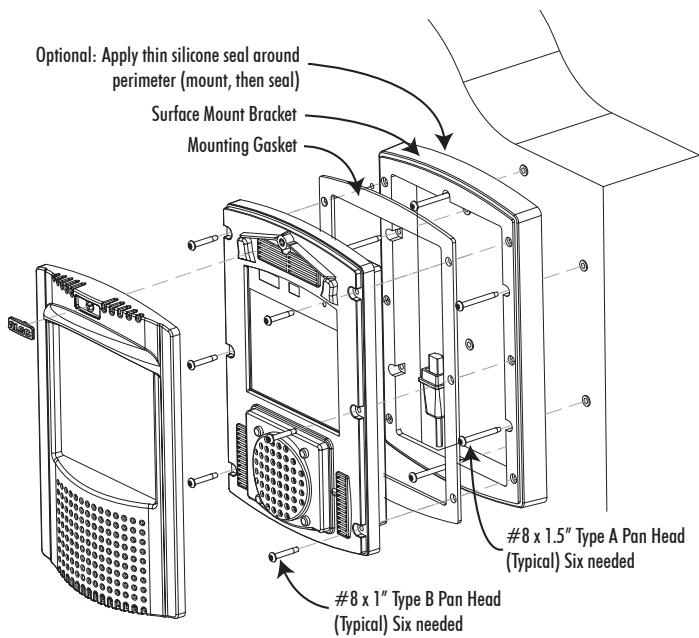

Mounting Height

For most applications, a mounting height of approximately 55 inches (1.4 m) from floor to center of display is recommended.

Mounting the 8036 at the proper height

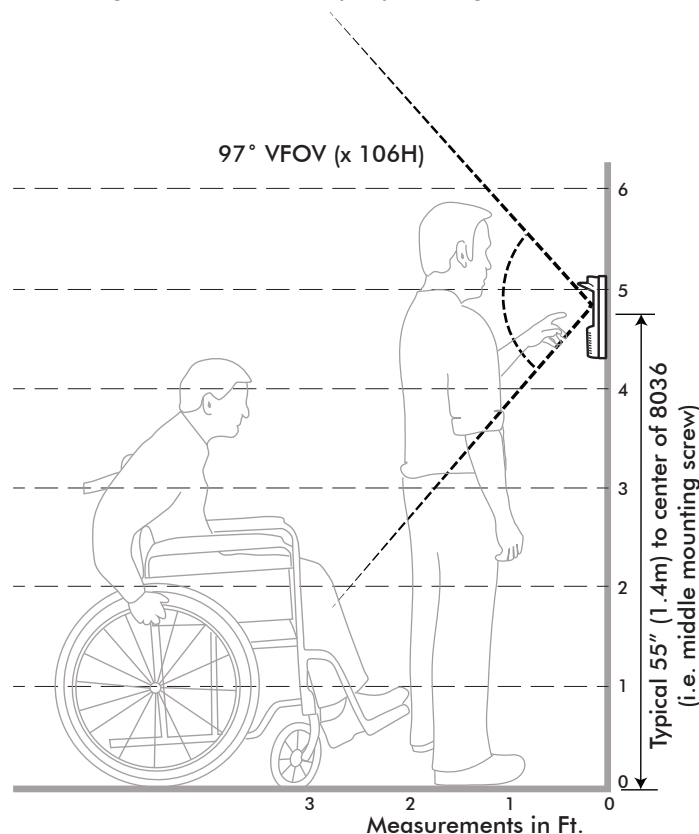

Network Connection

The 8036 is powered by the Ethernet PoE network connection. Typically a network cable is run to the 8036 location and then terminated with a male RJ45 plug.

If mounting outdoors, slide the Ethernet Cable Boot onto the cable before installing the RJ45 plug.

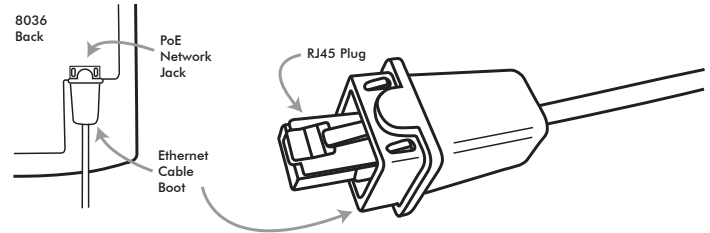

After inserting the plug into the 8036 jack, carefully position the boot into the jack cavity to prevent moisture or insects from getting inside.



When inserting the plug into the jack, be sure the plug lock tab is not accidentally depressed, creating a loose connection.

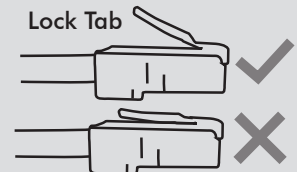

Regulatory Information



The 8036 SIP Multimedia Intercom is designed and tested to comply with EN 60950-1:2006 safety requirements. When the unit is connected to wiring that exits the building, there is potential risk of lightning induced electrical surges or high voltages from fault conditions.

To reduce risk, outdoor wiring should be protected by Earth grounded conduit whenever possible. The 8036 is a Power over Ethernet (PoE) device. The PoE power source must be a Limited Power Source (LPS), provided by CAT5 UTP cable, and isolated from mains by minimum reinforced or double insulation. Ensure that the PoE injector or PoE enabled switch carries safety regulatory approval marks (ie CSA, UL, CE).

HOLE CUTOUT SIZE FOR FLUSH MOUNT INSTALLATION

This hole template is also available online at
www.algosolutions.com/8036mounting

← Cutout along
solid black line

Scale Check

1"



5 cm

ALGO
Communication Solutions