



Table of contents (目录)

1. 封面 Cover	1
2. 目录 Catalogue	2
3. 修订记录 Revision record.....	2
4. 产品描述 Product description.....	3
5. 兼容话机 Compatible to IP phone.....	3
6. 功能特性 Functional characteristic.....	3
7. 连接方式 Connection Type.....	3
8. 图纸 Drawing.....	4
9. 环境条件 Environmental condition.....	5
10. 包装 Packaging.....	5

4 产品描述 Product description:

EHS 20 远程控制适配器可运用于无线耳机连接 Fanvil IP 话机实现远程接听、挂断电话。
Connect DECT base to Fanvil IP phone with EHS20 adaptor in order to achieve remote control and allow users to answer and end the calls by press the multi-function button on headset

5 Compatible to IP phone:

Fanvil X2/X2P IP Phone
X3S/X3SP/X3G IP Phone
X4/X4G IP Phone
X5S IP Phone
X6 IP Phone

6 功能特性 Functional characteristic:

来电响铃 Hear ring tones
接听电话 Answer calls
结束电话 End calls
麦克风静音 Mute the microphone

7 连接方式 Connection Type:



8 Drawing (图纸)

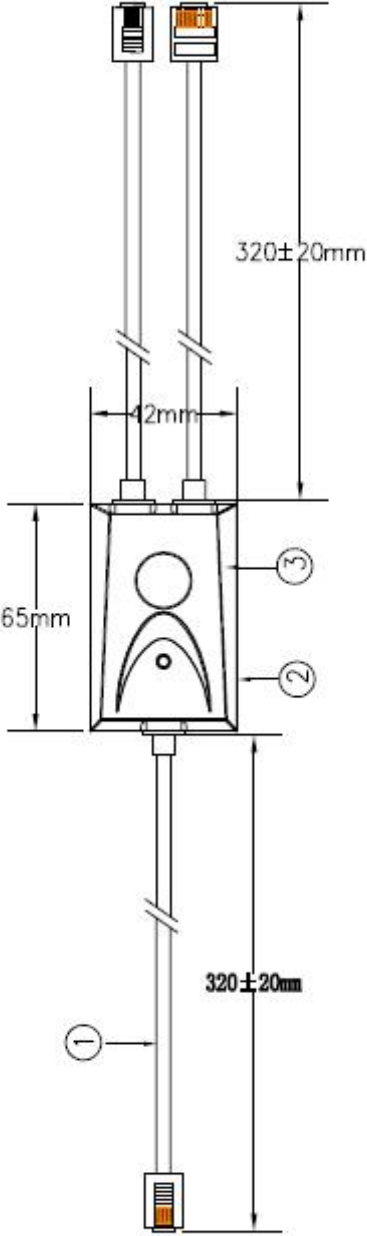

9 环境条件 Environmental condition:

存储环境 Storage Environment: -20°C — $+60^{\circ}\text{C}$ 相对湿度小于 85%无冷凝
 -20°C — $+60^{\circ}\text{C}$ Relative humidity less than 85% without condensation

工作环境 Working environment: 0°C ~ — $+40^{\circ}\text{C}$ 相对湿度小于 85%无冷凝
 0°C ~ — $+40^{\circ}\text{C}$ Relative humidity less than 85% without condensation

10 Packing (包装)

