

SMARTNODE INTEGRATED ACCESS

A Guide to Patton's Millennial-Generation Converged CPE

SmartNode™ IAD Integrated Access Product & Solutions Guide

In this Guide

CPE Customer Premise Equipment
IAD Integrated Access Devices
ISR Integrated Services Routers
EAD Ethernet Access Devices

EoC Ethernet Over Copper Devices
MSAR Multiservice Access Routers
MSBR Multiservice Business Routers
xDSL All Generations of DSL Transmission Technology



Contents

What is a SmartNode™?	3	Converged Voice & Data Managed Services	20
Device Portfolios	4	Branch Office Managed Voice & Data	20
VDSL/ADSL Devices Portfolio	4	Multi-Box or One-Box CPE?	22
G.SDSL Devices Portfolio	5	CPE-to-CPE Ethernet Extenders	25
Ethernet & Fiber Devices Portfolio	5	Ethernet Aggregation	26
At-A-Glance	6	Ethernet Extension Topologies & Use Cases	27
Product Line Summary	7	Point-to-Point	27
VDSL2/ADSL2+ Converged CPE/IAD Products	7	Star	27
G.SHDSL Converged CPE/IAD Products	8	Multi-Drop Ethernet (MDE)	28
Ethernet-over-Fiber Converged CPE/IAD Products	9	Star + Multi-Drop Ethernet	28
VDSL2/ADSL2+ Modem/Bridge/Router Products	10	Ring (with MDE)	29
G.SHDSL Modem/Bridge/Router Products	10	Long Reach Power over Ethernet	29
SmartNode CPE/IAD Unique Values	11	VoIP IAD Products	30
IAD Product Tables	12	SmartNode™ 5570 Series eSBC Router/IAD	30
VDSL/ADSL Devices	12	SmartNode™ 5551 eSBC Router/IAD	31
G.SHDSL Devices	12	SmartNode™ 5540 Series eSBC Router/IAD	32
Ethernet Devices	14	SmartNode™ 5530 Series eSBC Router/IAD	33
Fiber Devices	14	SmartNode™ 5501 eSBC Router/IAD	34
VDSL2 Performance Innovations	16	SmartNode™ 5490 eSBC Router/IAD	35
VDSL2 Vectoring	16	SmartNode™ 5300 eSBC Router/IAD	36
How VDSL2 Vectoring Works	16	SmartNode™ 4990 Multiport Enterprise IAD	38
VDSL2 Profiles	17	EFM IAD, Bridge, Router & CPE Products	40
ADSL Performance Enhancements	18	OnSite™ 3300 G.SHDSL.bis EFM IAD	40
xDSL Performance Comparisons	18	OnSite™ 3201 & 3241 G.SHDSL High-Speed Routers	42
G.SHDSL Performance Innovations	19	OnSite™ 3088A G.SHDSL CPE	43
Solution Considerations	20	OnSite™ 2300 G.SHDSL.bis EFM CPE	44
SIP Trunking	20	OnSite™ 2201 VDSL2/ADSL2+ Router	45
Hosted Telephony	20	OnSite™ 1069 VDSL2 100-Mbps Bridge	46

Copyright and Trademark Statement

Copyright © 2017 Patton Electronics Co. All rights reserved.

Patton is a registered trademark and the terms CopperLink, OnSite, SmartNode, and Trinity are trademarks of Patton Electronics Company in the United States and other countries.

What is a SmartNode?

Many people hastily refer to these products as VoIP Gateways or “ATAs” because some of the units come with analog or other legacy telephony interfaces. But, the fact is a SmartNode is so much more.

When our artists were trying to create an infographic, they interviewed FAEs and customers on how they are using the product. One helpful person pointed to the various Visio icons used to represent various networking and communication

functions. Below is what the artists created; noting that *calling a SmartNode a VoIP Gateway is like saying Bruno Mars plays drums or Prince played guitar.*

At the heart of any SmartNode is the software we call Trinity. Trinity software is extensible into a wide variety of purpose-built hardware, off-the-shelf hardware, virtualizable and available as a Cloud service. The focus of this guide is devices that **access network termination/demarc** or a **service termination** or both.

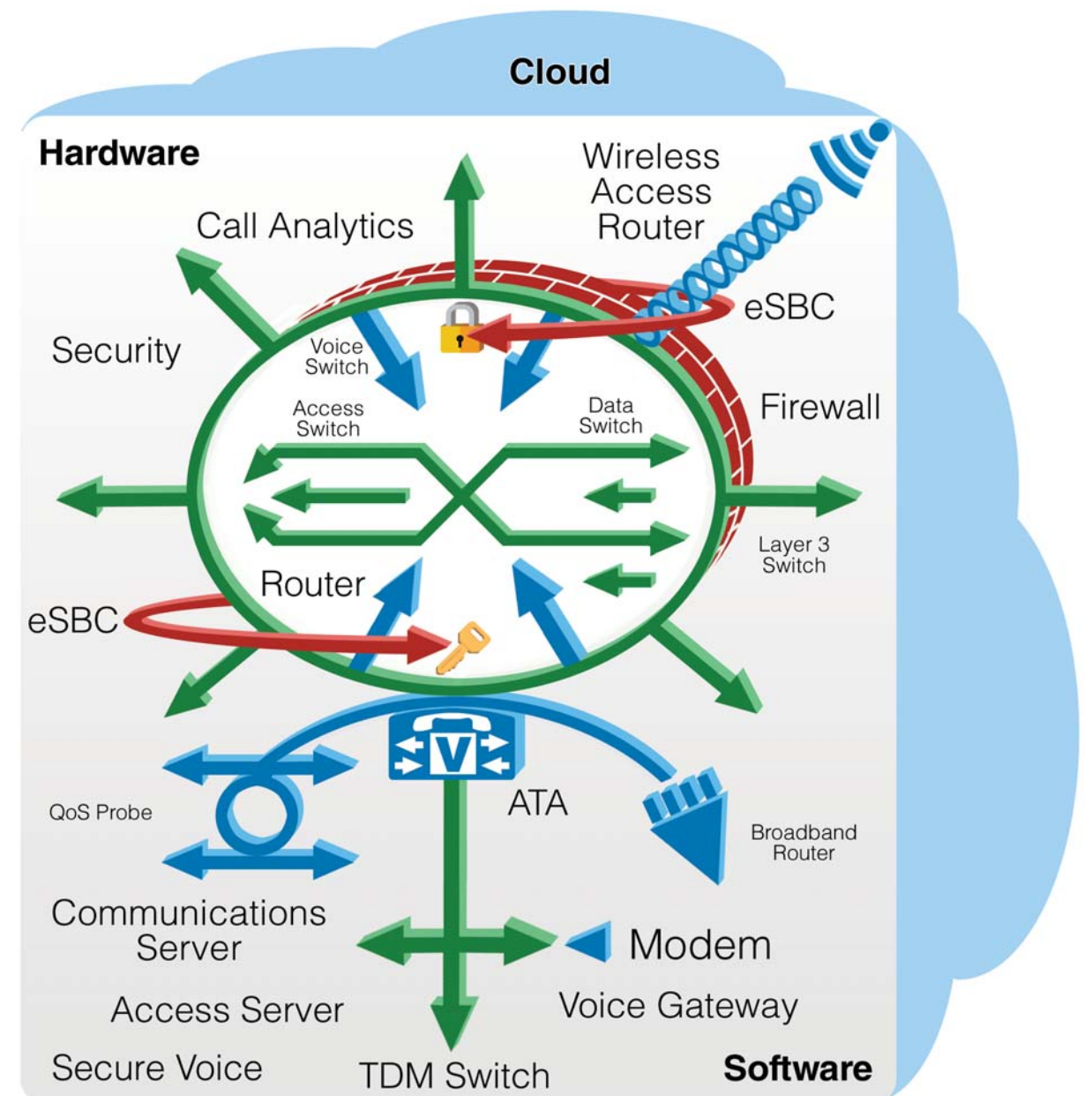







If a picture paints a thousand words, a thousand pictures paint a SmartNode.





Device Portfolios

Patton's SmartNode IAD device portfolio includes everything from a basic DSL modem to a fully survivable, multi-service access router supporting SIP SBC, converged voice and data security, and legacy telephony. Shown from the perspective of the access termination (ADSL, VDSL, G.SHDSL, fiber, and plain Ethernet) these portfolio maps are intended to guide you to the root model for further study.



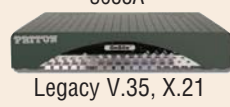

VDSL/ADSL Devices Portfolio

 <p>SN5570 Up to 2 PRI ports</p> <p>SN4990 Up to 4 PRI ports</p>	Modems with eSBC, TDM Voice, and Survivability
 <p>SN5540 2-8 FXS ports</p> <p>SN5550 Includes mixed FXS and BRI ports</p> <p>SN5530 Up to 8 BRI ports</p>	
 <p>SN5500 Up to 192 SIP sessions</p>	
 <p>SN5490 Up to 192 SIP sessions</p>	Modems with eSBC and Survivability
 <p>OS2201 Business class router</p>	Modem with Routing
 <p>1069 4 Ethernet ports</p>	Modem with Bridging

G.SDSL Devices Portfolio

 <p>SN4990 Up to 4 PRI ports</p> <p>SN5570 1-2 PRI ports</p>	Modems with eSBC, TDM Voice, and Survivability
 <p>SN5550 Up to 8 BRI ports</p> <p>SN5540 Includes mixed FXS and BRI ports</p> <p>SN5530 Includes 2-8 FXS ports</p>	
 <p>SN5500 Up to 192 SIP sessions</p> <p>SN5490 Up to 90 SIP sessions</p> <p>SN5300 Up to 70 SIP sessions</p>	
 <p>OS3300 All-IP, SIP eSBC Optional</p>	Modem with Routing and Survivability
 <p>3241 IP, ATM, HDLC and Frame Relay</p>	Modem with Bridging and Routing
 <p>3088A Legacy V.35, X.21 and E1 WAN</p>	TDM Modem

Ethernet & Fiber Devices Portfolio

 <p>SN4990 Up to 4 PRI ports</p> <p>SN5570 1-2 PRI ports</p>	Modems with eSBC, TDM Voice, and Survivability
 <p>SN5550 Up to 8 BRI ports</p> <p>SN5540 Includes mixed FXS and BRI ports</p> <p>SN5530 Includes 2-8 FXS ports</p>	
 <p>SN5500 Up to 192 SIP sessions</p> <p>SN5490 Up to 192 SIP sessions</p>	
 <p>SN5300 Up to 70 SIP sessions</p>	Modems with Routing, eSBC, and Survivability

At-A-Glance

This generation of Patton's SmartNode products offers a variety of partially and fully integrated CPE products for carriers and service providers migrating subscribers to modern Cloud-based services. Integrated with a wide range of WAN access technologies, these low-cost devices bring both legacy TDM interfaces, SIP voice together with survivability and state-of-the-art converged voice and data security.

- Perfectly designed CPE for SIP trunking, hosted telephony & Cloud services
- Scaled to accommodate service provider ALL-IP migration strategies
- The perfect scale and cost for branch office, SME and SOHO subscribers
- The most assured and safe voice & data security
- Automated, touch-less and secure provisioning
- QoS, QoE and quality real-time monitoring
- Fully automated multi-WAN, 3G/4G/LTE and TDM survivability

SmartNode IAD Product Comparisons									
Comparison		Converged CPE Products					ALL-IP Products		
		SN5530	SN5540	SN5550	SN5570	SN4990	SN5300	SN5490	SN5501
Page number		7, 8, 9	7, 8, 9	7, 8, 9	7, 8, 9	7, 8, 9	8, 9	7, 8, 9, 10	10
WAN	IP WAN Access/Trunks	Native 10/100/1000 Ethernet WAN							
		ADSL2+/VDSL2 with vectoring							
		G.SHDSL, 2, 4, 8 wire with bonding							
		SFP Fiber							
	TDM WAN Access/Trunks		✓	✓	✓	✓	✓		
Max. # of IP WAN Access Ports		Up to 4				Up to 3	Up to 4		
LAN	Ethernet	10/100/1000							
	Wi-Fi	✓	✓	✓	✓		✓	✓	✓
VoIP/SIP	SIP Session (eSBC Capacity)	200	200	200	200	80	60	80	200
	Transcoding	✓	✓	✓	✓	✓		✓	✓
TDM	TDM Interfaces	2-8 BRI	2-8 FXS	2-4 BRI + 2-4 FXS	2 x T1/E1/PRI	1-4 T1/E1/PRI			
	Max. Voice Channels	16	8	12	30	120			
Data	Layer 3 Routing	✓	✓	✓	✓	✓	✓	✓	✓
	Firewall	✓	✓	✓	✓	✓	✓	✓	✓
	VPN	✓	✓	✓	✓	✓	✓	✓	✓
	QoS (Queueing & Tagging)	✓	✓	✓	✓	✓	✓	✓	✓
	DHCP Server	✓	✓	✓	✓	✓	✓	✓	✓
Survivability	Multi-WAN	✓	✓	✓	✓	✓	✓	✓	✓
	3G/4G Back-Up	✓	✓	✓	✓		✓	✓	✓
	TDM/PSTN Survivability	✓	✓	✓	✓	✓			
Cloud Connected	Patton Cloud	✓	✓	✓	✓	✓	✓	✓	✓
	3rd Party Cloud	✓	✓	✓	✓	✓	✓	✓	✓
Management OA&M		CLI, Web-GUI, Telnet, SSH, RFTP, SNTP, SNMP, RADIUS, TACACS+, TR-069, EMS, HTTP, HTTPS, Touchless Provisioning and Automated Updates							
Troubleshooting		Call quality information logging and local storage, Test call functionality (SIP, ISDN, FXS, FXO), real time analyzes monitors for voice, network, management etc., CLI diagnose and statistics, Syslog, SNMP traps, SMS & e-mail notification through cloud notification, Wireshark packet capture.							

Note: Modem, bridge, and router-only products are not shown in this table (see pages 10 & 12).

Product Line Summary

Patton's Millennial-Generation Converged CPE products represent the newest state-of-the art multi-service access technology for service providers. The SmartNode brand is now extended to include the highest performance and most comprehensive set of hardware, software and cloud-integrations for access on the planet. These devices support a wide range of services over a wide variety of access networks. We support legacy DSL infrastructure, advanced vectoring and wire-bonding technologies for fiber-like performance over legacy copper, as well as fiber FTTX access. The SmartNode is now and again unrivalled in the world of telecom.

Referred to as IADs, EADs, EoCs, MSARs or MSBRs by different vendors you get the point; these products deliver multiple service to the customer premise delivering access in a tightly integrated low-cost platform for business customers.

VDSL2/ADSL2+ Converged CPE/IAD Products

Patton's VDSL2/ADSL2+ Converged CPE products are available in "All-IP" hardware configurations or with a variety of analog (FXS), BRI, and T1/E1/PRI telephony and network interfaces. All models provide access network and service termination and demarcation, and include edge routing, voice, and data security as well as enterprise session border controller functions.

All units include:

- 2 x 10/100/100 Ethernet LAN or WAN
- SIP eSBC licenses
- Transcoded SIP to SIP calls
- Multi-WAN IP failover and load balancing
- CLI, Web, and TR-069 configuration and management

VDSL2/ADSL2+ ALL-IP SIP eSBC Router/IAD



- 2 x 10/100/1000 Ethernet (LAN & WAN)
- Up to 128 SIP sessions without transcoding
- Up to 64 simultaneous transcoding channels

VDSL2/ADSL2+ FXS+BRI, SIP eSBC Router/IAD



- 2-4 BRI, 2-4 FXS, 2 FXS + 2 BRI or 4 FXS+ 4 BRI (8 TDM calls)
- USB for 3G/4G IP failover & load balancing

VDSL2/ADSL2+ BRI SIP eSBC Router/IAD



- 2-8 BRI
- USB for 3G/4G IP failover & load balancing

VDSL2/ADSL2+ T1/E1/PRI, SIP eSBC Router/IAD



- 2 x T1/E1/PRI (30 calls)
- TDM failover using 2nd T1/E1 port
- USB for 3G/4G IP failover & load balancing

VDSL2/ADSL2+ Analog (FXS/FXO), SIP eSBC Router/IAD



- 2-8 FXS or FXO (8 TDM calls)
- USB for 3G/4G IP failover & load balancing
- TDM failover to POTS

VDSL2/ADSL2+ T1/E1/PRI, SIP eSBC Router/IAD



- 1-4 T1/E1/PRI (up to 120 calls)
- TDM failover using any T1/E1 port

G.SHDSL Converged CPE/IAD Products

Patton's G.SHDSL Converged CPE products support 1–4 wire pairs with EFM or ATM wire bonding, and rates from 5.7 to 15.3 Mbps per wire-pair for speeds up to 60 Mbps per subscriber. Various hardware platforms support “All-IP” or a variety of analog (FXS), BRI, and T1/E1/PRI telephony and network interfaces. All models provide access network and service termination and demarcation, and include edge routing, voice, and data security as well as enterprise session border controller functions.

All units include:

- SIP eSBC licenses
- Multi-WAN IP failover and load balancing
- 1–4 pairs (wire bonding) up to 15.3 Mbps symmetrical, per pair
- CLI, Web, and TR-069 configuration and management

G.SHDSL ALL-IP SIP eSBC Router/IAD



SN5300

- 4 x 10/100 Ethernet (LAN & WAN), routing and switching
- Ships with 4 SIP sessions without transcoding
- USB for 3G/4G IP failover & load balancing

G.SHDSL ALL-IP SIP eSBC Router/IAD



SN5490

- 2 x 10/100/1000 Ethernet (LAN & WAN)
- Up to 128 SIP sessions without transcoding
- Up to 64 simultaneous transcoding channels

G.SHDSL BRI SIP eSBC Router/IAD



SN5530

- 2–8 BRI
- USB for 3G/4G failover & load balancing

G.SHDSL Analog (FXS/FXO), SIP eSBC Router/IAD



SN5540

- 2–8 FXS or FXO (8 TDM calls)
- USB for 3G/4G IP failover & load balancing
- TDM failover to POTS

G.SHDSL FXS+BRI, SIP eSBC Router/IAD



SN5550

- 2–4 BRI, 2–4 FXS, 2 FXS + 2 BRI, or 4 FXS + 4 BRI (8 TDM calls)
- USB for 3G/4G IP failover & load balancing

G.SHDSL T1/E1/PRI, SIP eSBC Router/IAD



SN5570

- 2 x T1/E1/PRI (30 calls)
- TDM failover using second T1/E1 port
- USB for 3G/4G IP failover & load balancing

G.SHDSL T1/E1/PRI, SIP eSBC Router/IAD



SN4990

- 1–4 T1/E1/PRI (up to 120 calls)
- TDM failover using any T1/E1 port

Ethernet-over-Fiber Converged CPE/IAD Products

Patton's fiber IAD products all support 1 SFP interface for WAN connections, and can receive a wide variety of SFP modules for Ethernet transport applications. The modules include a wide variety of single-mode and multi-mode fiber transmission technologies as well as “Smart SFPs” for MEF CE 2.0 compliant devices with OAM capabilities.

Support for the SFP interface enables demark applications as simple as fiber-to-copper media conversion to full NID functionality. Various hardware platforms support “All-IP” or a variety of analog (FXS), BRI, and T1/E1/PRI telephony and network interfaces. All models provide access network and

service termination and demarcation, and include edge routing, voice, and data security as well as enterprise session border controller functions.

All units include:

- 1 x Ethernet 10/100/1000 SFPs
- Full business class switching and routing capabilities
- SIP eSBC licenses
- Multi-WAN IP failover and load balancing
- Transcoded SIP to SIP calls
- CLI, Web, and TR-069 configuration and management

Ethernet-over-Fiber ALL-IP SIP eSBC Router/IAD



SN5490

- 2 x 10/100/1000 Ethernet (LAN & WAN)
- Up to 80 SIP sessions without transcoding
- Up to 64 simultaneous transcoding channels

Ethernet-over-Fiber BRI SIP eSBC Router/IAD



SN5530

- 2–8 BRI
- USB for 3G/4G IP failover & load balancing

Ethernet-over-Fiber Analog (FXS/FXO), SIP eSBC Router/IAD



SN5540

- 2–8 FXS or FXO (8 TDM calls)
- USB for 3G/4G IP failover & load balancing
- TDM failover to POTS

Ethernet-over-Fiber FXS+BRI, SIP eSBC Router/IAD



SN5550

- 2–4 BRI, 2–4 FXS, 2 FXS + 2 BRI or 4 FXS + 4 BRI (8 TDM calls)
- USB for 3G/4G IP failover & load balancing

Ethernet-over-Fiber T1/E1/PRI, SIP eSBC Router/IAD



SN5570

- 2 x T1/E1/PRI (30 calls)
- TDM failover using second T1/E1 port
- USB for 3G/4G IP failover & load balancing

Ethernet-over-Fiber T1/E1/PRI, SIP eSBC Router/IAD



SN4990

- 1–4 T1/E1/PRI (up to 120 calls)
- TDM failover using any T1/E1 port

Ethernet-over-Fiber SFP Module



SFP1G10

- 1 Gbps SFP optical transceiver, single-mode/10 km, 1310 nm

Ethernet-over-Fiber SFP Module



SFP1G20

- 1 Gbps SFP optical transceiver, single-mode/20 km, 1310 nm

Ethernet-over-Fiber SFP Module



SFP1G20B3

- 1 Gbps SFP optical transceiver, single-mode BIDI/20 km, TX1310 nm, RX1550 nm

Ethernet-over-Fiber SFP Module



SFP1G20B5

- 1 Gbps SFP optical transceiver, single-mode BIDI/20 km, TX1550 nm, RX1310 nm

For other SFP options, please contact sales@patton.com

VDSL2/ADSL2+ Modem/Bridge/Router Products

Patton's VDSL2 Modem/Bridge/Routers terminate high speed asymmetric ADSL2/VDSL2 services. These products are used in either "All-IP" (no analog or TDM interfaces) applications or in instances where the 2-box deployment, makes more sense. You can find more details on the 1-box-vs-2-box use case on page 22. Our ALL-IP VDSL2 CPEs portfolio fit into three primary categories: unmanaged bridges, residential class routers, and business class routers supporting dynamic routing, VPN, failover and load balancing.

VDSL2 100-Mbps Bridge



1069

- VDSL2
- 4 x 10/100 bridge
- Internal POTS/ISDN splitter
- Managed DIP switch

VDSL2/ADSL2+ Router



OS2201

- Annex A/L/M or B/J
- 1 x 10/100 router
- Managed-CLI, Web, TR-069

VDSL2/ADSL2+ Router



SN5501

- 2 x 10/100/1000 router
- USB for 3G/4G IP failover & load balancing
- Managed-CLI, Web, TR-069

VDSL2/ADSL2+ Router



SN5490

- 2 x 10/100/1000 router
- Managed-CLI, Web, TR-069

G.SHDSL Modem/Bridge/Router Products

Patton's G.SHDSL Modem/Bridge/Routers are for the termination of long range, symmetric G.SHDSL legacy (ATM/TDM/FR) or Ethernet First Mile (EFM) services. G.SHDSL is a very mature technology resulting in a very broad product line with several customer facing connectivity options including Ethernet, Frame Relay, ATM, TDM and sync serial. G.SHDSL modems are often used in point-to-point applications for the extension of E1/T1 and Ethernet circuits. Because of G.SHDSL's long history and wide range of standards and implementation, more care must be used when determining interoperability between a G.SHDSL CPE and G.SHDSL DSLAM.

G.SHDSL.bis TDM Modem



3088A

- 1 pair—5.7 Mbps symmetrical
- Choice: E1/T1, V.35, or X.21
- Managed-DIP switch, CLI

G.SHDSL FR, HDLC, ATM Router



3201/3204

- 1 pair—2.3 or 4.6 Mbps symmetrical
- 1 x 10/100 bridge
- Managed-DIP switch, CLI, Web

G.SHDSL.bis EFM/ATM Bridge



OS2300

- 1–2 pair (supports wire bonding) 15.3 Mbps symmetrical per pair
- 4 x 10/100 bridge
- Managed-CLI, Web, TR-069

G.SHDSL.bis EFM/ATM Router



OS3300

- 1–4 pair (supports wire bonding) 15.3 Mbps symmetrical per pair
- Optional (3G/4G failover)
- 4 x 10/100 router
- Managed-CLI, Web, TR-069

G.SHDSL.bis EFM/ATM Router



SN5501

- 1–4 pair (supports wire bonding) 15.3 Mbps symmetrical per pair
- 2 x 10/100/1000 router
- Managed-CLI, Web, TR-069

G.SHDSL.bis EFM/ATM Router



SN5490

- 1–4 pair (supports wire bonding) 15.3 Mbps symmetrical per pair
- 2 x 10/100/1000 router
- Managed-CLI, Web, TR-069

SmartNode CPE/IAD Unique Values

Converged Voice & Data Security

Unified Communications (UC) involves delivering voice, video and data over a single converged network. In order to deliver these converged services efficiently, SmartNodes have been designed to support all the industry-standard security features from both the Voice and Data perspective. This includes several propriety innovations and unique implementations unique to hosted telephony.

SmartNodes support configurable Public Key Infrastructure (PKI) and certificate authority. transport layer security (TLS) with symmetric cryptography strengthens and provides authentication protection for UDP and TCP transport and encrypted voice. The Patton Cloud automated certificate management services enhancing security regimes and making security management easy for Service Providers. Secure real-time protocol (SRTP) encryption protects the digitized voice within the RTP data unit. Of course, features such as SSH, HTTPS, NAT, DMZ (port forwarding), MAC and port filtering, ACL (stateful firewall), IPsec and OpenVPN are all standard. With the industry's richest suite of security features for voice and data, SmartNode IADs protect your ALL-IP communication system from intrusion, eavesdropping, tampering and/or traffic capture.

Assured Quality of Service

Assuring that VoIP call quality is maintained is mission-critical for the enterprise customers served by converged service and OTT offerings. Patton SmartNodes are designed as intelligent edge and service demarcation devices to guarantee this quality, even if the Service Provider does not control the Access Network. SmartNodes support a host of native QoS feature sets including TOS, DiffServ labeling, Active QoS with traffic scheduling and classification, weighted fair queuing & shaping of traffic classes with configurable burst tolerance. And when data floods the downstream link, DownStreamQoS™ can throttle incoming data to ensure time-sensitive voice traffic gets through to you promptly. Patton SmartWare for SmartNode now includes both DownStreamQoS and upstream QoS to deliver consistently clear voice in both directions. Patton's PacketSmart Service leverage deep packet inspection on-premise with Patton-Cloud services to give Service Providers full visibility into network end points. Measuring, analyzing and reporting, in real time, quality impacting events such as packet loss, latency, jitter and MOS score, SmartNodes assure QoS and enable providers to deliver superior quality of experience to subscribers.

Any-WAN Access Network Services

SmartNode IADs in this guide can perform access network terminations, service termination, or both. Equipped with a wide

variety of WAN access options including ADSL2+, VDSL2 vectoring, 2/4/8-wire bonded G. SHDSL, fiber SFP and 3G/4G/LTE, the SmartNode can replace various access network termination devices for access network providers and provide a platform for converged service delivery. With up to 4 WAN interfaces available, the SmartNode enables providers to deliver redundant, load balanced wired or wireless IP broadband links for ALL-IP services.

Multi-WAN (TDM & IP) Survivability

Using our automated onboard survivability features, end-point registrations are monitored, enabling instantaneous failover to redundant TDM or Multi-WAN broadband links, without the need for dual-registration or any changes to the network, on-premise, hosted service or end point device configurations. Re-direction, license services, quality monitoring and link monitoring are also available from the Patton Cloud for fully managed survivability.

Purpose-Built Hardware; Modular Software

SmartNodes are designed with carriers and services provider services and migration strategies in clear view. A host of hardware options deliver the most cost effective CPE solutions enabling service providers to exactly satisfy the current and future needs of SME customers and enterprise branch office needs without over spending on CPE capabilities and eliminating the need to modify, change or update hardware on subscriber premises. Patton Cloud-based license services allow for easy activation of feature and function licenses that can be "floated" across a service provider's installed base. Patton Cloud connectivity enables automated provisioning, re-provisioning or cloud-powered services without the need to replace the CPE.

Trusted Partner

SmartNodes are time-tested products in the market for more than 20 years, by a company with over 30 years of pedigree in data communications, networking, and telecom. The products are made in the USA and have been deployed in the millions by service providers and large enterprise customers in 150+ countries. Thousands of Certified SmartNode engineers have been trained and are supported by Patton's 7 technical assistance centers and 14 offices around the world.

Here at Patton, our engineering team is focused on protecting your UC network, traffic, and users.

IAD Product Tables

VDSL/ADSL Devices

Physical							IP/Ethernet								Coordinates										
WAN Access	Annex Type	Ethernet	Voice Ports	USB Peripheral	Transport	Layer 2	IPv4/IPv6	OA&M	Max SIP Sessions	Routing	Security	Survivability	VPN	Model	Page										
VDSL2	A, B	4x 10/100			N/A	Transparent Bridging	N/A	DIP Switch		N/A	N/A	N/A	N/A	1069	46										
ADSL2+ VDSL2	A, L, M & B, J	1x 10/100			PPPoAAL5, PPPoA, PPPoE, IPoATM, PTM	Transparent Bridging, DHCP Server/Client/Relay	IPv4/IPv6	GUI, TFTP, Telnet, SNTP, SNMP, TR- 069	N/A	Static, RIPv1/v2, IGMPv1/v2, Dynamic DNS, DNS Relay, UPnP	MAC & Port Filtering, DoS, DMZ, ACL	N/A	N/A	OpenVPN, IPsec	OS2201	45									
		2x 10/100/1000 (LAN or WAN)				Transparent Bridging, DHCP Server/Client	IPv4/IPv6 ready								GUI, TFTP, Telnet, SNTP, SNMP, TACACS+, TR-069	80	200	Static Routing, Class based routing, RIPv1/v2, IGMPv1/v2, Dynamic DNS, DNS Relay, UPnP, BGP, GRE	SSH, NAT, MAC & Port Filtering, DoS, DMZ, ACL, TLS, HTTPS, SIP Trust remote. Stateful Firewall	Wired Multi-WAN Failover	SN5490	35			
				✓																			Wired or Wireless Multi-WAN Failover	SN5500	34
			2-8 FXS	✓																			Wired or Wireless Multi-WAN Failover, TDM Failover (FXO)	SN5540	32
			2-4 BRI/ 2-4 FXS	✓																			Wired or Wireless Multi-WAN Failover, TDM Failover	SN5550	31
			2-8 BRI	✓																				SN5530	33
			1 PRI (2nd fallback)	✓																				SN5570	30
1 or 4 PRI (T1/E1)	✓				SN4990	38																			
							80		Static, RIPv1/v2, IGMPv1/v2, GRE, DNS Relay		Wired Multi-WAN Failover, TDM Failover														

G.SHDSL Devices

Physical								IP/Ethernet								Coordinates						
WAN Access	Annex Type	# of wire pairs	Mode	Serial Interface	Ethernet	Voice Ports	USB Peripheral	Transport	Layer 2	IPv4/IPv6	OA&M	Max SIP Sessions	Routing	Security	Survivability	VPN	Model	Page				
G.SHDSL	A, B	1	TDM	V.35, X.21, E1	1x 10/100			TDM	N/A	N/A	DIP Switch		N/A	N/A	N/A	N/A	3088A	43				
			ATM, HDLC, FR			PPPoE, PPPoA, IPoEoA, IPoA	Transparent Bridging, DHCP Server	IPv4	GUI, Telnet, SMTP, SNMP	N/A	RIPv1/v2, IMGPv1/v2, DNS Relay	DoS, ACL, NAT, Firewall	N/A	N/A	NO	3241	42					
	F, G	ATM, EFM	1-4			4x 10/100		Optional								PPPoA, PPPoE, PPPoAAL5, IPoATM, PTM	Transparent Bridging, DHCP Server/Client	IPv4/IPv6 ready	GUI, TFTP, Telnet, SNTP, SNMP, TACACS+, TR-069	Optional	200	Static Routing, Class based routing, RIPv1/v2, IGMPv1/v2, Dynamic DNS, DNS Relay, UPnP, BGP, GRE
						2x 10/100/1000			Wired Multi-WAN Failover.	SN5490	35											
						4x 10/100	✓				SN5300	36										
							✓				SN5500	34										
			1-2			2-8 BRI	✓				SN5530	33										
						2-8 FXS	✓				SN5540	32										
						2-4 BRI/ 2-4 FXS	✓				SN5550	34										
						1 PRI (2nd Fallback)	✓				SN5570	30										
			1 or 4 PRI (T1/E1)	✓									SN4990	38								

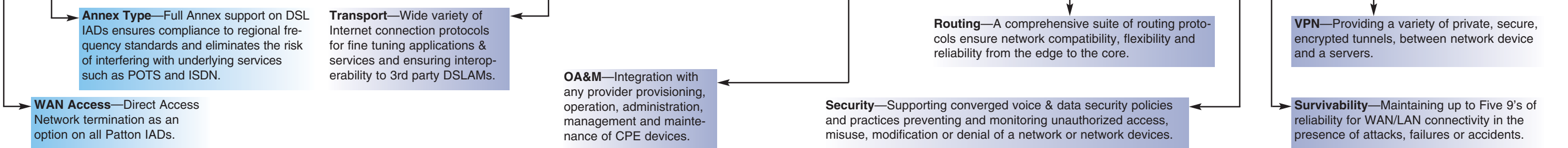

IAD Product Tables

Ethernet Devices

Physical				IP/Ethernet								Coordinates		
WAN Access	Ethernet	Voice Ports	USB Peripheral	Transport	Layer 2	IPv4/IPv6	OA&M	Max SIP	Routing	Security	Survivability	VPN	Model	Page
Ethernet WAN	2 x 10/100/1000			PPPoE	Transparent Bridging, DHCP Server/Client	IPv4/IPv6 ready	GUI, TFTP, Telnet, SNMP, TACACS+, TR-070	80	Static, RIPv1/v2, IGMPv1/v2, GRE, DNS Relay	SSH, NAT, MAC & Port Filtering, DoS, DMZ, ACL, TLS, HTTPS, SIP Trust remote. Statefull Firewall	Wired Multi-WAN Failover.	OpenVPN, IPSec	SN5490	35
	4 x 10/100		✓				GUI, TFTP, Telnet, SNMP, TACACS+, TR-071	60			Multi-WAN Wired/Wireless		SN5300	36
	2 x 10/100/1000		✓				GUI, TFTP, Telnet, SNMP, TACACS+, TR-072	200			Wired or Wireless Multi-WAN Failover. TDM Failover		SN5500	34
		2-8 BRI	✓				GUI, TFTP, Telnet, SNMP, TACACS+, TR-073				Wired or Wireless Multi-WAN Failover. TDM Failover		SN5530	33
		2-8 FXS	✓				GUI, TFTP, Telnet, SNMP, TACACS+, TR-074				Wired or Wireless Multi-WAN Failover. TDM Failover (FXO)		SN5540	32
		2-4 BRI /2-4 FXS	✓				GUI, TFTP, Telnet, SNMP, TACACS+, TR-075				Wired or Wireless Multi-WAN Failover. TDM Failover		SN5550	31
		1 PRI (2nd fallb)	✓				GUI, TFTP, Telnet, SNMP, TACACS+, TR-076				Wired or Wireless Multi-WAN Failover. TDM Failover		SN5570	30
	1 or 4 PRI (T1/E1)						GUI, TFTP, Telnet, SNMP, TACACS+, TR-069	80			Wired Multi-WAN Failover.		SN4990	38

Fiber Devices

Physical				IP/Ethernet								Coordinates		
WAN Access	Ethernet	Voice Ports	USB Peripheral	Transport	Layer 2	IPv4/IPv6	OA&M	Max SIP Sessions	Routing	Security	Survivability	VPN	Model	Page
Ethernet SFP	2 x 10/100/1000		✓	PPPoE	Transparent Bridging, DHCP Server/Client	IPv4/IPv6 ready	GUI, TFTP, Telnet, SNMP, TACACS+, TR-069	80	Static Routing, Class based routing, RIPv1/v2, IGMPv1/v2, Dynamic DNS, DNS Relay, UPnP, BGP, GRE	SSH, NAT, MAC & Port Filtering, DoS, DMZ, ACL, TLS, HTTPS, SIP Trust remote. Statefull Firewall	Wired Multi-WAN Failover.	OpenVPN, IPSec	SN5490	35
			✓					Wired or Wireless Multi-WAN Failover			SN5500		34	
		2-8 BRI	✓					Wired or Wireless Multi-WAN Failover, TDM Failover			SN5530		33	
		2-8 FXS	✓					Wired or Wireless Multi-WAN Failover, TDM Failover (FXO)			SN5540		32	
		0 or 4 PRI (T1/E1)	✓					Wired or Wireless Multi-WAN Failover, TDM Failover			SN5550		31	
		2 PRI (2nd fallback)	✓					Wired or Wireless Multi-WAN Failover, TDM Failover			SN5570		30	
1 to 4 PRI (T1/E1)			80	Static, RIPv1/v2, IGMPv1/v2, GRE, DNS Relay	Wired Multi-WAN Failover	SN4990	38							

Transport—Wide variety of Internet connection protocols for fine tuning applications & services and ensuring interoperability to 3rd party DSLAMs.

Annex Type—Full Annex support on DSL IADs ensures compliance to regional frequency standards and eliminates the risk of interfering with underlying services such as POTS and ISDN.

OA&M—Integration with any provider provisioning, operation, administration, management and maintenance of CPE devices.

Routing—A comprehensive suite of routing protocols ensure network compatibility, flexibility and reliability from the edge to the core.

Security—Supporting converged voice & data security policies and practices preventing and monitoring unauthorized access, misuse, modification or denial of a network or network devices.

VPN—Providing a variety of private, secure, encrypted tunnels, between network device and a servers.

Survivability—Maintaining up to Five 9's of reliability for WAN/LAN connectivity in the presence of attacks, failures or accidents.

VDSL2 Performance Innovations

VDSL2 Vectoring

Cable bundles typically consist of several densely packed cables. When signals are passed over these cables they will cause noise or interference to each other, this is known as crosstalk. Crosstalk is the primary reason lines in the field perform significantly lower than VDSL2's promise. VDSL2 vectoring removes crosstalk and interference allowing service providers to realize VDSL2's true performance.

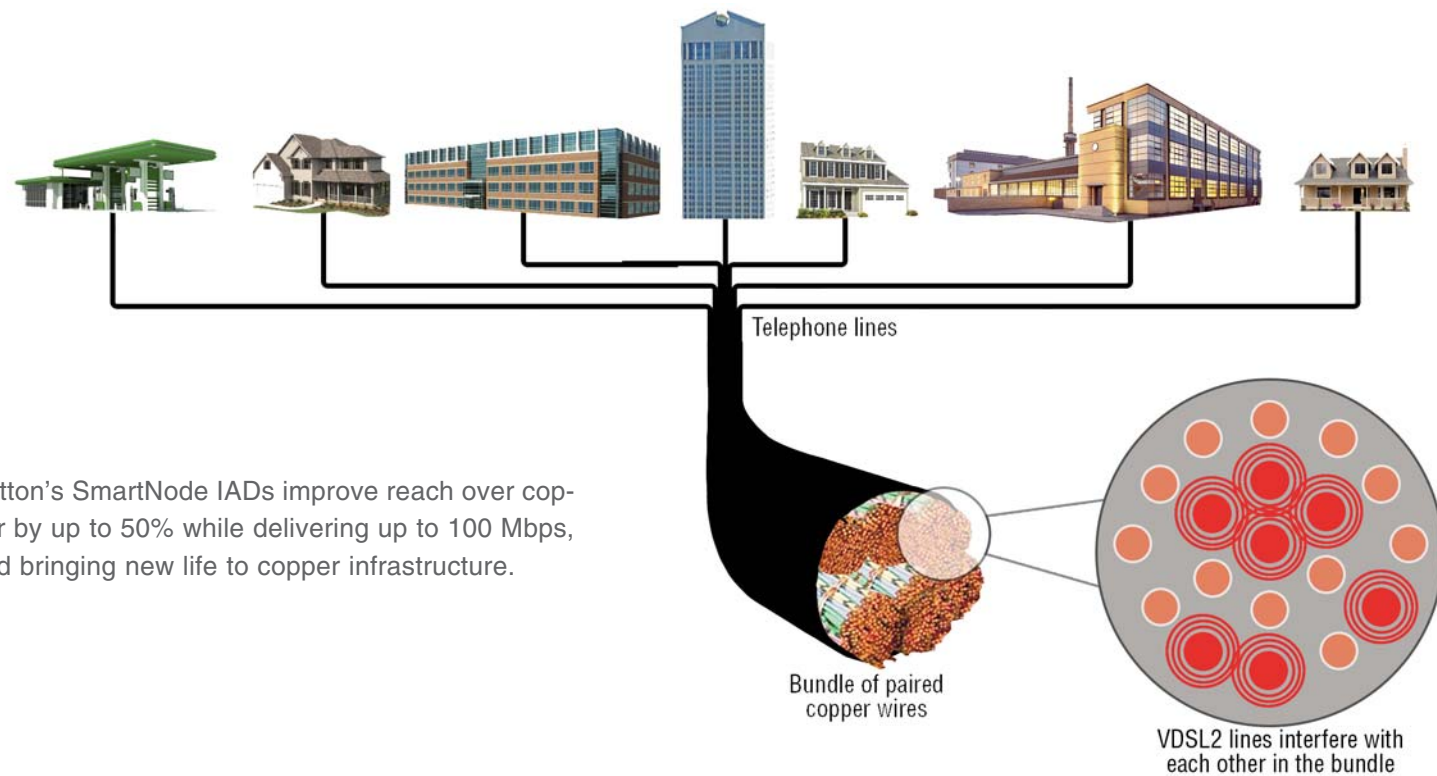

Patton's SmartNode IADs improve reach over copper by up to 50% while delivering up to 100 Mbps, and bringing new life to copper infrastructure.

How VDSL2 Vectoring Works

The crosstalk coupling into each VDSL2 line is measured and used to generate an anti-noise signal in the DLSAM to eliminate crosstalk on the line.

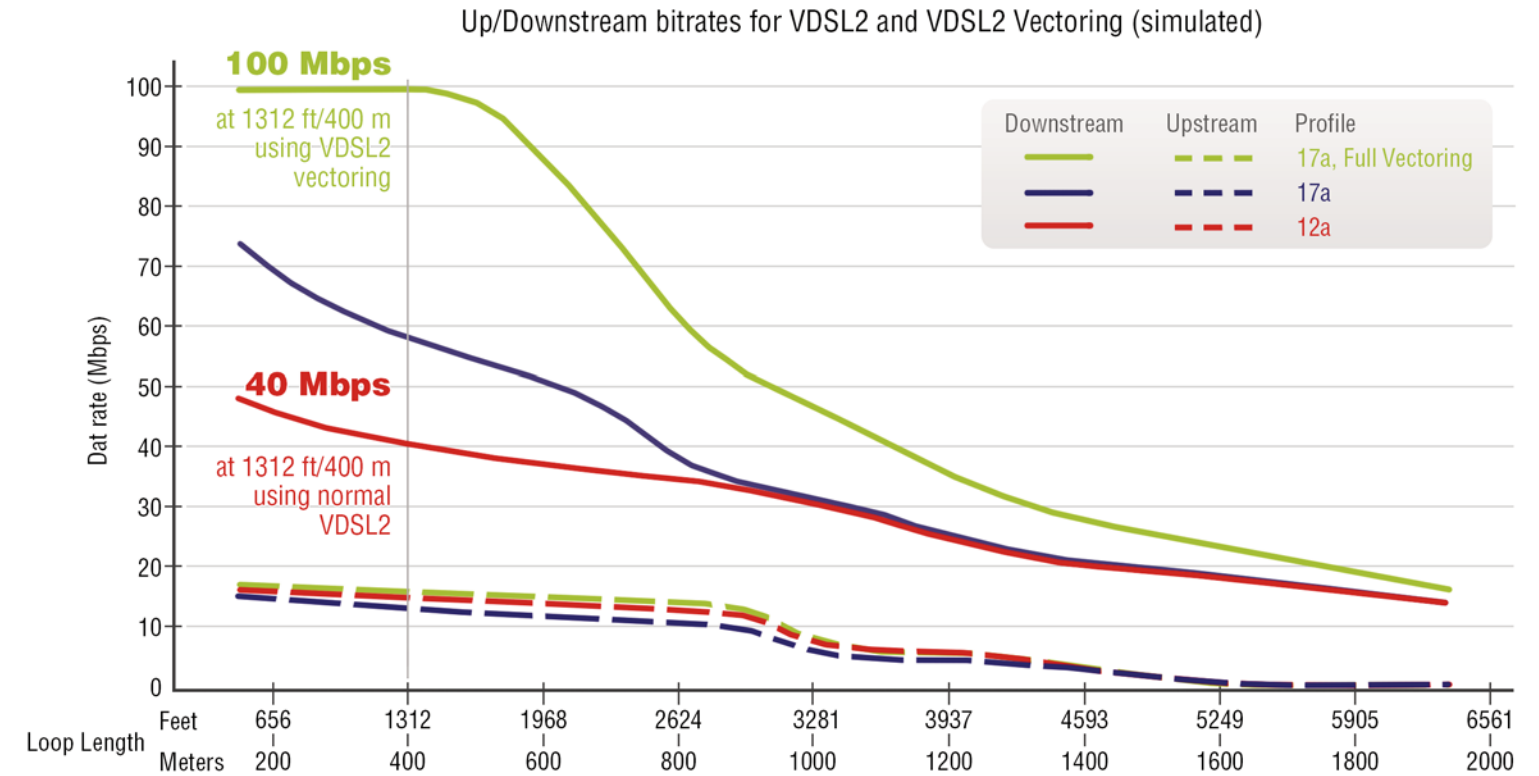
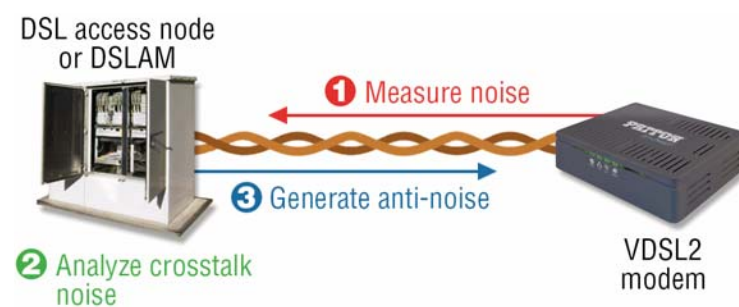

VDSL2 Profiles

VDSL2 supports 8 profiles with varying maximum downstream and upstream throughput as well as different bandwidth frequencies and transceiver power. Different profiles are optimal for different deployment scenarios. For example, profiles 8a–8b and 12a–12b are ideal for Fiber to the Node (FTTN) copper (DSL) to the premise. Profiles 17a for Fiber to the Cabinet (FTTCAB) and profile 30a for Fiber to the Building (FTTB). Profiles 8a–8b, 12a–12b and 17a include support for underlying services such as POTS or ISDN. Patton's VDSL2/ADSL2+ products also have the capability to fall back to ADSL2+ mode if no VDSL2 signal can be attained.

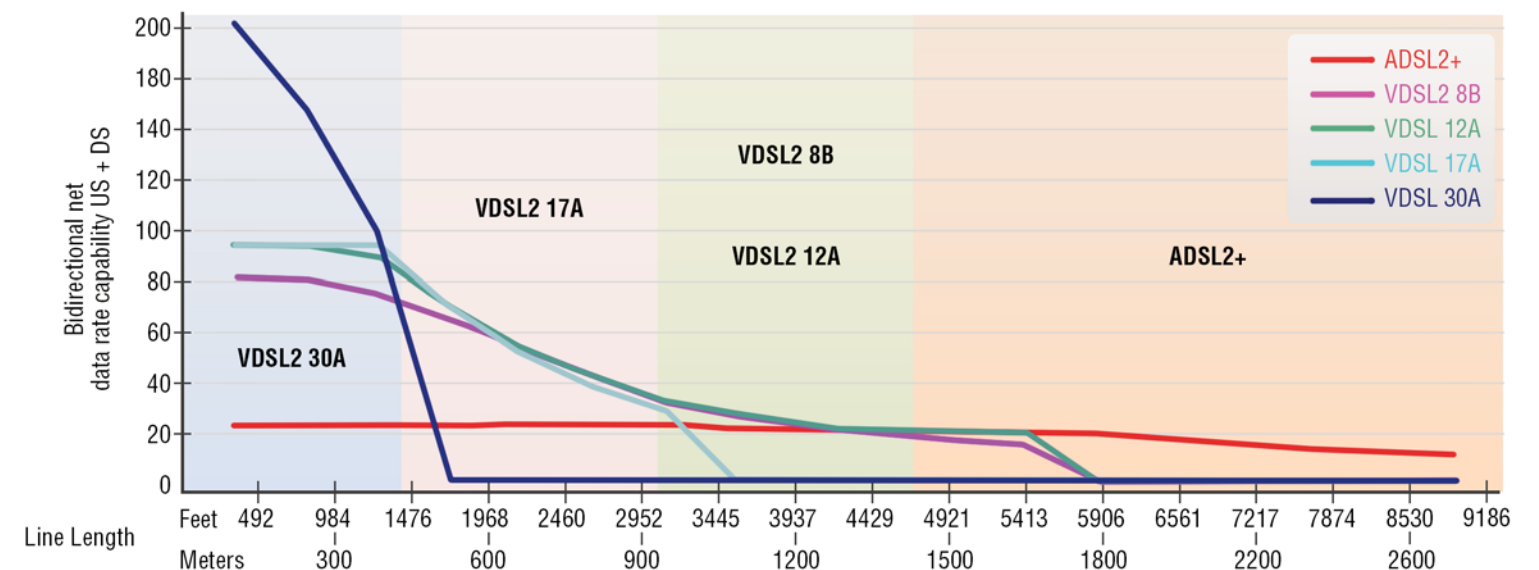

ADSL Performance Enhancements

Asymmetric digital subscriber line (ADSL) bandwidth and bit rate are asymmetric, meaning greater toward the customer premises (downstream) than the reverse (upstream). The figure below shows the rate and reach downstream performance of the primary versions of ADSL.

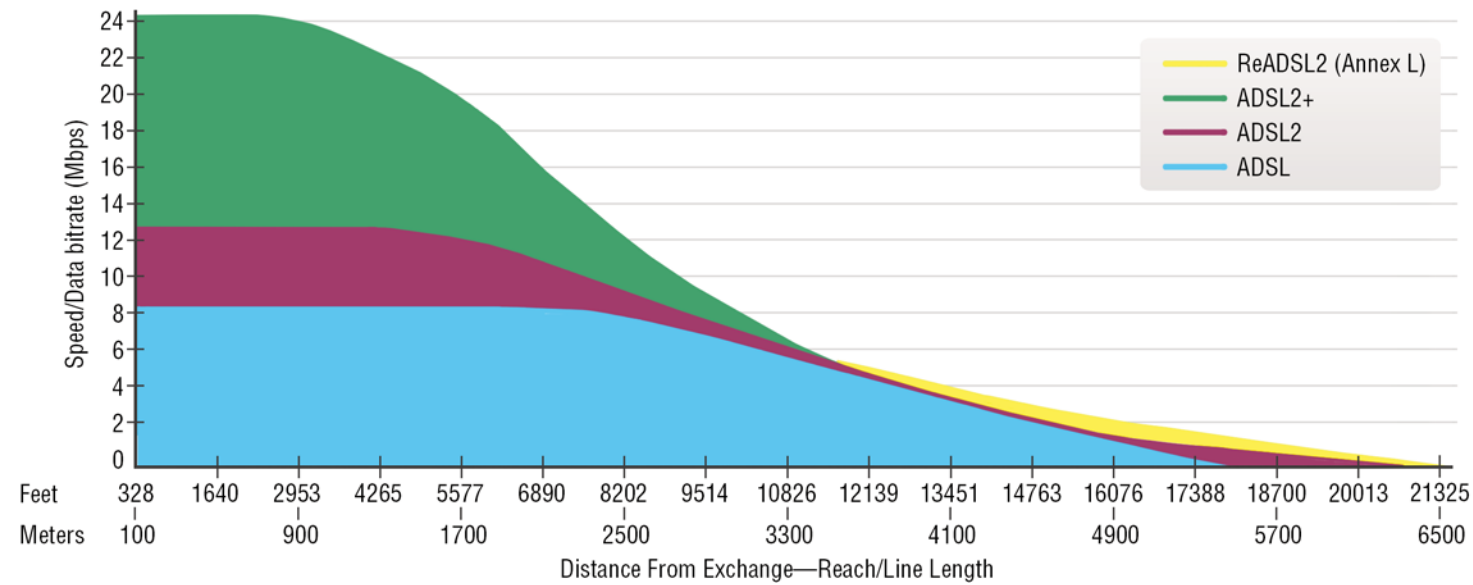

xDSL Performance Comparisons

Symmetric High-speed digital subscriber line (SHDSL) bandwidth and bit rate are symmetric, meaning equal toward the customer premises (downstream) than the reverse (upstream). The figure below represents estimated rate and reach potential for the various different flavors of xDSL. ADSL and VDSL rates reflect downstream only. SHDSL is symmetrical so any rates shown on this table reflect both the downstream and upstream rates.

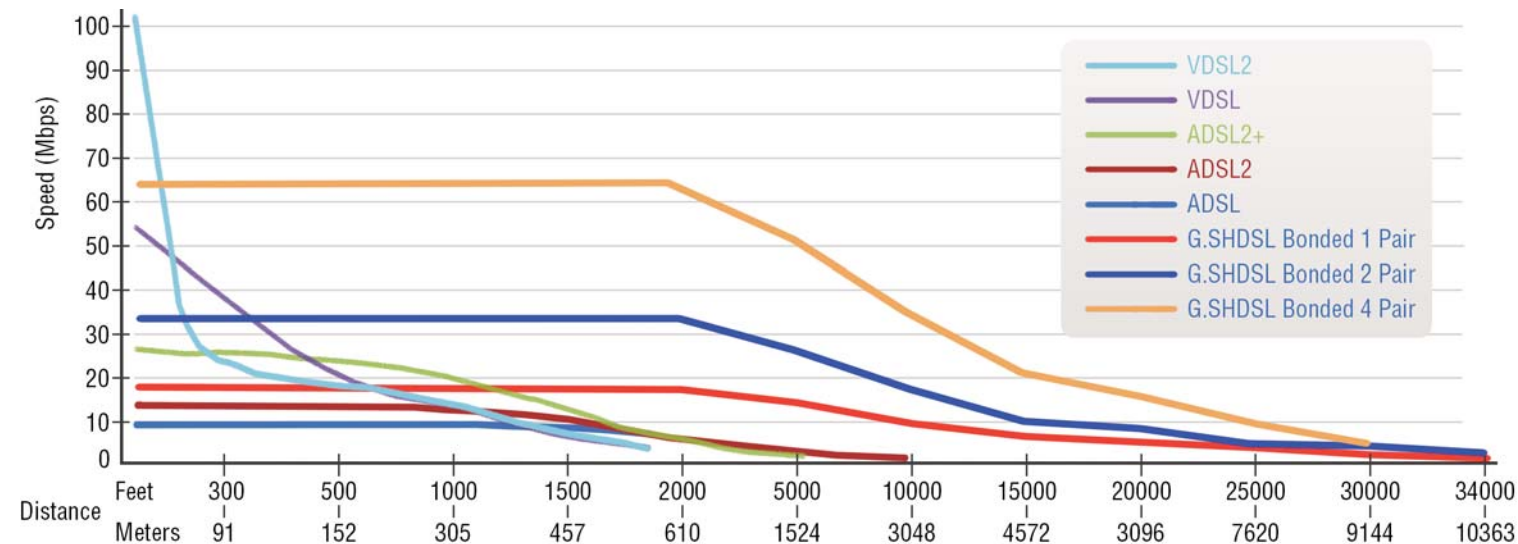

G.SHDSL Performance Innovations

G.SHDSL.bis is a technology allowing for high speed symmetric transmission of data over copper lines. SHDSL's symmetric nature makes it ideally suited for small to medium enterprises UC applications while its reliability and noise immunity makes it the clear choice for industrial or other mission critical infrastructure applications or environments.

SHDSL.bis supports data rates of up to 5.7 Mbps per copper wire pair. Standard port-bonding techniques enable this bandwidth to be shared across as many as 4 pairs and aggregated together for 22 Mbps downstream and upstream. Even higher data rates can be achieved using different TC-PAM modulation schemes. Patton's IADs support TC-PAM 64 and TC-PAM 128 high speed modulation schemes. These schemes achieve up to 3 times the bandwidth as standard SHDSL.bis by using a broader spectrum and putting more power on the line. These two factors will result in crosstalk to adjacent copper pairs, making these modes best suited for private enterprise, campus or mobile backhaul applications.

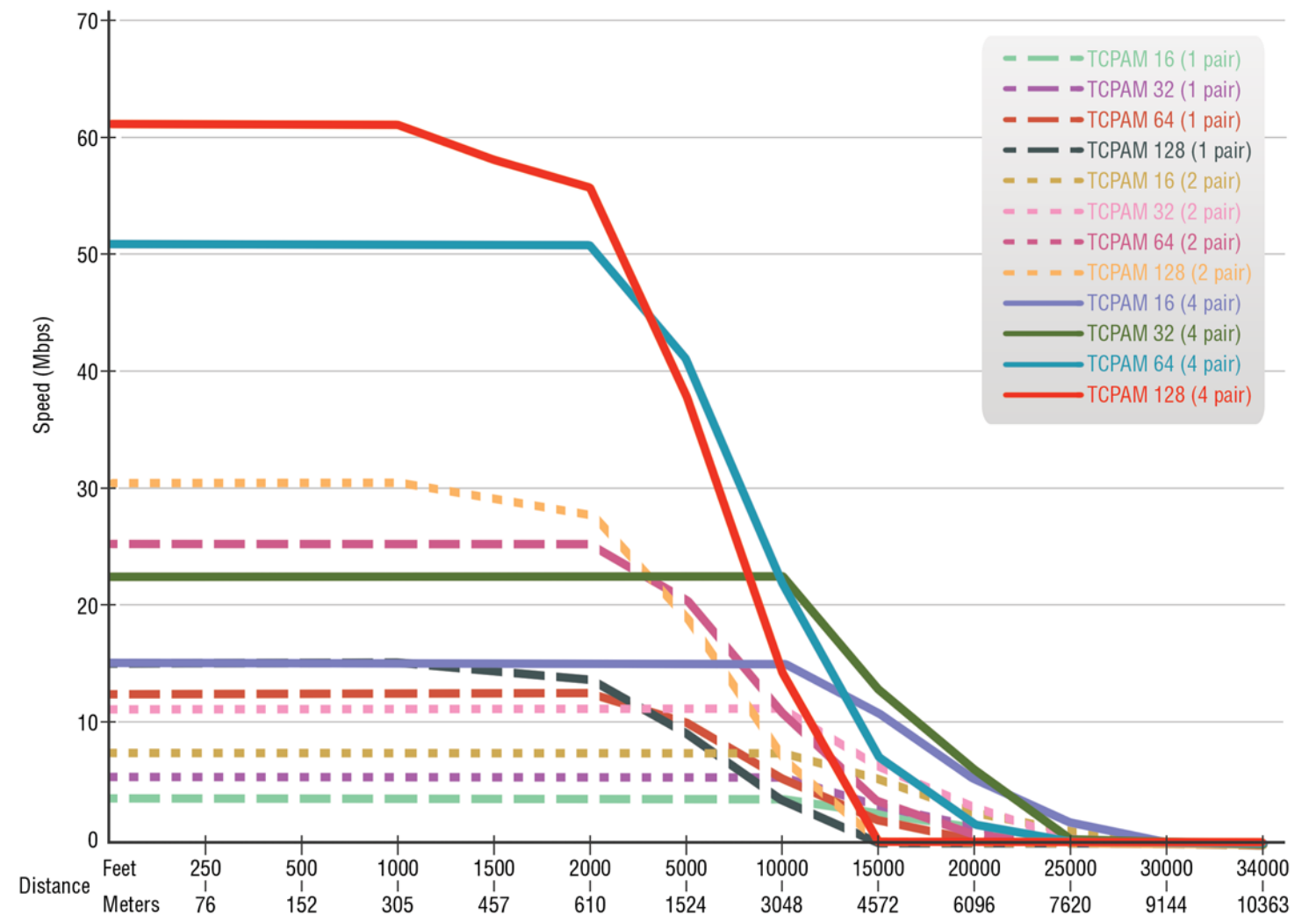

Solution Considerations

SIP Trunking

Patton's SmartNode product, over the last 20 years, has achieved universal interoperability with the industries winning Softswitch and IMS platforms and has been functionally integrated with all major and minor brand of on-premise PBX and UC solutions. SmartNodes offer superior SIP normalization services making it the best service delivery and service demarcation device for any SIP Trunking services. Hearty voice features a wide range of supported Codec, a full Call Routing engine, Enterprise dial plan support and fully integrated eSBC functionality makes the SmartNode an unrivaled value to the Service Provider.

Delivering a wide variety of TDM interfaces, SmartNodes enable Carriers to easily transition TDM trunk subscribers to SIP's trunks, while delivering a no-touch, future proof path to All-IP. Further migrating customers from SIP Trunks to Cloud based Telephony, Cloud Data services and SDN, NFV based services means that a small investment in a Patton CPE goes a very long way.

Hosted Telephony

The SmartNode enables seamless and hassle free migration from on-premise TDM or IP PBX systems and either TDM or SIP trunks to Hosted VoIP. Legacy stations can connect and SIP phones alike can register with hosted PBX services with Patton TDM enabled eSBCs. SIP normalization, QoS, network monitoring and enhanced voice & data security features make the SmartNode a perfect Service Demarcation device for OTT services. Using our automated survivability features, end-point registrations with hosted services are monitored, enabling instantaneous failover to redundant TDM or Multi-WAN broadband links, without the need for dual-registration or any changes to the hosted service or end point device configurations. Re-direction, license services, quality monitoring and link monitoring are also available from the Patton Cloud.

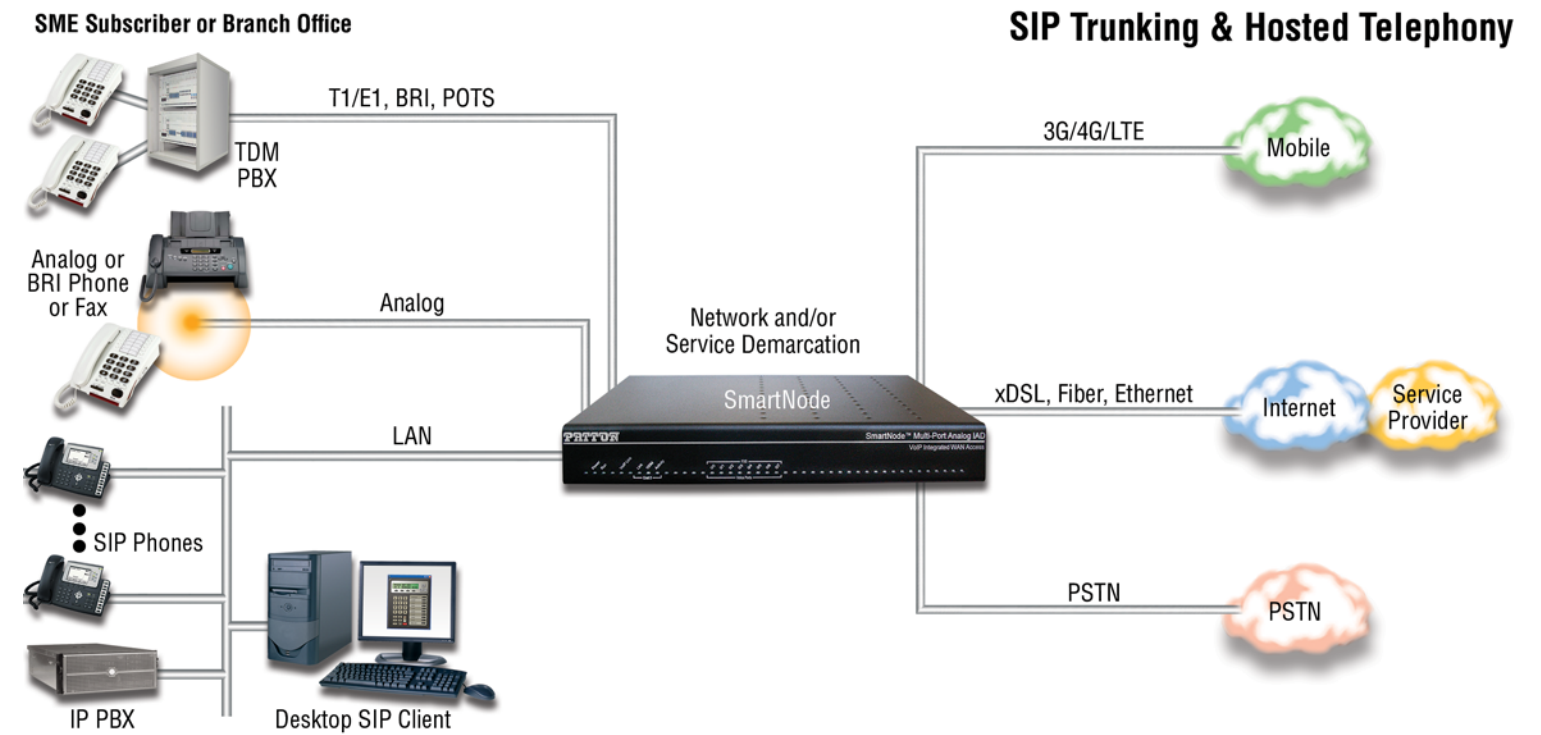

Converged Voice & Data Managed Services

Providing enterprise class edge routing, switching, QoS in a single CPE device, the SmartNode is perfectly suited for MSOs adding Managed Voice services to Data Service offerings. If any MSO is delivering third party SIP Trunks or Hosted Telephony in addition to existing data services, the Patton SmartNode gives the MSO the ability to fully monitor and control both the enterprise network and the voice service demarcation. Providing a wide array of Management, Monitoring and Troubleshooting tools the SmartNode ensures MSO's can deliver high quality converged services.

Branch Office Managed Voice & Data

Large Enterprises have rapidly deployed ALL-IP voice and data services in their large HQ facilities. They have struggled to find solutions for Branch Offices with a diverse set of broadband and telephony solutions on-premise. The diversity and interoperability of the SmartNode ensures a low-cost one-box migration solution, regardless of end-points or strategy for migration of the branch offices. Supporting secure tunnels, VPN connections, local converged voice & data security (Encryption, TLS, local Firewall etc.) and VLANs the SmartNode ensures secure connections between the HQ and its branch offices. With local voice services and call routing capabilities the SmartNode can integrate with any enterprise dialing plan, even if diverse multi-vendor and multi-generation voice systems.

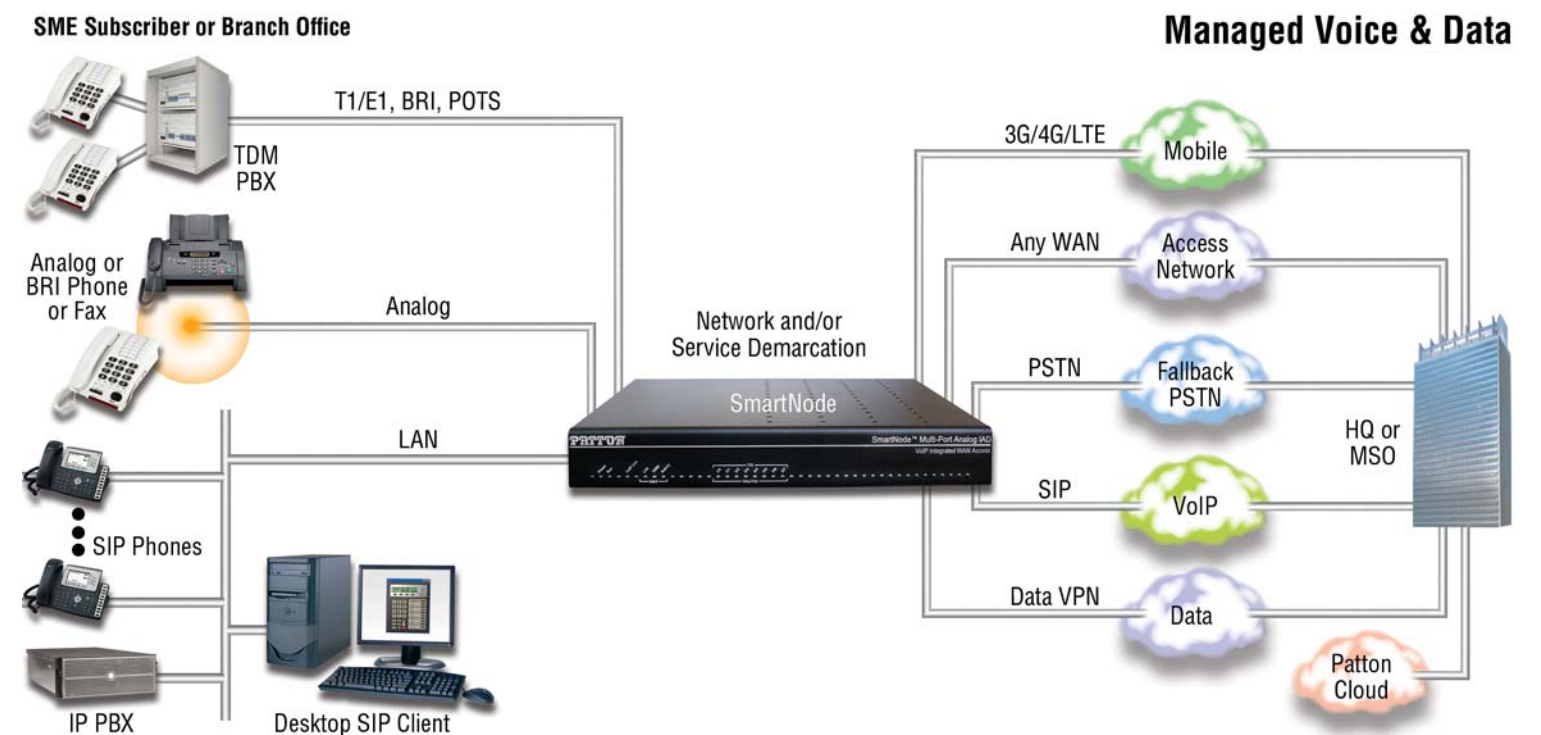

Solution Considerations

Multi-Box or One-Box CPE?

The world of business communications has been evolving: migrating from TDM to IP and on-premises solution to the cloud. Mobile communications is exploding. These trends create the need for CPE devices that enable and empower this transformation. The market requires CPE that incorporate network demarcation, service termination, legacy device integration, multi-WAN, cloud-connectors, eSBC functions and virtualization (SDN/NFV), as illustrated below.

The Patton SmartNode portfolio addresses all the challenges involved in migration from TDM to All-IP—regardless of how incrementally or rapidly it is performed.

Whether you need a simple VoIP gateway to connect TDM-based equipment to an IP network, or a fully-managed and monitored CPE that deliver Internet-access, voice and data services and everything in between, Patton has you covered.

Patton’s SmartNode units are available to support any level of integration or dis-integration at the customer premise. SmartNode offers cost-effective and efficient solutions for service providers that save money, reduce hardware requirements, and simplify network architecture at the customer premise. The graphic below shows a schema of the options. The “1-box solution” integrates as many functions as possible into a single device, which we call an Integrated Access Device (IAD).

As the diagram below shows, L1/2 transmission technology, L3/4 routing and security features—as well as higher layer service functions such as media gateways and signaling—are all built into the same box.

“Multi-box-solutions” divide different OSI Layer functions among separate devices. The CPE setup may easily include 4 or 5 dedicated devices for transmission, routing, firewall, bandwidth-optimization, media gateway functions and signaling. Patton’s SmartNode products deliver all of these functions in a single low-cost platform. Any or all functions can be turned on or off through cloud-based licensing services.

Highly-integrated CPE come with advantages and disadvantages. Same with multi-box CPE solutions. These pros and cons can vary based on both the service provider type (access, service OTT) and based on the target subscriber market (residential, SME, enterprise).

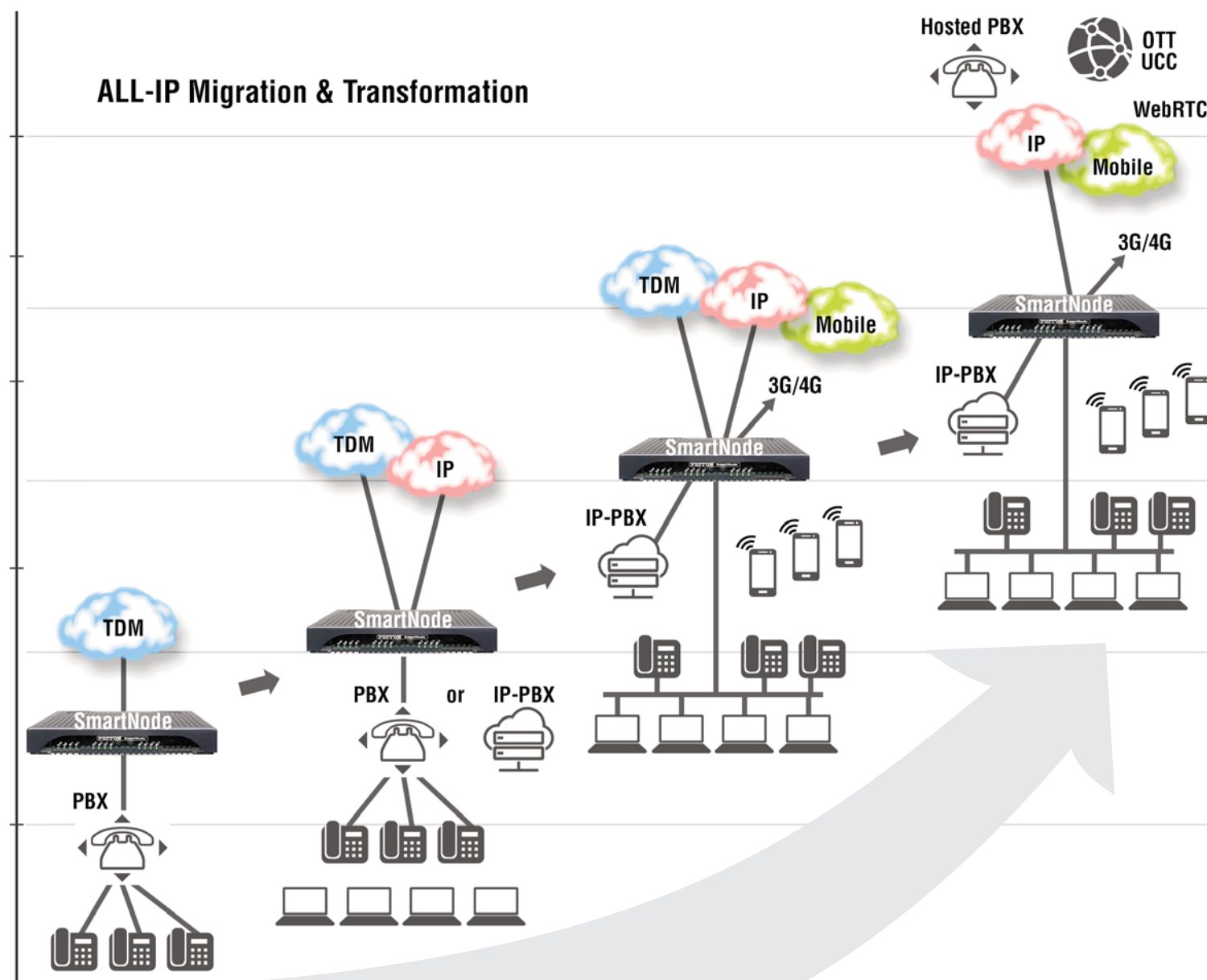

OSI Functions	Modem, Router & Gateway	Integrated Access Device (IAD)	Modem/Router & Media Gateway	Modem & Router/Gateway
WAN	Cloud	Cloud	Cloud	Cloud
Modem Layers 1 & 2	Modem	IAD	Modem/Router	Modem
Router Layer 3	Router		Router/Gateway/Appliance	
Services Layers 4-7	Gateway/Appliance	Gateway/Appliance	Gateway/Appliance	Gateway/Appliance
LAN				

Solution Considerations

Access Termination, Service Termination, Edge Router, eSBC, Security Appliance			
Provider Type/Market Focus	Arguments for a More Integrated CPE (1-box solution)	Arguments for a Less Integrated CPE (multi-box solution)	Other considerations
Access Network Provider	Bind customers by providing full-service range with 1 box. Standardize on one access technology (DSL, Fiber, Cable)	Standardize on one transmission box and differentiate services with multiple service boxes.	
Business Service Provider	Simpler management and better security with minimal number of boxes.	Focus on services, evolve and scale independent of underlying access and transmission.	Total numbers of SKUs to consider for logistics and network management depends on the range of access networks and subscriber segments.
OTT Service Provider		Standardize on a service-box with Ethernet uplink independent on the underlying access technology. Manage service end-to-end over any access network.	Look for monitoring capabilities to assess the subscriber SLA as well as the quality of the access network.
Residential	Simpler, cleaner installation (less boxes, cables and power plugs) Simpler setup and management Better security (no Layer 2 access) Fewer boxes, simpler logistics 1 size fits all.		Highly integrated hardware and automated provisioning and management.
SME		Fewer number of boxes to manage a range of subscriber interfaces over a range of access networks.	
Large Enterprise		Best in class box for every function (routing, security, voice, ...). Custom designed CPE architecture to match customer feature and performance requirements.	



Get the white paper: "CPE Architecture: When Does All-IP Equal All-in-One?". It's free!

As the telecom world goes All-IP, aspects such as service quality, security, and reliability are under heavy scrutiny. Equipment vendors, service providers and consultants are promoting solutions to these ever-evolving challenges. This document explores from the perspective of service providers making decisions about functional network architectures on the customer premises.

www.patton.com/CPEarch

CPE-to-CPE Ethernet Extenders

Patton Electronics manufactures a wide range of private line communication devices called CopperLink™ Ethernet Extenders. CopperLink Ethernet Extenders are preconfigured to work point-to-point (CPE to CPE) and optimized for use over private copper twisted-pair.



PoE/PoE+ over Copper or Coax Long Reach Power over Ethernet Extender



CL1101

- Maximum Rate 100 Mbps
- Maximum Reach 3,000 ft (1 km)
- PoE+ Extension
- 1 port Ethernet (PoE+)
- Unmanaged

Ethernet over Copper Long Range Ethernet Extender with Bonding



CL2300

- Max Line Rate 60 Mbps
- Max Reach 33,000 ft (10 km)
- Supports Pair Bonding (up to 4)
- 4 port Ethernet
- Managed

Ethernet over Copper or Coax High Speed Ethernet Extender



CL1200

- Maximum Rate 100 Mbps (Downstream)
- Maximum Reach 10,000 feet (3 km)
- 1-4 port Ethernet
- POTS Splitter (Optional)
- Unmanaged

Ethernet over Copper Long Range Ethernet Extender



CL1300

- Max Line Rate 30 Mbps
- Max Reach 33,000 ft (10 km)
- Supports Pair Bonding (up to 2)
- 4 port Ethernet
- Managed

Get the full CopperLink Ethernet Extenders Product Guide. It's free!

Patton's CopperLink Ethernet Extenders appear in a wide variety of environments, including business offices, mining tunnels, oil rigs and drills, manufacturing facilities, vehicular traffic management, security monitoring, maritime vessels, sporting arenas, nuclear power facilities, agriculture, and more!



www.patton.com/EEPG

Solution Considerations

Ethernet Aggregation

Not all applications are ideally suited for point-to-point or CPE-to-CPE connectivity. Campuses, hospitality, military bases and other similar environments with the need to reach several Ethernet end-points can be better served with Patton's DSLAMs. A DSLAM provides Ethernet extension over twisted pair for up to 24 CPEs and then aggregates the traffic from those 24 individual modem connections into single or dual high capacity Gigabit Ethernet port(s). Our DSLAMs include advanced traffic management features for the optimization of voice, video, and data traffic as well simple to use status report and monitoring tools of all your connected CPE via a single Web GUI. Patton's DSLAMs can connect to third-party standards-based CPEs, integrated access concentrators (IAC), Patton IADs, DSL CPEs, and our CopperLink Ethernet Extenders.

Ethernet-over-Copper Aggregation VDSL2



FF3210P

- Max Line Rate 100 Mbps
- Max Reach 10,000 ft (3 km)
- Supports Pair Bonding (up to 4)
- Compatible with third-party VDSL2 CPE
- Compatible Patton devices:
 - CPE: 1069, CL1200, OS2201
 - IAD: SN4990, SN5490, SN5530, SN5540, SN5500, SN5570

Ethernet-over-Copper Aggregation G.SHDSL



FF3310P

- Max Line Rate 100 Mbps
- Max Reach 10,000 ft (3 km)
- Supports Pair Bonding (up to 4)
- Compatible with third-party VDSL2 CPE
- Compatible Patton devices:
 - CPE: 1069, CL1200, OS2201
 - IAD: SN4990, SN5490, SN5530, SN5540, SN5500, SN5570

Extender & IAD Environmental Options

Our DSL CPE and CopperLink Ethernet Extenders are available in a wide variety of form factors and cover nearly all the legacy and common topologies practiced today.

Rugged

MAXIMUM +85°C
MINIMUM -40°C
CORROSION PROTECTION

Outdoor

CORROSION PROTECTION
DUST/WATER PROTECTION
MAXIMUM +85°C
MINIMUM -40°C

Indoor

OEM

Ethernet Extension Topologies & Use Cases

Patton Electronics manufactures a wide range of private line communication devices called CopperLink™ Ethernet Extenders. CopperLink Ethernet Extenders are preconfigured to work point-to-point (CPE to CPE) and optimized for use over private copper twisted-pair.

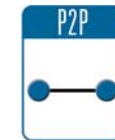

Point-to-Point

The most common application for Ethernet extenders is PTP connectivity. This application requires the use of a local and remote Ethernet extender.

Applications includes remote office backhaul or Ethernet extension to remote devices such as wireless access points, IP phone/intercoms, IP cameras, etc.

- Remote Office(s) Backhaul
- IP Camera Extension
- VoIP Extension
- WAP Extension

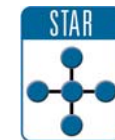
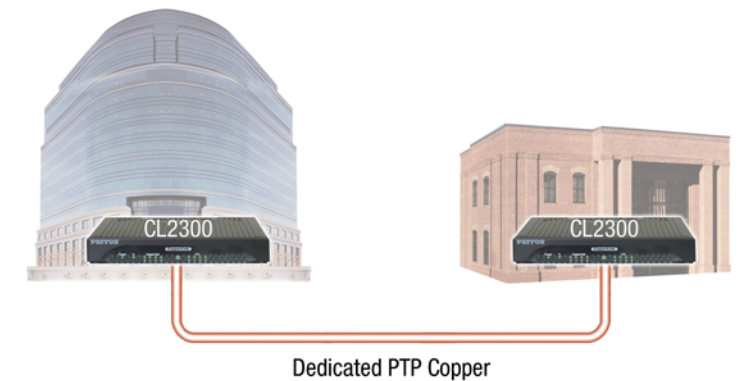

Star

The star topology consists of a centrally located DSLAM or long range Ethernet (LRE) switch that is of connecting to 24 individual remote Ethernet Extenders, and aggregates all the traffic from its LRE ports to a single or multiple Gigabit Ethernet ports. Common use cases for the star topology include various Multi-Dwelling

(MxU) applications, campus connectivity, and broadband services for small service areas.

- Hospitality
- Multi-Dwelling (MDU/MTU/MxU)
- Small service area broadband
- Camp/Campus/Base

Hospitality (MDU/MTU/MxU)

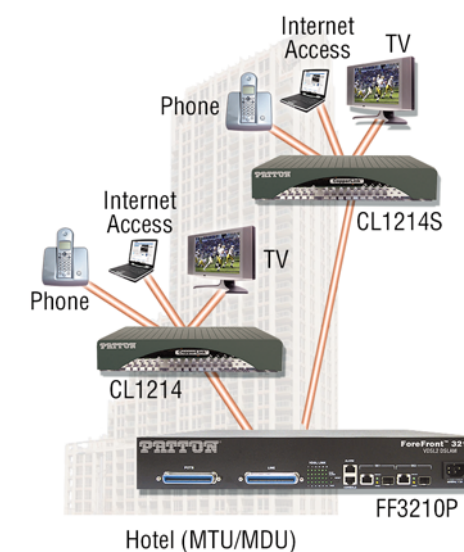

Broadband Small Service Area

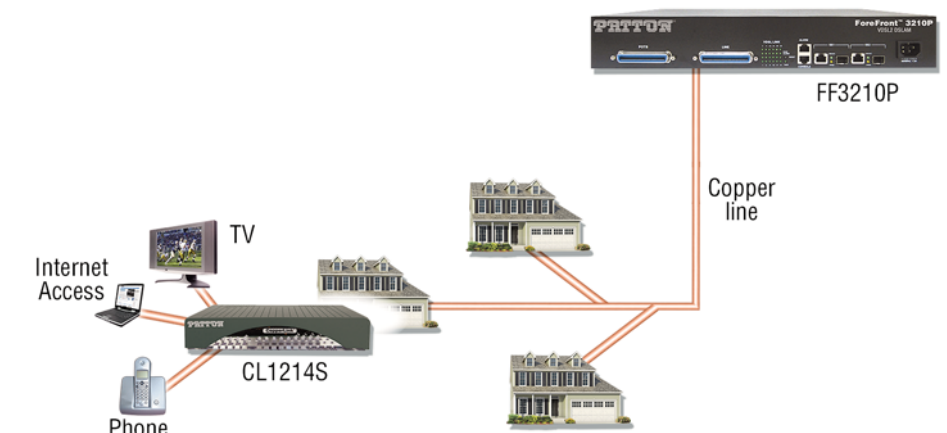

Solution Considerations



Multi-Drop Ethernet (MDE)

PLCs, access control panels, and sensors are commonly deployed in legacy RS-422/485 topologies. These devices are now readily available with Ethernet ports. Our Multi-Drop Extenders make it easy to switch out or replace legacy RS-422/485 controllers without having to change your existing cable or topology. A second-

ary benefit of the MDE units is that they also act as a repeater, doubling the reach with no loss in bandwidth.

- Ethernet PLC (Programmable Logic Controller) connectivity
- Legacy PLC replacement
- Ethernet BAC (Building Automation & Control) connectivity
- Ethernet sensor connectivity



Star + Multi-Drop Ethernet

The Star + MDE consists of a centrally located DSLAM or long range Ethernet (LRE) switch, and a CPE capable of Ethernet Multi-Drop function. The most common use cases for the Star + MDE are private campus and transportation, where users want to reuse existing twisted-pair infra-

structure to connect multiple PLCs, access control panels, and sensor nodes in multi-drop fashion.

- Hospitality
- Multi-Dwelling (MxU)
- Camp/Campus/Base
- Small service area broadband

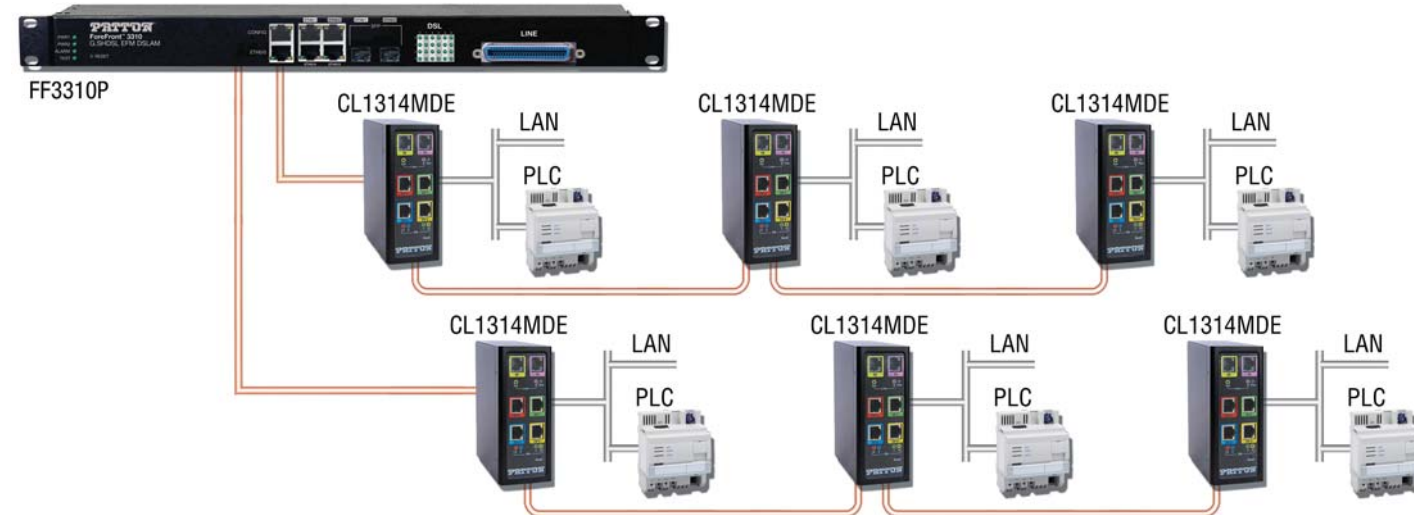

Ring (with MDE)

The Ring topology consists of at least 3 nodes. Each node is in turn connected to 2 nodes, providing a redundant and continuous path for various types of critical backhaul applications.

- Inter-building backhaul
- Camp/Campus/Base interconnect
- Industrial Control & Automation

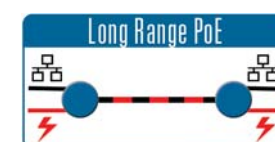
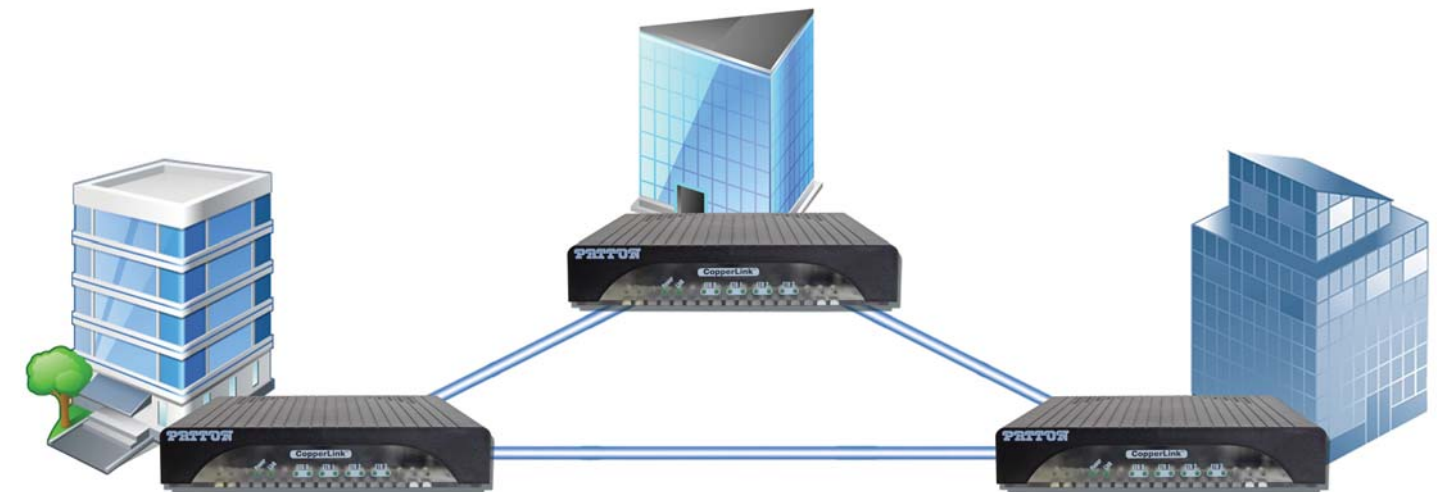

Long Reach Power over Ethernet

Power over Ethernet 802.3af/at is revolutionizing the already prolific uses of Ethernet. The ability to power and provide network connectivity over network cables

makes transitioning analog security and voice to all IP cost effective and simple. Patton's CL1101 takes this a step further by enabling you to use existing analog circuits (twisted-pair or coax) for high speed data and power!

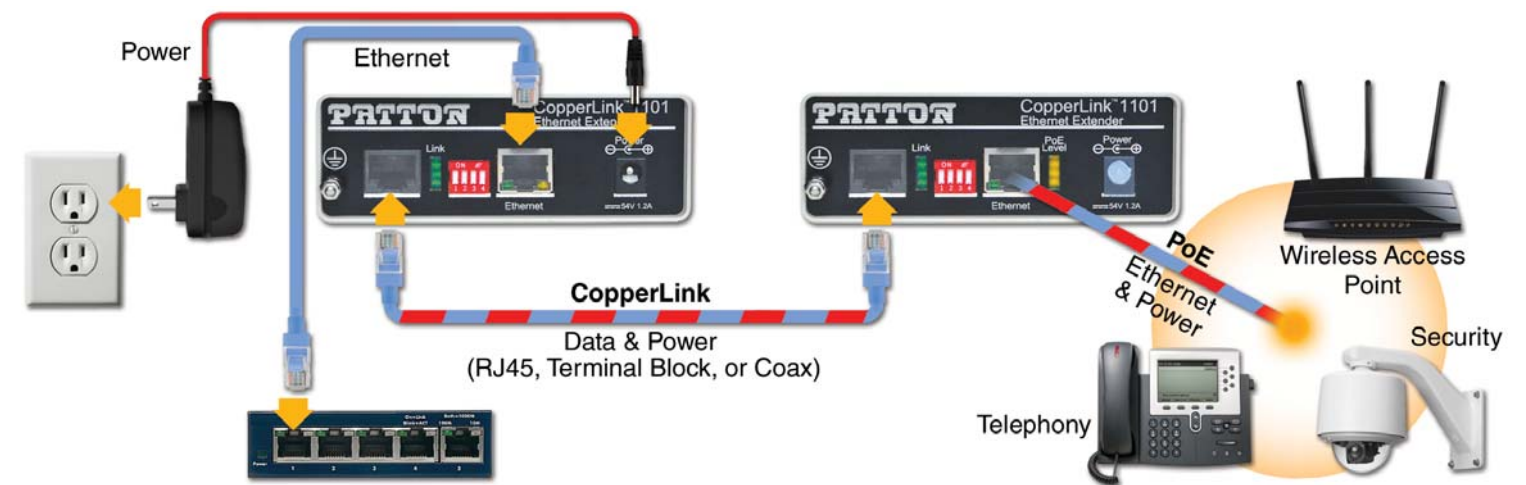

VoIP IAD Products



eSBC Router/IAD SmartNode™ 5570 Series

The cost-effective SmartNode 5570 Enterprise Session Border Controller (eSBC) Router/IAD provides 1 or 2 T1/E1/PRI ports with state-of-the-art security features. Transcoding for up to 16 SIP-to-SIP calls, high-definition G.722 codec, and QoS deliver optimum voice quality over IP.

Alternate product descriptions:

- **VDSL2/ADSL2+** T1/E1/PRI, SIP eSBC Router/IAD
- **G.SHDSL** T1/E1/PRI, SIP eSBC Router/IAD
- **Ethernet-over-Fiber** T1/E1/PRI, SIP eSBC Router/IAD

The SmartNode 5570 Series eSBC Router/IAD bridges a wide range of IP-PBX products to their SIP Trunk service providers. With its built-in Security features such as SIP TLS, SRTP, Stateful Firewall and Secure provisioning, it protects LAN networks from fraud strikes out of the Internet.

The unique Web Wizard, enables an easy and hassle-free installation, and enables technical people to create their own Web interface.

With the separate config domain feature, the SN5570 will be the service demarcation point for SIP Trunk service providers. Where the local administrator can only modify configuration settings facing the LAN IP PBX.

The SmartNode 5570 is the solution for service providers and network integrators looking for a VoIP product that matches up to ISDN standards in terms of features and quality and solves SIP to SIP interoperability issues.

	Number of Calls		
	Default (Ships with)	Max possible (upgradeable)	License (SKU)
Transcoded SIP to SIP calls	15	15	N/A
SIP to SIP calls (same codecs)	15	200	SNSW-1B
SIP to TDM (PRI)	15 or 30 (depending on model)	30	SNSW-49V1

Typical Application

Whether used as an Enterprise Session Border Router or as a VoIP gateway/router/IAD, the SmartNode 5570 provides excellent VoIP, IP QoS and security features for seamless network integration. All PRI ports are configurable to be TE or NT, so you can connect your PSTN line and an ISDN PRI PBX. For business class IP telephony at the tip of your fingers, the SmartNode SN5570 is more than just talk!

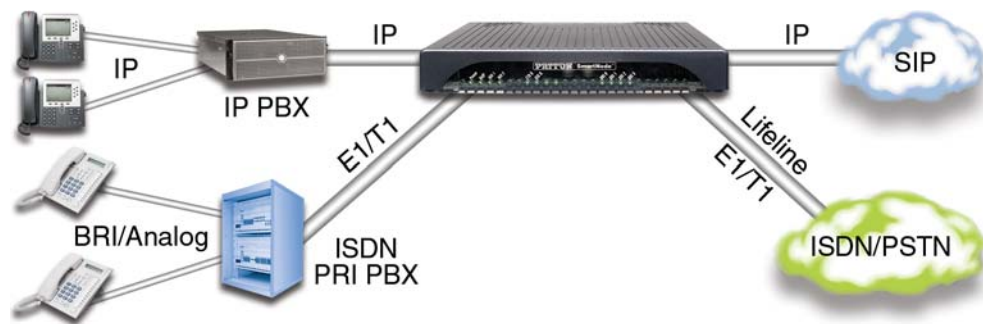

* Additional charges apply for licensed features.
** Depending on model.

*** Supports up to 512 SIP-to-SIP sessions under ideal conditions. Transcoding, debugging, and/or IP routing reduce processing capacity.

FEATURES & BENEFITS

- ✓ **Supports 30 VoIP calls**—1 or 2 ISDN E1/T1 PRI ports. 30 simultaneous G.722, T.38 or G.711 ISDN to VoIP calls. Including SIP TLS and SRTP support for 30 calls.
Or up to 16 SIP-to-SIP transcoded calls (e.g. G.711 to G.722 or RTP to SRTP)
- ✓ **Full VoIP protocol support**—SIPv2, SIPv2 over TLS, ISDN, DSS1, NI-2, QSIG*, T.38, G.722 HD voice, RTP Security with SRTP, fax and modem bypass, DTMF relay. SIP to SIP transcoding for up to 15 calls, non transcoding up to 512*** calls.
- ✓ **Full Telephony Features**—SessionRouter allows flexible call routing and numbering plan adaptations, CLIP/CLIR, hold, transfer, 3-way conferencing (Roadmap) and much more.
- ✓ **SIP Registrar**—License is included in all eSBC products.
- ✓ **Complete Access Routing**—Two 10/100/1000 Ethernet ports with auto MDI-X. Ethernet Layer 2 switching and bridging. Access router with NAT, Policy Based Routing, Stateful Firewall, PPPoE, DHCP, DynDNS.
- ✓ **Access link redundancy**—USB for 3G/4G IP failover & load balancing, and TDM failover using second T1/E1 port.
- ✓ **Management & Provisioning**—Web-based management, Web Wizard, SNMPv3, command line interface, auto-provisioning, separate config domain support, secure provisioning for configuration & software upgrades.
- ✓ **Outstanding Interoperability**—Interoperable for voice and T.38 fax with leading SIP service providers, softswitch vendors, and Asterisk™ IP-PBX.
- ✓ **High Precision Clock (HP) Option**—DECT PBX interoperability and improved fax performance with Stratum 3 CO quality clock (HP)**.

ORDERING INFORMATION

Obtain ordering info for this product by using the QR code at right or by contacting:

- email: sales@patton.com
- tel: +1 301.975.1000
- web: http://www.patton.com/products/product_detail.asp?id=522&tab=Ordering



eSBC Router/IAD SmartNode™ 5551

2 BRI/2 FXS or 4 BRI/4 FXS ports and 4–8 simultaneous G.722/G.711 or T.38 calls. The SN5551 is the best way to connect ISDN networks or ISDN terminal equipment, and legacy analog equipment into an ALL-IP environment. With built-in security features such as HTTPS provisioning, Stateful Firewall, and SIP-TLS/SRTP** it provides business-class VoIP for demanding ISDN users.

Alternate product descriptions:

- **VDSL2/ADSL2+** FXS+BRI, SIP eSBC Router/IAD
- **G.SHDSL** FXS+BRI, SIP eSBC Router/IAD
- **Ethernet-over-Fiber** FXS+BRI, SIP eSBC Router/IAD

The SmartNode 5551 Enterprise Session Border Controller (eSBC) bridges a wide range of IP-PBX products to their SIP Trunk service providers. With its built-in security features such as SIP TLS, SRTP, Stateful Firewall and secure provisioning, it protects the LAN networks from fraud strikes out of the Internet.

The combo configuration of 2 BRI/2 FXS or 4 BRI/4 FXS, fits the requirements of small and medium sized enterprises requiring a solution to enable legacy equipment for VoIP networks.

The unique Web Wizard enables easy and hassle-free installations, and enables technical people to create their own Web interface.

With the separate config domain feature, the SN5551 will be the service demarcation point for SIP trunk service providers, so the local administrator only has to modify configuration settings facing the LAN IP-PBX.

	Number of Calls		
	Default (Ships with)	Max possible (upgradeable)	License (SKU)
Transcoded SIP to SIP calls	2	4	SNSW-TC
SIP to SIP calls (same codecs)	4	200	SNSW-1B
SIP to TDM (PRI)	4	8	SNSW-49V1

Typical Application

Whether used as an enterprise session border controller or as a VoIP gateway/router, the SmartNode 5551 provides excellent VoIP, IP QoS and security features for seam-less network integration. With BRI and analog ports, the SN5551 converts modem and fax signals to VoIP, and solves problems with integrating PoS, metering systems, elevator phones, etc. to an ALL-IP environment. For business class IP telephony at the tip of your fingers, the SmartNode 5551 is more than just talk!

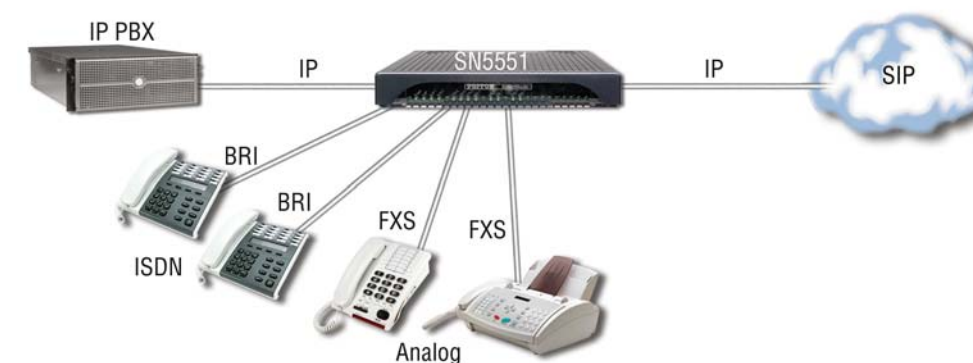

* Additional charges apply for licensed features.
** Depending on model.

*** Supports up to 256 SIP-to-SIP sessions under ideal conditions. Transcoding, debugging, and/or IP routing reduce processing capacity.

FEATURES & BENEFITS

- ✓ **BRI & FXS interfaces**—2 or 4 ISDN BRI SO/T0 and 2 or 4 FXS ports. 4–8 G.722/G.711 or 4 T.38 calls simultaneously. Includes SIP TLS/SRTP.
- ✓ **Advanced Local Call Switching**—Virtual interfaces and routing tables provide industry leading flexibility in call handling programming. Local call switching, soft fall-back to alternative routes. Simultaneously connects to multiple SIP services/IP PBXs.
- ✓ **Network Monitoring**—Embedded Packet Smart Agent for network monitoring and assessment 24x7.***
- ✓ **Auto-Provisioning**—Secure zero-touch provisioning (HTTPS) for ease of use.
- ✓ **Proprietary OS**—Utilizes proprietary Trinity software for enhanced security.
- ✓ **Access link redundancy**—USB for 3G/4G IP failover & load balancing
- ✓ **Ease of Use**—Patton's Web Wizard is a time saving tool for a fast and reliable installation.
- ✓ **Full VoIP protocol support**—SIPv2, SIPv2 over TLS, ISDN, DSS1, QSIG**, T.38, G.722 HD voice, RTP Security with SRTP, fax and modem bypass, DTMF relay.
- ✓ **Outstanding Interoperability**—Interoperable for voice and T.38 fax with leading SIP service providers, softswitch vendors, and major IP-PBX manufacturers.

ORDERING INFORMATION

Obtain ordering info for this product by using the QR code at right or by contacting:

- email: sales@patton.com
- tel: +1 301.975.1000
- web: http://www.patton.com/products/product_detail.asp?id=538&tab=Ordering





eSBC Router/IAD SmartNode™ 5540 Series

The SmartNode 5540 Series of Enterprise Session Border Controller (eSBC) Router/IADs (with analog interfaces) supports up to 8 telephone connections integrating legacy equipment in to a UCC environment. High quality voice and reliable fax over any IP network. ALL-IP does not end when analog terminals have to be integrated. Security and quality guaranteed.

Alternate product descriptions:

- **VDSL2/ADSL2+** Analog (FXS/FXO), SIP eSBC Router/IAD
- **G.SHDSL** Analog (FXS/FXO), SIP eSBC Router/IAD
- **Ethernet-over-Fiber** Analog (FXS/FXO), SIP eSBC Router/IAD

Connect with confidence using the SmartNode 5540 Series eSBC with an integrated enterprise router to the local PSTN and/or the SIP Trunk service. The SN5540 supports 8 simultaneous calls for a new standard in toll-bypass, remote/branch office connectivity, and enhanced ALL-IP carrier services.

The SN5540 acts as VoIP gateway, eSBC, access router/IAD and QoS CPE all in one device. It can also undertake network assessment and monitoring at the customer premise utilizing the PacketSmart™ agent to prevent, reduce, and resolve network and voice quality problems.

	Number of Calls		
	Default (Ships with)	Max possible (upgradeable)	License (SKU)
Transcoded SIP to SIP calls	2	4	SNSW-TC
SIP to SIP calls (same codecs)	4	200	SNSW-1B
SIP to TDM (PRI)	4	8	SNSW-49V1

Typical Application

Whether used as an Enterprise Session Border Controller, as a VoIP gateway or IP router, the SmartNode 5540 provides excellent VoIP, IP QoS, and security features for seamless network integration.

Thanks to the built-in FXS ports, it resolves technology evolution related problems, either by integrating old, non-replaceable telephones into a UCC environment, or for good old fax devices to be migrated to the next-generation network infrastructure.

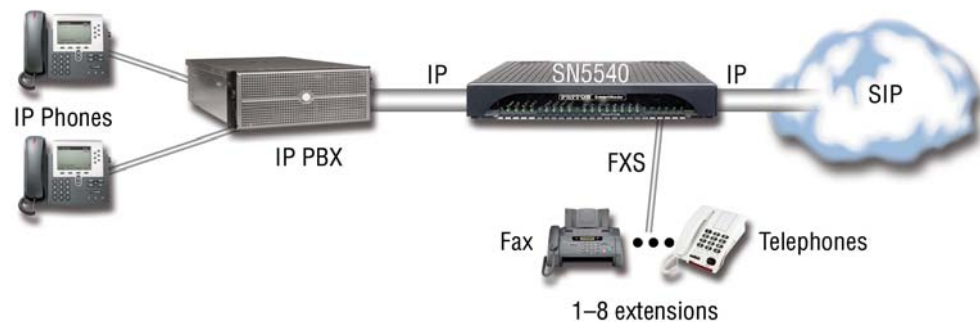

FEATURES & BENEFITS

- ✓ **2-8 FXS or FXO (8 TDM calls) interfaces**—2, 4 or 8 FXS ports. Up to 8 G.722/G.711 or T.38 calls simultaneously. Includes SIP TLS/SRTP.
- ✓ **Advanced Local Call Switching**—Virtual interfaces and routing tables provide industry leading flexibility in call handling programming. Local call switching, soft fallback to alternative routes. Simultaneously connects to multiple SIP services/IP PBXs.
- ✓ **Network Monitoring**—Embedded Packet Smart Agent for network monitoring and assessment 24x7.
- ✓ **Auto-Provisioning**—Secure zero-touch provisioning (HTTPS) for ease of use.
- ✓ **Access link redundancy**—Through USB port, using 3G/4G Cellular Modem module
- ✓ **Proprietary OS**—Utilizes proprietary Trinity software for enhanced security.
- ✓ **Easy Management & Provisioning**—Web Wizard, HTTPS zero touch provisioning, SNMP, command line interface. Automated mass provisioning with dual software image for efficient large-scale deployments
- ✓ **Full VoIP protocol support**—SIPv2, SIPv2 over TLS, ISDN, T.38, G.722 HD voice, RTP Security with SRTP, fax and modem bypass, DTMF relay.
- ✓ **Outstanding Interoperability**—Interoperable for voice and T.38 fax with leading SIP service providers, softswitch vendors, and major IP-PBX manufacturers.

ORDERING INFORMATION

Obtain ordering info for this product by using the QR code at right or by contacting:

- email: sales@patton.com
- tel: +1 301.975.1000

• web: http://www.patton.com/products/product_detail.asp?id=541&tab=Ordering



* Depending on mode
** Licensed feature at additional charge

*** Supports up to 200 SIP-to-SIP sessions under ideal conditions. Transcoding, debugging, and/or IP routing reduce processing capacity.



eSBC Router/IAD SmartNode™ 5530 Series

The cost-effective SmartNode 5530 Series Enterprise Session Border Controller (eSBC) Router/IAD provides 2, 4 or 8 BRIs with secure TLS and SRTP encryption. The SN5530 guarantees excellent voice quality with transcoding for up to 8 SIP-to-SIP calls, QoS, and high-definition G.722 codec support.

Alternate product descriptions:

- **VDSL2/ADSL2+** BRI SIP eSBC Router/IAD
- **G.SHDSL** BRI SIP eSBC Router/IAD
- **Ethernet-over-Fiber** BRI SIP eSBC Router/IAD

The SmartNode 5530 eSBC comes with built-in security features such as SIP-TLS, SRTP, Stateful Firewall and secure provisioning, to protect the LAN networks from fraud strikes out of the Internet.

The unique Web Wizard enables an easy and hassle free installation, and gives the possibility to technical people creating their own Web interface.

With the separate config domain feature, the SN5530 will be the service demarcation point for SIP Trunk service providers. Where the local administrator can only modify configuration settings facing the LAN IP PBX.

The 5530 can also be used to do VoIP call transcoding for up to 8 calls. For instance converting G711 codecs on the LAN side to G729 on the WAN side.

Like every SmartNode, the 5530 models are state-of-the-art eSBCs that also provide complete Policy Based IP routing.

	Number of Calls		
	Default (Ships with)	Max possible (upgradeable)	License (SKU)
Transcoded SIP to SIP calls	2	4	SNSW-TC
SIP to SIP calls (same codecs)	4	200	SNSW-1B
SIP to TDM (PRI)	4	8	SNSW-49V1

Typical Application

Whether used as an Enterprise Session Border Router or as a VoIP gateway/router, the SmartNode 5530 provides excellent VoIP, IP QoS and security features for seamless network integration. All BRI ports are configurable to be TE or NT, you can thus connect your telco line(s) as well as a PBX or ISDN terminals. Terminals are powered with the built-in power supply, eliminating the need for an external box. For business class IP telephony at the tip of your fingers, the SmartNode 5530 is more than just talk!

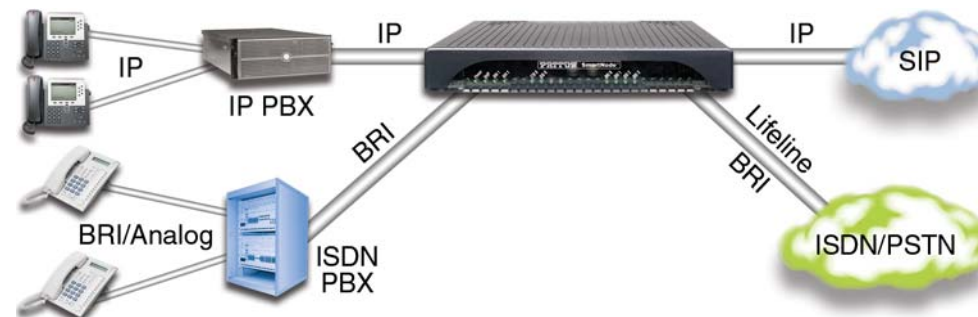

* Depending on model
** Licensed feature at additional charge

*** Supports up to 200 SIP-to-SIP sessions under ideal conditions. Transcoding, debugging, and/or IP routing reduce processing capacity.

FEATURES & BENEFITS

- ✓ **Quality ISDN VoIP**—2, 4 or 8 ISDN BRI SO ports. Up to 16 G.722 or up to 16 T.38 or G.711 calls simultaneously. Using SRTP, up to 10 simultaneous calls.
- ✓ **Full Telephony Features**—SessionRouter™ allows flexible call routing and numbering plan adaptations, CLIP/CLIR, hold, transfer, 3-way conferencing (Roadmap) and much more.
- ✓ **SIP Registrar**—License is included in *all* eSBC products.
- ✓ **Management & Provisioning**—Web-based management, Web Wizard, SNMPv3, command line interface, auto-provisioning separate config domain support, secure provisioning for configuration and software upgrades.
- ✓ **Complete Access Routing**—Two 10/100/1000 Ethernet ports with auto MDI-X. Ethernet Layer 2 switching and bridging. Access router with NAT, Policy Based Routing, Stateful Firewall, PPPoE, DHCP, DynDNS.
- ✓ **Access link redundancy**—USB for 3G/4G IP failover & load balancing
- ✓ **Full VoIP protocol support**—SIPv2, SIP v2 over TLS, ISDN, DSS1, QSIG***, T.38, G.722 HD voice, RTP Security with SRTP, fax and modem bypass, DTMF relay. SIP to SIP transcoding for up to 4 calls.
- ✓ **Outstanding Interoperability**—Interoperable for voice and T.38 fax with leading SIP service providers, softswitch vendors, and Asterisk™ IP-PBX.
- ✓ **High Precision Clock (HP) Option**—DECT PBX interoperability and improved fax performance with Stratum 3 CO quality clock (HP)**.
- ✓ **Supported by SmartNode™ Redirection Service**—A free service enabling zero-touch mass deployments for Service Providers and Distributors with auto-provisioning servers

ORDERING INFORMATION

Obtain ordering info for this product by using the QR code at right or by contacting:

- email: sales@patton.com
- tel: +1 301.975.1000

• web: http://www.patton.com/products/product_detail.asp?id=520&tab=Ordering





eSBC Router/IAD SmartNode™ 5501

The SmartNode 5500 Series of Enterprise Session Border Controllers (eSBC) supports up to 200 SIP-to-SIP calls (up to 16 of which can be transcoded SIP to SIP calls). Service demarcation is key for high quality and reliable services, even in ALL-IP networks. State-of-the-art security and quality guaranteed.

Alternate product descriptions:

- VDSL2/ADSL2+ Router
- G.SHDSL.bis EFM/ATM Router

Connect with confidence using the SmartNode 5500 Series eSBC with an integrated enterprise router to a SIP trunk or hosted PBX service. The SN5500 supports up to 200 SIP to SIP calls—16

out of which can be codec transcoded—for reliable remote/branch office connectivity, and enhanced ALL-IP carrier services.

The SN5500 acts as eSBC, access router, and QoS CPE all in one device. It can also undertake network assessment and monitoring at the customer premise utilizing the PacketSmart™ agent to prevent, reduce, and resolve network and voice quality problems.

	Number of Calls		
	Default (Ships with)	Max possible (upgradeable)	License (SKU)
Transcoded SIP to SIP calls	0	0	SNSW-TC
SIP to SIP calls (same codecs)	4	200	SNSW-1B
SIP to TDM (PRI)	4	8	SNSW-49V1

Applications

Whether used as an Enterprise Session Border Controller or IP router, the SmartNode 5500 provides excellent VoIP, IP QoS, and security features for seamless network integration.

Thanks to the built-in SIP back-to-back user agent, it resolves technology evolution related problems by normalizing SIP traffic from different vendor implementations. In addition, enhanced security is given to the enterprise thanks to various features protecting the LAN infrastructure. Number manipulation and call routing options come standard with every Patton eSBC.

SIP Trunk Application

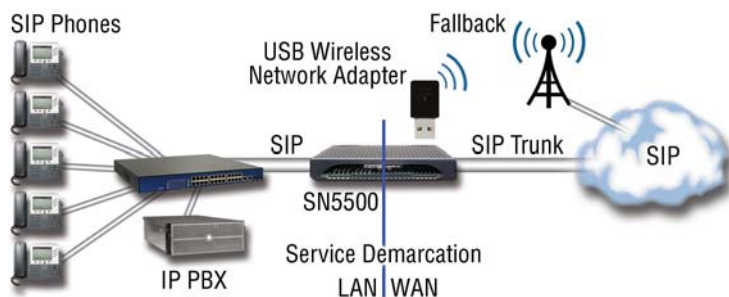

SIP Hosted Application

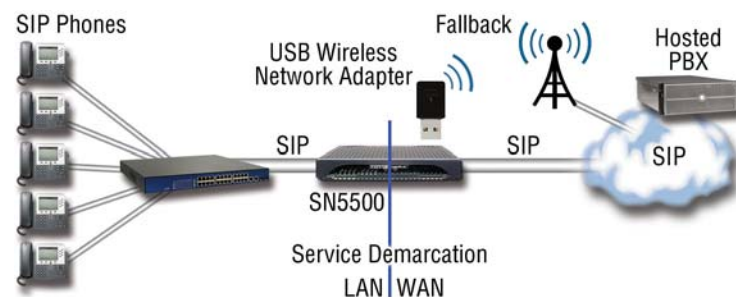

FEATURES & BENEFITS

- ✓ **IP Routing**—Policy Based Routing; Protocol Based Routing; Packet Length Routing; Packet Filtering
- ✓ **Advanced Local Call Switching**—Virtual interfaces and routing tables provide industry leading flexibility in call handling programming. Local call switching, soft fallback to alternative routes. Simultaneously connects to multiple SIP services/IP PBXs. Includes SIP TLS/SRTP.
- ✓ **Network Monitoring**—Embedded Packet Smart Agent for network monitoring and assessment 24x7.
- ✓ **Auto-Provisioning**—Secure zero-touch provisioning (HTTPS) for ease of use.
- ✓ **Proprietary OS**—Utilizes proprietary Trinity™ software for enhanced security.
- ✓ **Easy Management & Provisioning**—Managed-CLI, Web Wizard, HTTPS zero touch provisioning, TR-069, SNMP, command line interface. Automated mass provisioning with dual software image for efficient large-scale deployments.
- ✓ **Access link redundancy**—USB for 3G/4G IP failover & load balancing
- ✓ **Full VoIP protocol support**—SIPv2, SIPv2 over TLS, T.38, G.722 HD voice, RTP Security with SRTP, fax and modem bypass, DTMF relay.
- ✓ **Outstanding Interoperability**—Interoperable for voice and T.38 fax with leading SIP service providers, softswitch vendors, and major IP-PBX manufacturers.



eSBC Router/IAD SmartNode™ 5490

Providing up to 64 transcoded calls, the SmartNode™ 5490 session border controller with built-in WAN router connects the wide range of IP PBX products to their service providers ensuring security and a high level of efficiency in the VoIP network.

Alternate product descriptions:

- VDSL2/ADSL2+ ALL-IP SIP eSBC Router/IAD
- G.SHDSL ALL-IP SIP eSBC Router/IAD
- Ethernet-over-Fiber ALL-IP SIP eSBC Router/IAD
- VDSL2/ADSL2+ Router
- G.SHDSL.bis EFM/ATM Router

The SmartNode 5490 Enterprise Session Border Controller (eSBC) Router/IAD with built-in WAN broadband access is a single integrated platform that bridges the wide range of IP PBX products to their service providers ensuring security and a high level of efficiency in the VoIP network. Connecting the Enterprise's LAN to an Internet Telephony Service Provider (ITSP), the SN5490

creates a single conduit for multimedia components including voice, video and data. Evolving from Patton's award winning SmartNode 5400 Series, the next generation SmartNode 5490 Series comes now with IPv6 upgradeable hardware.

Through the SIP Back-to-Back User Agent, the SN5490 provides a common interface into the service provider network providing resolution of any differences between the SIP from the IP PBX and the service provider softswitch. Additionally, the SN5490 provides CODEC transcoding for up to 64 SIP sessions insuring the most efficient use of available bandwidth for both voice and data. Reduce WAN-access bandwidth requirements by converting high-bandwidth G.711 calls on your LAN into lower-bandwidth G.723 calls for WAN transport.

For additional security, the SN5490 includes SIP-aware NAT and access controlled lists (ACLs) for maintaining secure communications when SIP traffic crosses the Enterprise edge. In addition, routing capabilities include RIP v1/v2, virtual router redundancy protocol (VRRP), loopback interfaces as well as advanced techniques like policy based routing (PBR). Furthermore, QoS keeps malicious traffic from effecting bandwidth requirements of PBR-marked essential traffic and Downstream QoS ensures important voice and fax calls do not get bogged down by such resource hungry lower priority TCP traffic as FTP downloads.

For survivability, the SN5490 is equipped with a link status based routing function. This function, together with SIP registrar, enables survivable telephony services to be deployed between intra-office SIP clients in case there is a failure at the SIP provider.

	Number of Calls		
	Default (Ships with)	Max possible (upgradeable)	License (SKU)
Transcoded SIP to SIP calls	2	64	SNSW-TC
SIP to SIP calls (same codecs)	4	80	SNSW-1B

Typical Application



FEATURES & BENEFITS

- ✓ **Trinity OS**—Optional, select this when SIP TLS/SRTP is required.
- ✓ **VoIP Transcoding**—Capacity for up to 64 SIP-SIP calls with transcoding and up to 128 SIP Sessions without transcoding.
- ✓ **WAN Access**—Fiber SFP, G.SHDSL, EFM, Serial X.21, or ADSL WAN interface.
- ✓ **IP Routing**—RIP v1/v2, VRRP, Policy Based Routing, Loopback/Virtual Interface, NAPT-capable edge router.
- ✓ **QoS and Security**—Deliver secure, toll-quality voice communications with Patton's DownStreamQoS™ with adaptive traffic management and shaping—plus secure voice-over-VPN with AES/DES strong encryption and extended ACL capabilities.
- ✓ **SIP Registrar**—License is included in ALL eSBC products.
- ✓ **10/100/1000 Ethernet**—One 10/100/1000 WAN Ethernet port and one 10/100/1000 LAN Ethernet port.
- ✓ **Proprietary Software**—Utilizes proprietary SmartWare™ Software for added security.
- ✓ **Flexible mounting options**—The device can be placed on a desktop or installed in a 19-inch rack using the optional rack ear kit (INS-KIT-RACKEARS-11/19)

ORDERING INFORMATION

Obtain ordering info for this product by using the QR code at right or by contacting:

- email: sales@patton.com
- tel: +1 301.975.1000
- web: http://www.patton.com/products/product_detail.asp?id=469&tab=Ordering





eSBC Router/IAD SmartNode™ 5300

Providing up to 128 SIP Sessions, the SN5300 session border controller router is a SIP eSBC that ensures VoIP security using SIP TLS, providing superior voice quality using the built-in QoS engine.

Alternate product description:

- G.SHDSL ALL-IP SIP eSBC Router/IAD

The SN5300 enables protocol conversion between two networks to solve interop problems for devices using SIP TCP signaling only. The SmartNode is able to convert SIP TCP or SIP TLS signaling into SIP UDP signaling.

Using the built-in QoS engine, the SmartNode ensures that voice traffic gets top priority resulting in good voice quality across the SIP Trunk over a public network.

Using the built-in QoS engine, the SmartNode ensures that voice traffic gets top priority resulting in good voice quality across the SIP Trunk over a public network.

	Number of Calls		
	Default (Ships with)	Max possible (upgradeable)	License (SKU)
Transcoded SIP to SIP calls	0	0	SNSW-TC
SIP to SIP calls (same codecs)	4	60	SNSW-1B
SIP to TDM (PRI)	0	0	

Typical and EFM Applications

The SN5300 enables protocol conversion between two networks to solve interop problems for devices using SIP TCP signaling only. The SmartNode is able to convert SIP TCP or SIP TLS signaling into SIP UDP signaling.

Using the built-in QoS engine, the SmartNode ensures that voice traffic gets top priority resulting in good voice quality across the SIP Trunk over a public network.

FEATURES & BENEFITS

- ✓ **IP Routing**—Policy Based Routing, Protocol Based Routing, Packet Length Routing, Packet Filtering
- ✓ **QoS and Security**—Deliver secure, toll-quality voice communications with Patton's UpStreamQoS with adaptive traffic management and shaping as well as policy based routing and extended ACL capabilities.
- ✓ **SIP Registrar**—License is included in ALL eSBC products.
- ✓ **Ethernet**—Intelligent 4-port Fast Ethernet Base-T 10/100 (routable and switchable)
- ✓ **WAN Access**—Support for G.SHDSL EFM/ATM 4-wire and 8-wire interfaces
- ✓ **Access link redundancy**—Through USB port, using 3G/4G Cellular Modem module
- ✓ **Trinity OS**—Patton's Linux-based multi-service OS with call-control and signaling features
- ✓ **Flexible mounting options**—Desktop and integrated wall-mount options in a compact modern enclosure.
- ✓ **Supported by SmartNode™ Redirection Service**—A free service enabling zero-touch mass deployments for Service Providers and Distributors with auto-provisioning servers.

Typical Application



Typical EFM Application

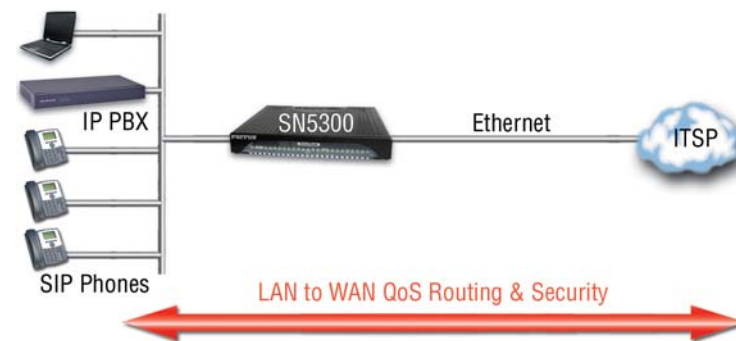

ORDERING INFORMATION

Obtain ordering info for this product by using the QR code at right or by contacting:

- email: sales@patton.com
- tel: +1 301.975.1000
- web: http://www.patton.com/products/product_detail.asp?id=502&tab=Ordering



sales@patton.com | www.patton.com

Key words you should know...

ADSL—Asymmetric Digital Subscriber Line

ATM—Asynchronous Transfer Mode

CPE—Customer Premises Equipment.

Downstream—In the direction of the customer premises.

EAD—Ethernet Access Devices

EoC—Ethernet over Copper Devices

eSBC—Enterprise Session Border Controller.

G.SHDSL—G.SHDSL, or SHDSL, offers bitrates from 192 kbps to 15.3 Mbps over a 2-wire single pair and up to 60 Mbps over four bonded pairs.

IAC—Integrated Access Concentrator.

IP—Internet Protocol.

IPsec—Internet Protocol Security

ISDN—Integrated Services Digital Network.

ISR—Integrated Services Routers

LAN—Local Area Network

MSBR—Multiservice Business Routers

MCU—Multi-Commercial Unit.

MDU—Multi-Dwelling Unit.

MSAR—Multiservice Access Routers

MTU—Multi-Tenant Unit

PSTN—Public Switched Telephone Network.

SFP—Small Form-factor Pluggable.

TC-PAM—Trellis-Coded Pulse-Amplitude Modulation

Upstream—In the direction of the telephone network or server.

VDSL2—Very High Bit Rate Digital Subscriber Line 2

WAN—Wide Area Network

xDSL—All generations of DSL transmission technology



Get the full VoIP Glossary. It's free!

This glossary provides plain language explanations of VoIP and telecommunications terms.

Download it here:
www.patton.com/glossary



Multiport Enterprise IAD

SmartNode™ 4990

Now service providers can reach **more** enterprise subscribers with ALL-IP services. The SmartNode 4990 VoIP IAD connects any existing telephony system to SIP trunks and the PSTN.

Alternate product descriptions:

- G.SHDSL ALL-IP SIP eSBC Router/IAD
- VDSL2/ADSL2+ ALL-IP SIP eSBC Router/IAD
- VDSL2/ADSL2+ Router
- Ethernet-over-Fiber ALL-IP SIP eSBC Router/IAD
- G.SHDSL.bis EFM/ATM Router

The SmartNode™ 4990 VoIP Integrated Access Device for 15-to-120 VoIP calls lets enterprises graduate to ALL-IP at their own pace. The one-box solution includes a built-in G.SHDSL-EFM/ATM, VDSL/ADSL, fiber, or X.21 WAN interface for broadband access. Legacy telephony interfaces enable SIP trunk providers to offer their ALL-IP services to businesses that want to keep an existing

PBX solution, while providing PSTN connectivity for voice and data survivability.

The integrated WAN-access options reduce CPE costs, simplify network architecture, and accelerate service deployment. A SIP back-to-back user agent provides SIP normalization that ensures interoperability between any customer PBX and any provider softswitch on the market. Built on a platform that is ready to support IPv6, the SN4990 provides secure TLS and SRTP encryption* while supporting all the industry-standard CODECs for toll-quality voice on every call.

The Unified Communications Agent™ (UCA) provides any-to-any multi-path switching (simultaneous SIP, H.323, ISDN, and POTS calls with routing and conversion between TDM/PSTN and IP/Ethernet networks—plus T.38 and SuperG3 FAX). VoIP-over-VPN technology (with voice encryption) provides secure voice and data via IPsec with AES/DES strong encryption and automated keying via Internet Key Exchange (IKE) and OpenVPN*. Advanced call-router functionality includes least-cost call routing with flexible dialed-number plan support.

The SmartNode survivability suite combines PSTN fallback, SIP Registrar, IP-link redundancy and active SIP server reachability detection to ensure business continuity in case the IP network fails, while Patton's DownStreamQoS™ delivers clear, uninterrupted voice-and-data communication. Patton's unique high-precision clock delivers first-line IP-telephony service in demanding ISDN and DECT environments—with reliable FAX and modem performance.

The SN4990 delivers secure, prioritized unified communications with one to four T1/E1/PRI and two 10/100/1000 Ethernet ports—plus broadband access—in a single box. An optional third 10/100 Ethernet port may connect to an out-of-band IP management network, or—for enhanced survivability—provide a redundant Ethernet connection to the (same or alternate) service provider.

	Number of Calls		
	Default (Ships with)	Max possible (upgradeable)	License (SKU)
Transcoded SIP to SIP calls	0	64	SNSW-TC
SIP to SIP calls (same codecs)	4	80	SNSW-1B
SIP to TDM (PRI)	15–120	120	SNSW-49V1

FEATURES & BENEFITS

- ✓ Trinity OS—Optional, select this when SIP TLS/SRTP is required. Software Comparison
- ✓ 15 to 120 VoIP calls—with up to four T1/E1/PRI ports and dual Gigabit Ethernet ports.
- ✓ Survivability—PSTN failover using ISDN lines or alternate WAN link. SIP server health detection with instant failover call routing. SIP registrar for local calling during failover.
- ✓ QoS and Security—Deliver secure, toll-quality voice communications with Patton's DownStreamQoS™, Fraud prevention, secure voice-over-VPN with IPsec, OpenVPN.
- ✓ WAN Access—Fiber SFP, G.SHDSL-EFM/ATM, Serial X.21, Fast Ethernet or VDSL/ADSL WAN interface.
- ✓ SIP Interop and Normalization—SIP interop with major IP PBX, softswitch and VoIP service providers. Over 100,000 SmartNode deployments worldwide. ISDN/PSTN compliance in nearly every country.
- ✓ High Precision Clock—Delivers DECT PBX interoperability with reliable fax performance.
- ✓ VoIP Transcoding Option—Up to 60 channels for WAN bandwidth optimization.
- ✓ Transparent Telephony Features—Complex number manipulation and mapping for seamless integration with existing infrastructures, CLIP, CLIR, hold, transfer and much more.
- ✓ Flexible Mounting Options—The device can be placed on a desktop or installed in a 19-inch rack using the optional rack ear kit (INS-KIT-RACKEARS-11/19).
- ✓ Supported by SmartNode™ Redirection Service: A free service enabling zero-touch mass deployments for Service Providers and Distributors with auto-provisioning servers.

ORDERING INFORMATION

Obtain ordering info for this product by using the QR code at right or by contacting:

- email: sales@patton.com
- tel: +1 301.975.1000
- web: http://www.patton.com/products/product_detail.asp?id=467&tab=Ordering



General Applications Overview

- IP-enabled ISDN PBX
- Survivability & PSTN fallback
- QoS and IP routing

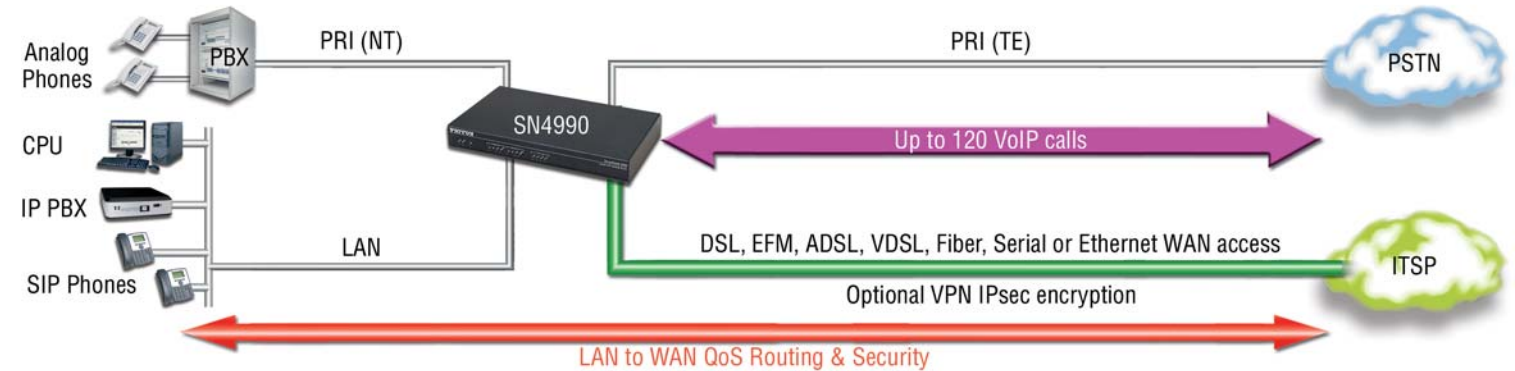

Migration to ALL-IP with Backup Link for Fallback

- IP PBX coexistent with legacy PBX
- SIP service monitoring & failover to PSTN

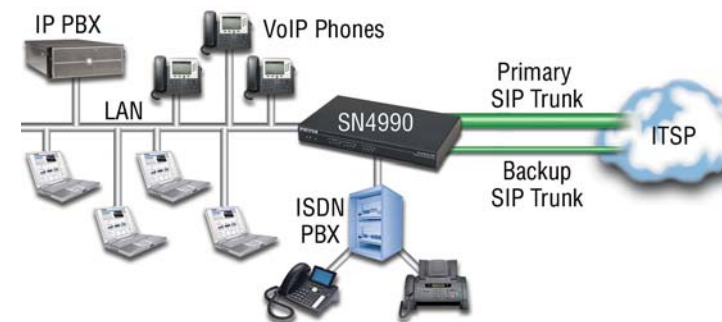

Migration to ALL-IP with Fallback to Alternate Service Provider

- IP PBX coexistent with legacy PBX
- Failover to secondary/alternate service provider over alternate WAN link



Migration to ALL-IP with Local Management & Monitoring

- ISDN to ALL-IP migration
- IP routing with QoS
- Separate Ethernet port for local monitoring and management

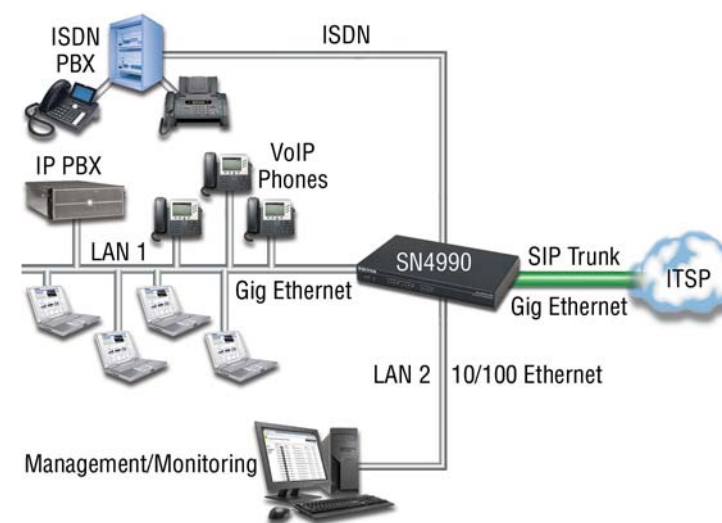

*These features are available in Trinity OS, but not in SmartWare.

Migration to ALL-IP with Out-of-band Management

- ISDN to ALL-IP migration
- IP routing with QoS
- Separate Ethernet port for remote, out-of-band monitoring and management

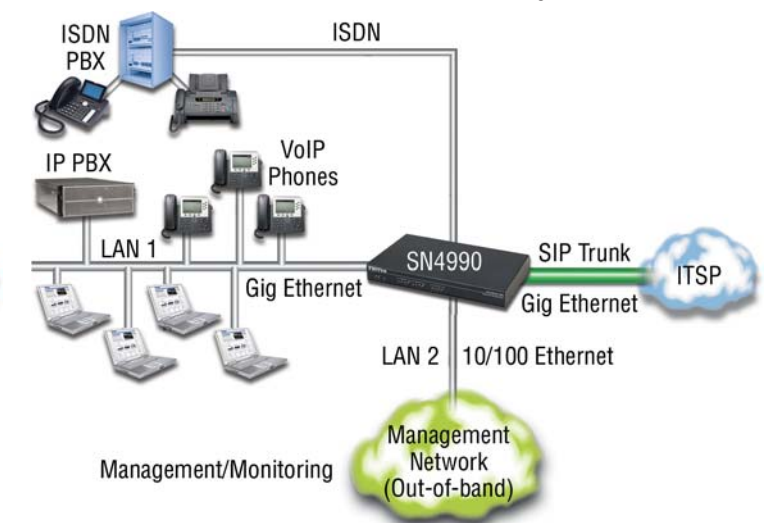

** Additional charges apply for licensed features.
*** Depending on model.

**** Supports up to 192 SIP-to-SIP sessions under ideal conditions. Transcoding, debugging, and/or IP routing reduce processing capacity.

EFM IAD, Bridge, Router & CPE Products



G.SHDSL.bis EFM IAD OnSite™ 3300 Series

Pair bonding support of up to 4 twisted-pairs (8-wire), multiple bandwidth options, and strong software suite makes the Patton OS3300 the ideal integrated access device (IAD) for service providers looking to replace E1/T1 service with high speed Metro Ethernet E-Line, E-LAN, or E-Tree services over copper.

Alternate product description:

- G.SHDSL.bis EFM/ATM Router

Patton's Model 3300 is a cost effective G.SHDSL.bis EFM IAD capable of achieving over 22 Mbps symmetrical line rates. The OnSite 3300's are the ideal choice for providing internet access to bandwidth hungry small to medium size offices, wireless backhaul, Metro Ethernet, even LAN to LAN extensions.

The OS3300 is cable of bonding from 1 to 4 pairs to increase overall bandwidth. Each pair is capable of up to 5.7 Mbps. The ability to configure both pair bonding allows both service providers and business to choose the best available rate vs. reach options available. The OS3300 can be set to auto rate mode, which will allow the OS3300 to automatically select the best rate achievable or manual fixed line rate mode. The OS3300 supports different rates on the pairs of a bundle. The traffic remains in case of line-faults, as long as at least one pair of a bundle is operating.

QoS configurations ease the bandwidth management of ports and applications through the creation of QoS classes and profiles. Traffic can be shaped and policed to provide full QoS control over both the egress and ingress directions.

ToS bits can be re-stripped to ensure network-wide QoS enforcement. VLAN priority bits can be used for QoS enforcement.

Stateful Firewall inspection of traffic is accomplished through the creation of Access Control Lists (ACLs) that enable the filtering of traffic based on numerous criteria including source and destination IP address, port and protocol.

Logical and physical ports are selectable for bridging or routing. Advanced IP features such NAT/NAPT and VLANs are likewise configurable on a per port basis. Bridged traffic can be tagged and prioritized according to user defined parameters.

The OS3300 offers easy installation, CLI configuration via Console/VT-100 or Telnet/SSH, and HTTP web based management, and SNMP. Patton's series of high-speed access IADs offer the versatility and reliability demanded for business-class applications at the most affordable price.

	TCPAM16/32	TCPAM64	TCPAM128
OS3301: 1 Pair (2-wire)	5.7 Mbps	11.4 Mbps	15.3 Mbps
OS3302: 2 Pair (4-wire)	11.04 Mbps	22.8 Mbps	30.6 Mbps
OS3304: 3 Pair (6-wire)	17.1 Mbps	34.2 Mbps	45.9 Mbps
OS3304: 4 Pair (8-wire)	22.8 Mbps	45.6 Mbps	61.2 Mbps

FEATURES & BENEFITS

- ✓ **Bandwidth Rich**—Bond up to 4 twisted pairs to achieve the desired rate and reach:
- ✓ **Operates Over Twisted Pair or Cat5+**—Near fiber speeds without the cost of new cable or fiber installations or the hassles of wireless line of site.
- ✓ **Connects Point-to-Point or to-DSLAM**—The OS3304 can be used either back to back or with any G.BIS compliant 3rd party or Patton DSLAM.
- ✓ **Auto Rate Adaptation Supported**—Will automatically select the best rate vs reach combination available based on a per wire basis.
- ✓ **Stateful Firewall Inspection**—Stateful firewall inspection is accomplished through ACLs that filter by source and destination IP address, IP port and protocol.
- ✓ **VLAN Tagging**—VLAN tagging and processing is configurable on Ethernet port.

More Patton EFM Solutions



ForeFront 3310P EFM Concentrator
24-Port G.SHDSL.bis DSLAM



OnSite 3088A/I EFM Bridge
G.SHDSL.bis EFM CPE



SmartNode 5300 EFM VoIP CPE
4 to 60 SIP Sessions eSBC

ORDERING INFORMATION

Obtain ordering info for this product by using the QR code at right or by contacting:

- email: sales@patton.com
- tel: +1 301.975.1000
- web: http://www.patton.com/products/product_detail.asp?id=494&tab=Ordering



Applications

The EFM bonding over copper wires provides the ability for transmitting high bandwidth data through multiple pairs over existing copper lines. EFM is an effective replacement for E1/T1 and a solid alternative solution to costly fiber. For long reach service, the G.SHDSL.bis enables the delivery of symmetrical high speed rates of 5.7 Mbps per pair.

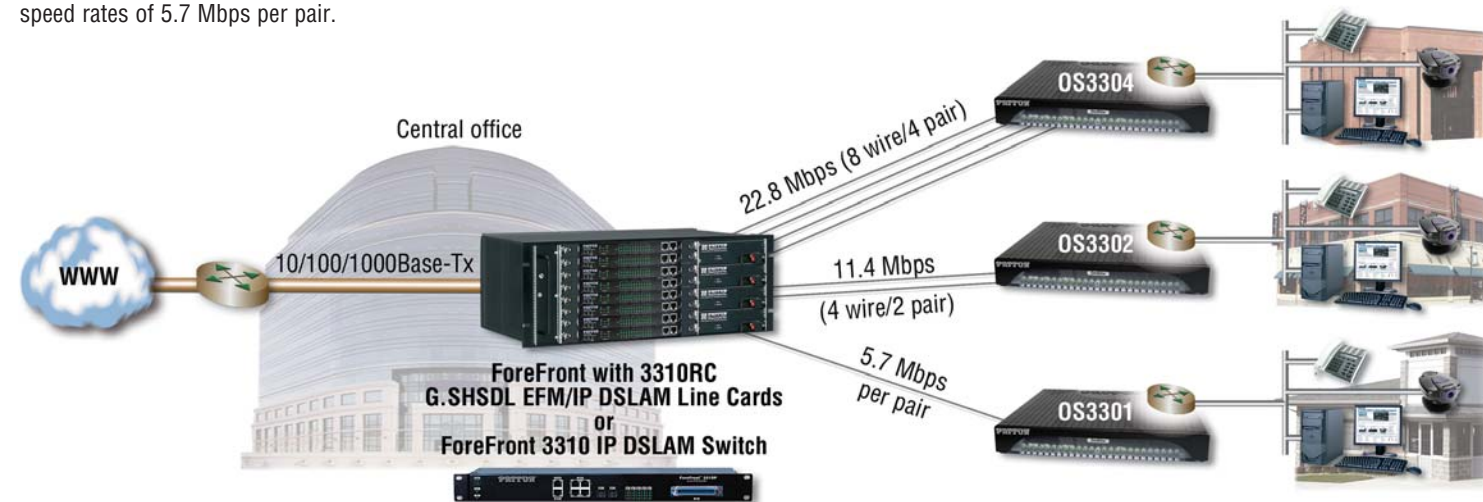

Extension and TCP to UDP conversion enables non-Lync-certified devices to operate with Lync

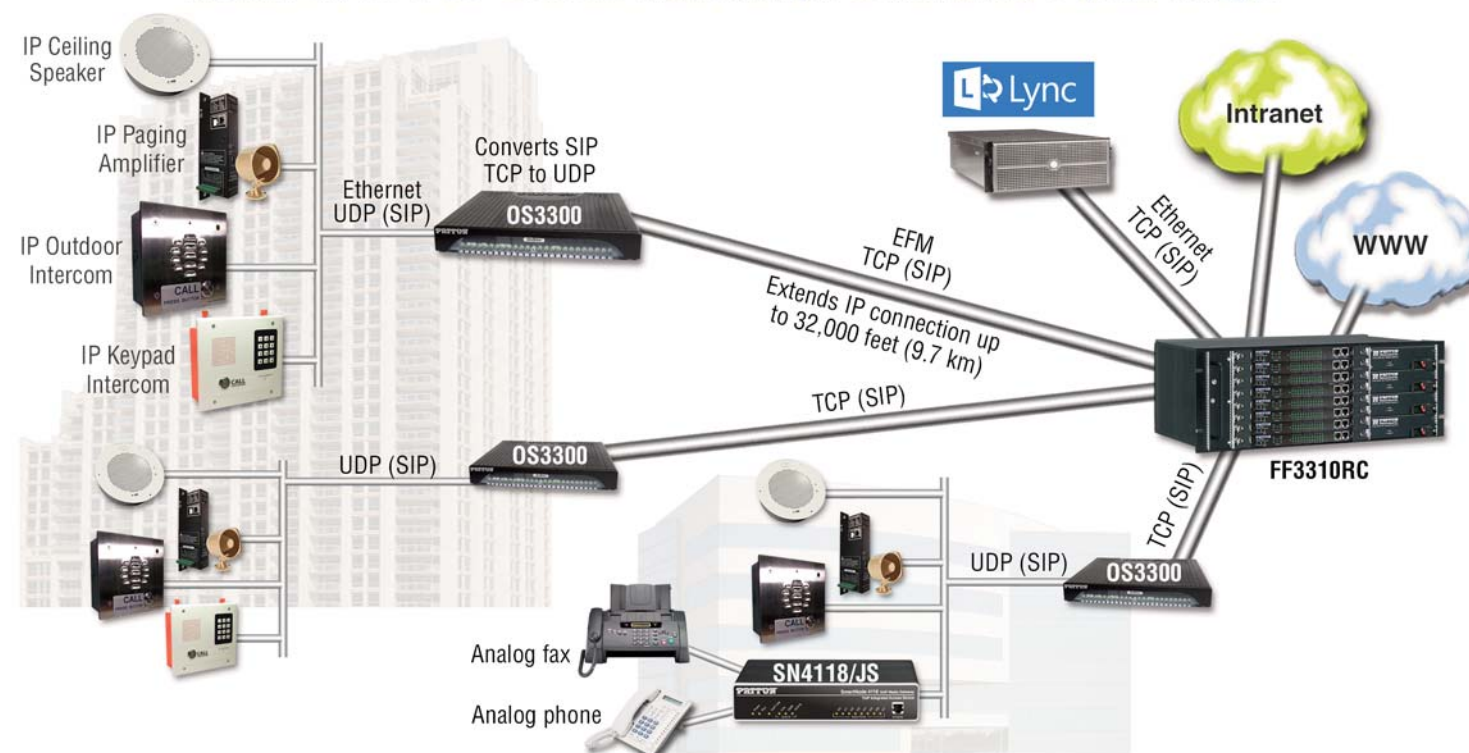



G.SHDSL High-Speed Routers

OnSite™ 3201 & 3241

Combine ITU/ETSI standards-based transmission with high speed networking, and deliver broadband IP access with the Model 3201 & 3241 G.SHDSL Routers.

Alternate product description:

- G.SHDSL Frame Relay, HDLC, ATM Router

Combining standards-based ITU/ETSI G.SHDSL transmission with high speed IP routing, the Model 3201 or 3241 is perfect for bandwidth intensive applications such as LAN-to-LAN networking, multimedia services, and e-commerce transactions.

Based on the International Telecommunications Union (ITU) and European Telecommunications Standardization Institute (ETSI) G.SHDSL G.991.2 standard, the Patton 3201 router enables providers to extend their reach-and-range by delivering rate-adaptive nx64 symmetrical speeds from 192 kbps to 2.3 Mbps—all over a single pair of wires. The Model 3241 delivers speeds up to 4.6 Mbps.

The routers offer easy installation and turn-up. With G.SHDSL support for auto-line configuration and ATM, PPP, or Frame Relay, the routers offer simple interfacing to any network. Standard IP feature set provides bridging and routing functionality along with advanced IP features like NAT and Firewall, and optional IPsec-based VPN. Get point-and-click control with the routers' built in HTTP/SNMP management interfaces.

As part of Patton's family of ipDSL products, the Models 3201 and 3241 offer complete, managed, end-to-end system when used with Patton's central site ipDSLAM equipment. With these features the Model 3201 or Model 3241 offer the clear and easy choice for mission-critical networking.

Applications

The 3201 and 3241 G.SHDSL routers offer standards-based DSL that supports the fundamental and advanced access requirements needed in the market today:

- Provide a routed packet-based CPE with IP centric services and functionality.
- Support compatibility with the ability to connect to standard DSLAMs using G.SHDSL.
- Utilize the preferred management method for ISP/CLEC/Carrier environments with the ability to manage devices from any workstation or PC across the Internet.



FEATURES & BENEFITS

- ✓ **G.SHDSL speeds to 2.3/4.6 Mbps**—Get broadband single-pair connectivity with TCPAM full-duplex symmetric rates and distances exceeding 30,000 feet (9.4 km)
- ✓ **ATM, PPP, and Frame Relay**—Versatile interface options enable simple deployment into any network
- ✓ **NAT/NAPT, Firewall, DHCP**—Powerful routing features make shared Internet connectivity simple and secure
- ✓ **Interoperable with DSLAMs**—Take advantage of Patton reliability whether you connect back-to-back or to a third-party DSLAM.
- ✓ **10/100 Ethernet with MDI-X**—Easily connect to any computer or LAN—the built-in crossover switch eliminates messy configuration cables
- ✓ **WWW/SNMP Manageable**—Built-in VT-100 console port makes setup a snap, and you can use the embedded HTTP/SNMP agent to manage the router from anywhere in the world.

ORDERING INFORMATION

Obtain ordering info for this product by using the QR code at right or by contacting:

- email: sales@patton.com
- tel: **+1 301.975.1000**
- web: http://www.patton.com/products/product_detail.asp?id=64&tab=Ordering



Frame Relay encapsulation over DSL for Ethernet traffic is supported with the purchase of a separate license key.



G.SHDSL CPE

OnSite™ 3088A

The Model 3088A is a low cost, manageable and software upgradeable G.SHDSL.bis CPE designed for service providers needing transparent last-mile telecom and data service delivery.

Alternate product description:

- G.SHDSL.bis TDM Modem

Patton's Model 3088A G.SHDSL.bis OnSite CPE is the perfect choice for users or service providers who need high-speed dedicated network connections. Based on the ITU and ETSI G.Shdsl G.991.2 standard, the 3088A enables providers to extend their reach-and-range by delivering rate-adaptive nx64 symmetrical speeds up to 5.7 Mbps—all over a single pair of wires.

The OnSite 3088A uses Patton's Plug 'n' Play features to remove any CPE configuration issues when used with any Patton CO concentration solution, even another 3088A CPE. Just set the units to their default mode and plug them in. The remote modem configures automatically and the link is up and running in seconds. With support for remote console link configuration changes and operating statistics are available via the out-of-band EOC channel. Remote and local loopback adds to the manageability of the link. Use remote console when deploying OnSite CPEs either back-to-back or with a ForeFront system to improve the manageability of the CPE.

The Model 3088A is available with V.35, X.21, and E1. The V.35 interface is presented on a female DB-25 connector. The X.21 is presented on a female DB-15 and is DTE/DCE selectable. The E1 interface is presented on an RJ-48C and dual BNC connector. It operates as a channelized interface allowing for fractional E1 configurations (G.703/G.704).

Applications

- The Model 3088A OnSite CPE excels in manageability even in point-to-point configurations.
- Plug 'n' Play automatically configures a remote unit based on parameters stored in the local unit.
- Secure console lets an operator log into a unit to manage and configure it locally.
- Remote console makes configuration and management of a remote unit easy over an out-of-band channel.
- OnSite CPEs are software upgradeable from the console port.
- When attached to a ForeFront AIS, the 3088A can be managed via an SNMP proxy.

Extension & Conversion



Access Concentration

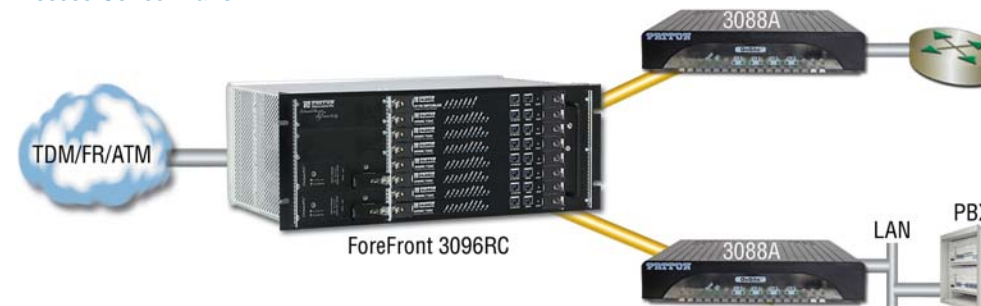

FEATURES & BENEFITS

- ✓ **nx64 Rates to 5.7 Mbps**—With multiple full-duplex symmetric rates available, users select the bandwidth option they need.
- ✓ **Low Cost Fixed Interfaces**—Multiple interface options to choose from: E1 (G.703/G.704), X.21, and V.35
- ✓ **Local and Remote Loopbacks**—Loopbacks add a powerful troubleshooting tool for determining line quality
- ✓ **Software Upgradeable**—Software upgrades make it easy to keep the OnSite CPE in service for years
- ✓ **Plug 'n' Play**—Just plug them in and the link comes up in seconds. Set the unit to use G.Handshaking and the selection of optimal link speeds can also be done automatically.
- ✓ **Local and Remote Console**—With remote console, any Patton G.SHDSL modem can be used to manage the remote CPE modem

ORDERING INFORMATION

Obtain ordering info for this product by using the QR code at right or by contacting:

- email: sales@patton.com
- tel: **+1 301.975.1000**
- web: http://www.patton.com/products/product_detail.asp?id=456





**G.SHDSL.bis EFM CPE
OnSite™ 2300**

The Model 2300 is a low cost, manageable and software upgradeable G.SHDSL.bis CPE designed for service providers needing transparent last-mile telecom and data service delivery.

Alternate product description:

- G.SHDSL.bis EFM/ATM Bridge

Patton's Model OnSite 2300 G.SHDSL.bis EFM CPE is the perfect choice for users or service providers who need high-speed dedicated network connections. Based on the ITU and ETSI G.Shdsl G.991.2 standard, the OS2300 enables providers to extend their reach-and-range by delivering rate-adaptive nx64 symmetrical speeds up to 15.3 Mbps—all over a single pair of wires. The OS2300 also supports 2 pair bonding enabling up to 30 Mbps over two twisted pairs. The OnSite 2300 can be deployed in point-to-point applications (single modem to single modem) or it can be used as an EFM CPE in conjunction with Patton's EFM DSLAM or other 3rd party EFM DSLAMs.

The OS2300 includes a 4 port Ethernet switch that can act as either an unmanaged or managed switch. The OS2300 offers easy installation, CLI configuration via Console/VT-100 or Telnet/SSH, HTTP web based management, and SNMP. Users can also select the OS2300 to be managed via DIP switch. By choosing the DIP switch option, technicians or installers can access and configure the OS2300 on-site without the use of a PC or laptop.

Patton's OnSite customer premise equipment offers the versatility and reliability demanded for business-class applications at the most affordable price.

Applications

Whether used as an Enterprise Session Border Controller or IP router, the SmartNode 5500 provides excellent VoIP, IP QoS, and security features for seamless network integration.

Thanks to the built-in SIP back-to-back user agent, it resolves technology evolution related problems by normalizing SIP traffic from different vendor implementations. In addition, enhanced security is given to the enterprise thanks to various features protecting the LAN infrastructure. Number manipulation and call routing options come standard with every Patton eSBC.

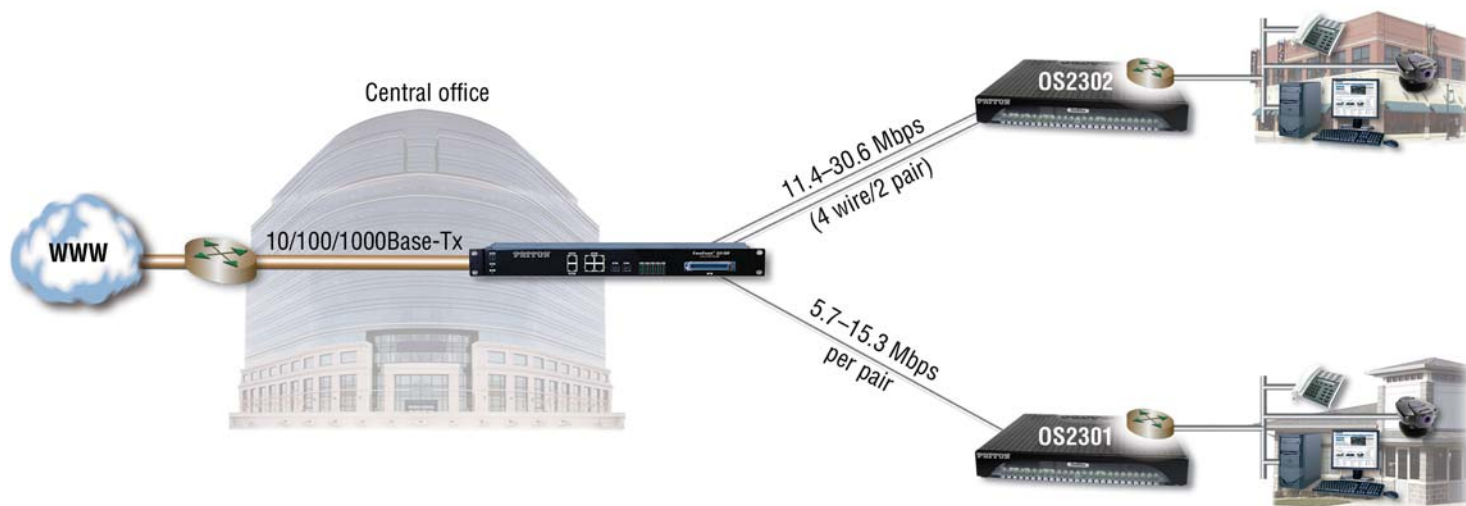

FEATURES & BENEFITS

- ✓ **nx64 Rates to 5.7 Mbps**—With multiple full-duplex symmetric rates available, users select the bandwidth option they need.
- ✓ **Low Cost Fixed Interfaces**—Multiple interface options to choose from: E1 (G.703/G.704), X.21, and V.35
- ✓ **Local and Remote Loopbacks**—Loopbacks add a powerful troubleshooting tool for determining line quality
- ✓ **Software Upgradeable**—Software upgrades make it easy to keep the OnSite CPE in service for years
- ✓ **Plug 'n' Play**—Just plug them in and the link comes up in seconds. Set the unit to use G.Handshaking and the selection of optimal link speeds can also be done automatically.
- ✓ **Local and Remote Console**—With remote console, any Patton G.SHDSL modem can be used to manage the remote CPE modem



**VDSL2/ADSL2+ Router
OnSite™ 2201**

The OnSite 2201 offers premium performance in a small package. This cost-effective VDSL2/ADSL2 router provides the bandwidth needed for today's bandwidth hungry, all-IP connected world.

Alternate product description:

- VDSL2/ADSL2+ Router

Patton's VDSL2 solutions allow service providers and enterprises to leverage their existing twisted pair for enabling the next generation high speed services and applications. Providing speeds of over 100 Mbps, VDSL2 is the perfect technology for the delivery of high quality triple-play services (IPTV, VoIP, WWW) or for providing high speed data backhaul throughout a campus.

The OS2201 is a small but feature-rich single-port bridge/router that is used for accessing the Internet or private network via a VDSL2/ADSL2+ connection. This connection is delivered by your service provider or, in campus or Multi-Tenant Unit applications, your privately owned DSLAM.

The OS2201 is fully compliant with VDSL2 standards—including G.Vector—and supports VDSL2 profiles from 8a to 30a. Because we are standards based, you can count on reliably connecting to Patton's VDSL2 DSLAM or to a third-party device or service.

This modem may be small, but it packs a punch when it comes to features. The OS2201 supports bridging, static and dynamic routing, IPv4/IPv6, ACLs, TR-069 and a host of firewall/security features that help ensure a safer and more secure Internet experience.

FEATURES & BENEFITS

- ✓ **Supports 100-Mbps Asymmetrical Line Rate**—Provides near fiber performance for bandwidth intensive applications.
- ✓ **Operates Over Twisted Pair**—Reduces the cost and hassles of new installations. Uses installed voice-grade twisted pairs to eliminate the expense of installing network or fiber cable.
- ✓ **Flexible Deployment**—Supports full ADSL2/ADSL2+ or ADSL+ fallback.
- ✓ **Firewall**—Surf the Internet safely and securely.
- ✓ **Full VDSL2 Profile Support**—Support for 8a, 8b,8c, 8d, 12a, 12b, 17a, and 30a.
- ✓ **TR-069 Compliant**—Eases management and can reduce hotline costs significantly.

Typical Application

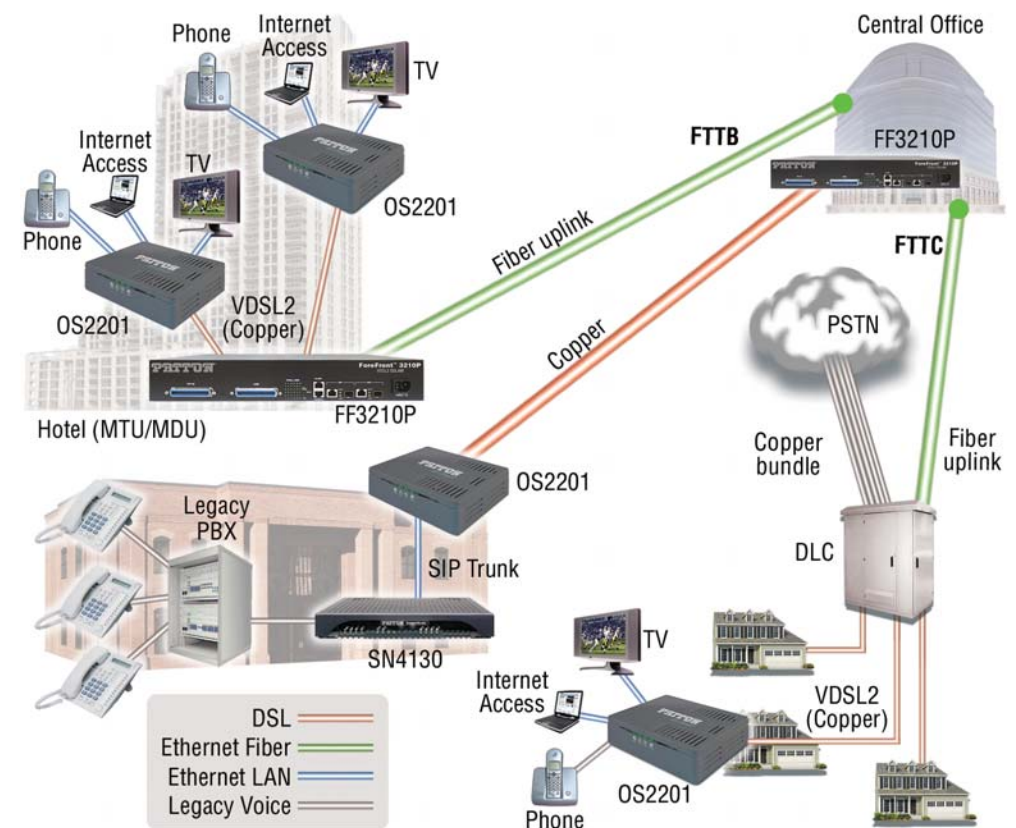

Patton VDSL2 Products



**ForeFront Model 3210P
24-Port VDSL2 DSLAM**



**OnSite Model 1069DV
VDSL2 Point-to-Point Bridges
Optional Built-in POTS/ISDN Splitters**



VDSL2 100-Mbps Bridge
OnSite™ 1069

Patton's 1069 VDSL2 Ethernet Bridge offers the extraordinary bandwidth of 100-Mbps symmetrical over ordinary telephone grade copper wire for delivering next-generation Triple Play services. For higher density applications the 1069 can be used with Patton's 24 port VDSL2 DSLAM, the FF3210P.

Alternate product descriptions:

- VDSL2 100-Mbps Bridge

Patton's Model 1069 VDSL2 Bridge leverage existing copper infrastructure, providing up to 100 Mbps symmetrical links over telephone grade

twisted pair. Providing up to 100 Mbps of symmetrical data makes the Patton Model 1069 the perfect solution for delivering Triple Play communications services and other bandwidth-intensive applications.

The Model 1069 is fully compliant with the VDSL2 standards ITU-T G.993.1, G.993.2, ANSI T1.424 and ETSI TS 101 270-1, 270-2. Support for all VDSL2 profiles including 8a, 8b,8c, 8d, 12a, 12b, 17a, and 30a make the Model 1069 the ideal VDSL2 CPE for various MxU and FTTx type installations. An on-board POTS splitter allowing users to download files from the Internet, surf the WWW, and answer e-mail messages while talking on the phone or faxing documents.

Configuration is a snap when used together with Patton's VDSL2 DSLAM, the ForeFront Model 3210P. Through the use of OAM (Object Access Method), the Model 1069 is fully configurable via the DSLAM. The CPE will auto rate adapt to the highest available bandwidth allowable by the FF3210P. The Model 1069 is also fully compatible with any third-party VDSL2 compliant DSLAM.

Typical Application

Using Patton's FF3210P or any third-party DSLAM, full-service high speed links can be routed through campus and various MxU environments. VDSL2 DSLAMs aggregate the IP services delivered from the ISP or service providers with the POTS delivered from the PSTN. The POTS and Ethernet signals are then aggregated and sent over an existing 2-wire telephony grade connection. The Model 1069 VDSL2 CPE is placed in each room to split the signal back into Ethernet (data) and POTS/ISDN (voice) for delivery to the end-user. Port selectable data rates allow for a differentiation of services, and increased distance capabilities.

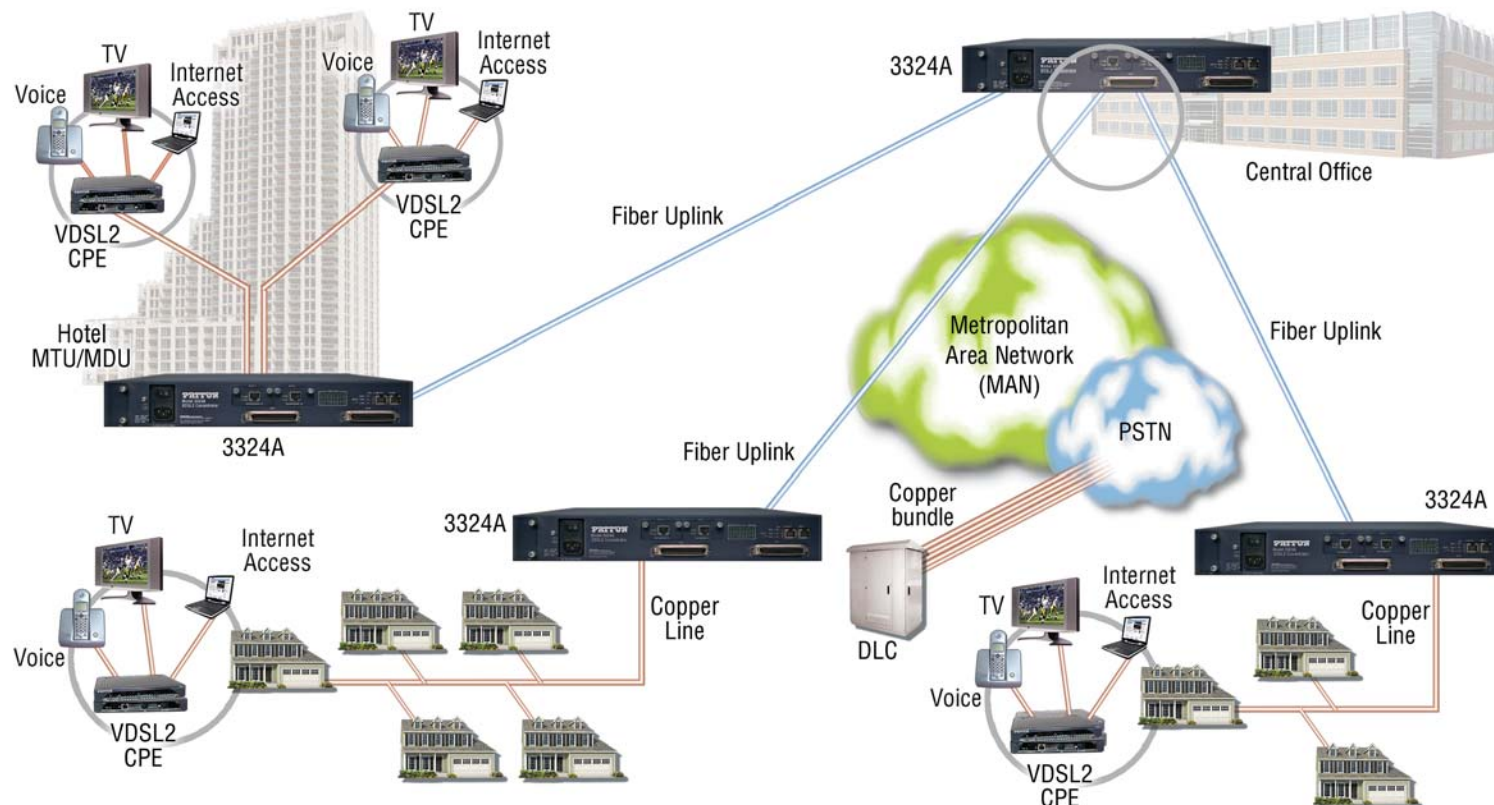

FEATURES & BENEFITS

- ✓ **Support of 100-Mbps Symmetrical Line Rate**—Provides near fiber performance for bandwidth intensive applications such as Triple Play services.
- ✓ **Operates Over Twisted Pair**—Reduces the cost and hassles of new installations. Uses installed voice-grade twisted pairs to eliminate the expense of installing network or fiber cable.
- ✓ **Flexible Configurations**—Can operate either point to point (configurable as CO/CP), with Patton's 24 port VDSL2 DSLAM FF3210P or any third-party VDSL2 compliant DSLAM.
- ✓ **Full VDSL2 Profile Support**—Support for 8a, 8b,8c, 8d, 12a, 12b, 17a, and 30a. Band plans 997 & 998.
- ✓ **On-board POTS/ISDN Splitter**—Reliably connect to POTS/ISDN services. Allows for smooth transition from traditional telephony to VoIP.

ORDERING INFORMATION

Obtain ordering info for this product by using the QR code at right or by contacting:

- email: sales@patton.com
- tel: **+1 301.975.1000**
- web: http://www.patton.com/products/product_detail.asp?id=461&tab=Ordering



Ethernet-over-Fiber SFP Module
SFP1G10

1 Gbps SFP optical transceiver, single-mode/10 km, 1310 nm

Fiber Mode	Single-mode
Typical Distance	10 km
Operating Temperature	0~70°C
Wavelength	1310 nm
Optical Output Power 9/125 μm fiber (Max. TX)	-3 dBm
Optical Output Power 9/125 μm fiber (Min. TX)	-9.5 dBm
Optical Input Power minimum (Sensitivity)	-20 dBm
Optical Input Power maximum	-3 dBm
Link Budget	10.5 dB



Ethernet-over-Fiber SFP Module
SFP1G20

1 Gbps SFP optical transceiver, single-mode/20 km, 1310 nm

Fiber Mode	Single-mode
Typical Distance	20 km
Operating Temperature	0~70°C
Wavelength	1310 nm
Optical Output Power 9/125 μm fiber (Max. TX)	-2 dBm
Optical Output Power 9/125 μm fiber (Min. TX)	-8 dBm
Optical Input Power minimum (Sensitivity)	-23 dBm
Optical Input Power maximum	-3 dBm
Link Budget	15 dB



Ethernet-over-Fiber SFP Module
SFP1G20B3

1 Gbps SFP optical transceiver, single-mode BIDI/20 km, transmit 1310 nm, receive 1550 nm

Fiber Mode	Single-mode
Typical Distance	20 km
Operating Temperature	0~70°C
Wavelength	Transmit: 1310 nm Receive: 1550 nm
Optical Output Power 9/125 μm fiber (Max. TX)	-2 dBm
Optical Output Power 9/125 μm fiber (Min. TX)	-8 dBm
Optical Input Power minimum (Sensitivity)	-23 dBm
Optical Input Power maximum (Saturation)	-1 dBm
Link Budget	15 dB



Ethernet-over-Fiber SFP Module
SFP1G20B5

1 Gbps SFP optical transceiver, single-mode BIDI/20 km, transmit 1550 nm, receive 1310 nm

Fiber Mode	Single-mode
Typical Distance	20 km
Operating Temperature	0~70°C
Wavelength	Transmit: 1550 nm Receive: 1310 nm
Optical Output Power 9/125 μm fiber (Max. TX)	-2 dBm
Optical Output Power 9/125 μm fiber (Min. TX)	-8 dBm
Optical Input Power minimum (Sensitivity)	-23 dBm
Optical Input Power maximum (Saturation)	-1 dBm
Link Budget	15 dB

The SFP Modules are available for ordering as accessories for Patton optical fiber capable SmartNode devices.

For other SFP options, contact sales@patton.com.

www.patton.com

Patton Electronics Co.
7622 Rickenbacker Drive
Gaithersburg, Maryland 20879
USA
Phone +1 301 975 1000
Fax +1 301 869 9293
E-mail sales@patton.com

Patton-Inalp Networks AG
Meriedweg 7
CH-3172 Niederwangen
Switzerland
Phone +41 (31) 985 25 25
Fax +41 (31) 985 25 26
E-mail we@patton.com

Patton Hungary Zrt
Gábor Dénes utca 4.
Infopark Building C, Budapest H-1117
Hungary
Phone +36 1 439 4840
Fax +36 1 439 4844
E-mail ce@patton.com



PATTON[®]
Let's Connect![™]