

Quick Guide

1. Before Installing

Congratulations on purchasing your **AudioCodes 420HD IP Phone**! Before you begin using the phone, make sure that the following items are included in the shipped box:

- ✓ 420HD IP Phone
- ✓ AC power adapter (optional)
- ✓ Cat 5e Ethernet cable
- ✓ Phone base stand
- ✓ Handset
- ✓ Handset cord
- ✓ Wall-mounting screws

2. Physical Description



3. Cabling the Phone



Warning: Prior to connecting power, refer to the *Compliance and Regulatory Information* document at www.audiocodes.com/library.

To cable the phone:

1. Connect the short, straight end of the phone cord to the handset and the longer straight end of the cord to the handset jack on the phone.
2. (Optional) Connect the RJ-9 headset jack to a headset.
3. Connect the RJ-45 LAN port to your LAN network (LAN port or LAN switch/router) with a CAT 5 / 5e Ethernet cable.
4. Connect the RJ-45 PC port to a computer with a CAT 5 / 5e straight-through Ethernet cable.
5. Connect the connector tip of the AC power adapter to the phone's DC 12V power socket and connect the two-prong AC adapter directly to the electrical wall outlet. When the phone powers up, all the LEDs momentarily light up.

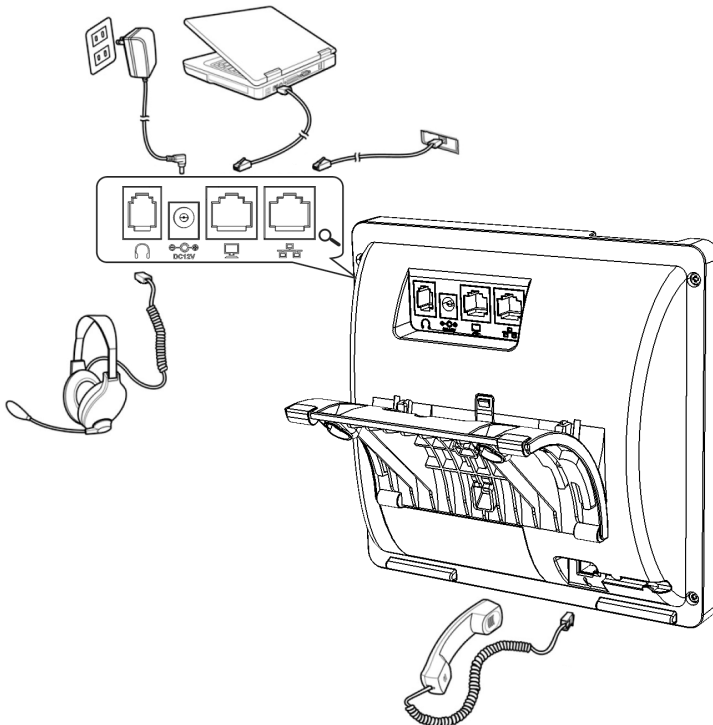

4. Attaching Phone Base Stand to Phone Unit

For instructions on assembling the base stand, scan me or visit

<https://www.youtube.com/watch?v=oGe9STB9IFE>

- ✓ **Desktop mounting:** Slide outer rails (A) of phone stand onto outer notches (A).
- ✓ **Wall mounting:** Slide middle rails (B) of phone stand onto inner notches (B).

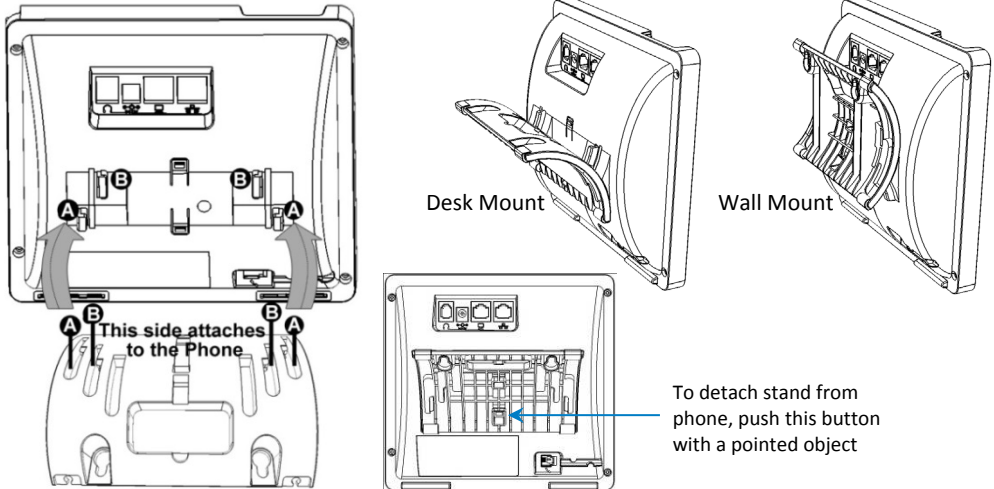

5. Upgrading IP Phone Firmware for Microsoft Lync Server 2010

If you need to upgrade your phone's firmware for Lync, refer to the *Software Upgrade Configuration Note*, downloadable from <http://www.audiocodes.com/downloads>.

6. Signing in to Lync

☞ To sign in with Microsoft Lync client, see the *Microsoft Lync BToE Configuration Note*.

☞ To sign in with your PIN:

1. Press the **Sign in** softkey (when the LCD is in idle mode).
2. Scroll down and select **Switch sign-in method**.
3. Enter your phone number and PIN number, and press **Sign in**.

☞ To sign in with your username and password (default method):

1. Press the **Sign in** softkey (when the LCD is in idle mode).
2. Enter your sign-in address (SIP address). Press the phone's **1** key to enter a period/fullstop. To enter @ or -, repeat-press it until @ or - is displayed. Press **Clear** to edit. Press the control to scroll across.
3. Scroll down and enter your domain\username, e.g., company\mike. Repeat-press the phone's # key to select abc, ABC, Abc, or 123. Repeat-press the phone's **1** key until \.
4. Scroll down and enter your user password – the same you use for PC access – and then press **Sign in**.

☞ To sign out: Press the **Status** softkey when the LCD is in idle mode, and then press **Sign out**.



Sign in Softkey

7. Changing your Lync Presence Status

- ☛ **To change your presence:** Press the **Status** softkey (when LCD is in idle mode), scroll down to the required presence, and then press the **Select** softkey.
- ☛ **To have Lync Server automatically update your presence:** Press **Status** softkey (when LCD is in idle mode) and select **Reset**.



8. Basic Phone Operation

- ☛ **To make a call:** Pick up the handset, enter a phone number and then press the **Dial** softkey. To call a phone contact, press the directory icon softkey, select the contact and then press the **Dial** softkey.
- ☛ **To redial a number:** Press the REDIAL key, select a dialed number, and then press the **Dial** softkey.
- ☛ **To answer a call:** Pick up the handset, or press the speaker or headset key.
- ☛ **To place a call on hold and make another call:** Press the **New Call** softkey, enter a phone number and press the **Dial** softkey. To return to the held call, press the down key and press the **Resume** softkey.
- ☛ **To mute a call:** Press the mute key. To resume the conversation, press the mute key again.
- ☛ **To transfer a call:** During a call, press the **≡** softkey, navigate to **Trans** or **Blind transfer**, enter the phone number to transfer the call to, and then press the **Dial** or **Trans** softkey.
- ☛ **To forward incoming calls to another phone:**
 1. Press the **Forward** softkey (when LCD is in idle mode), scroll down and select **Forward to a Number**.
 2. Enter the number to where you want to forward calls, and then press the **Start** softkey. To deactivate call forwarding, press the **Forward** softkey and then select **Do not forward calls**.

Notice Information

This Quick Guide describes the quick setup for AudioCodes 420HD IP Phone Version 2.0.x. If you have a later version, verify with AudioCodes that the information in this document is compatible with your IP Phone.

Information contained in this document is believed to be accurate and reliable at the time of printing. However, due to ongoing product improvements and revisions, AudioCodes cannot guarantee accuracy of printed material after the Date Published nor can it accept responsibility for errors or omissions. Updates to this document and other documents as well as software updates can be viewed by registered customers on AudioCodes' Web site at www.audiocodes.com/downloads.

© Copyright 2015 AudioCodes Ltd. All rights reserved.

This document is subject to change without notice.

Date Published: June-01-2015

Document #: LTRT-11844

International Headquarters

1 Hayarden Street, Airport City, Lod 7019900

P.O. Box 255, Ben Gurion Airport, Israel, 7019900

Tel: +972-3-976-4000 Fax: +972-3-976-4040

